

Article

Not peer-reviewed version

Inactivation of Bacterial and Viral Bioaerosols by Lactoferrin-Coated Filters under Various Environmental Conditions

[Shinhao Yang](#)^{*}, Hsiao-Chien Huang, [Ying-Fang Hsu](#), [Chi-Yu Chuang](#)

Posted Date: 9 February 2026

doi: 10.20944/preprints202602.0533.v2

Keywords: bioaerosols; lactoferrin; occupational hygiene; engineering control; indoor air quality; secondary aerosolization



Preprints.org is a free multidisciplinary platform providing preprint service that is dedicated to making early versions of research outputs permanently available and citable. Preprints posted at Preprints.org appear in Web of Science, Crossref, Google Scholar, Scilit, Europe PMC.

Copyright: This open access article is published under a [Creative Commons CC BY 4.0 license](#), which permit the free download, distribution, and reuse, provided that the author and preprint are cited in any reuse.

Disclaimer/Publisher's Note: The statements, opinions, and data contained in all publications are solely those of the individual author(s) and contributor(s) and not of MDPI and/or the editor(s). MDPI and/or the editor(s) disclaim responsibility for any injury to people or property resulting from any ideas, methods, instructions, or products referred to in the content.

Article

Inactivation of Bacterial and Viral Bioaerosols by Lactoferrin-Coated Filters under Various Environmental Conditions

Shin hao Yang ^{1,*}, Hsiao-Chien Huang ¹, Ying-Fang Hsu ¹ and Chi-Yu Chuang ²

¹ Environmental Sustainability Lab, Natural Science, Center for General Education, CTBC Business School, No. 600, Section 3, Taijiang Boulevard, Annan District, Tainan City 709, Taiwan

² Department of Occupational Safety and Health, Chang Jung Christian University, No.1, Changda Road, Gueiren District, Tainan City 711, Taiwan

* Correspondence: shinhaoyang@ntu.edu.tw; Tel.: +886-6-287-3198

Abstract

Accumulation of viable bioaerosols on air filters poses significant occupational health risks, particularly regarding secondary aerosolization during maintenance in high-density indoor environments. To address this challenge, this study developed a bovine lactoferrin-functionalized polypropylene (LfCF) filter as an active engineering control intervention. The filtration performance was evaluated against *E. coli* and λ phage virus under varying environmental conditions. Results demonstrated broad-spectrum inactivation efficacy, with the 2.0 mg coating achieving optimal performance in a dose-dependent manner. Crucially, the lactoferrin coating exhibited superior environmental stability; unlike traditional biopolymers (e.g., chitosan), its antimicrobial efficiency remained consistent across 30–70% relative humidity (RH), ensuring reliability in damp HVAC systems. To validate realistic use scenarios, a field test was conducted in a dental clinic waiting area, achieving an ~83% reduction in airborne bacteria. This study positions LfCFs as a robust, “Safe-by-Design” solution for mitigating bioaerosol exposure and enhancing occupational safety in healthcare and public facilities.

Keywords: bioaerosols; lactoferrin; occupational hygiene; engineering control; indoor air quality; secondary aerosolization

1. Introduction

Bioaerosols, comprising airborne bacteria, viruses, fungi, and their by-products, are ubiquitous in indoor environments [1]. While often harmless in low concentrations, their accumulation in high-density occupational settings—such as healthcare facilities, dental clinics, and waste management centers—poses significant health risks. According to the World Health Organization (WHO) guidelines, exposure to these biological agents is a primary cause of infectious diseases and toxic allergic reactions among workers [2]. In the framework of occupational hygiene, the NIOSH Hierarchy of Controls prioritizes engineering controls (such as air filtration) over administrative measures or personal protective equipment (PPE) for reducing such exposures [3]. Consequently, developing effective air-cleaning technologies has become a critical focus in environmental hygiene to protect public health [4–8].

To mitigate these biological risks, various air-cleaning technologies have been developed. Active disinfection methods, which release biocidal agents into the air, have shown promising results. For instance, in our recent study, we demonstrated that membrane-less electrolyzed water (MLEW) spraying could effectively inactivate H6N1 avian influenza virus aerosols in simulated indoor environments [9]. Similarly, we evaluated the efficacy of a carbon-nanotube (CNT) coated plasma system, which achieved significant inactivation of bioaerosols through reactive species generation

[10]. However, from an occupational safety perspective, limitations exist. While such active systems are highly effective against airborne pathogens, they often require complex equipment, energy consumption, and precise control to prevent potential respiratory irritation from chemical residuals (e.g., chlorine or ozone), which constitutes an additional chemical hazard for occupants [9,11].

Consequently, passive control strategies, particularly antimicrobial filtration, remain the most practical and widely adopted solution for continuous air purification in heating, ventilation, and air conditioning (HVAC) systems. Traditional high-efficiency particulate air (HEPA) filters are proficient at physically capturing fine particles but lack intrinsic antimicrobial properties. Captured microorganisms can remain viable on the filter surface, proliferate under favorable temperature and humidity conditions, and potentially become secondary pollution sources [12,13]. This creates a specific occupational risk known as “re-aerosolization,” particularly threatening maintenance personnel during filter replacement or disposal [14]. This concern aligns with ASHRAE Standard 241, which calls for enhanced control of infectious aerosols beyond simple physical capture [15].

To address this, coating fibrous media with antimicrobial agents has become a major research focus. Inorganic agents like silver nanoparticles and photocatalytic titanium dioxide have been extensively studied [16,17]; however, concerns regarding their environmental toxicity and cost have shifted attention toward natural, biocompatible biopolymers [18]. In our previous work, we successfully developed a chitosan-coated air filter that demonstrated significant inactivation efficiency against bacterial bioaerosols [19]. Chitosan, a cationic polysaccharide, disrupts microbial cell walls via electrostatic interactions. However, a critical limitation observed in our previous study and others is that the antimicrobial performance of chitosan and similar cationic polymers is often sensitive to environmental relative humidity (RH) [19,20]. High humidity can alter the polymer’s charge density or structure, potentially compromising its efficacy.

Therefore, identifying a natural antimicrobial agent that maintains broad-spectrum efficacy and stability under varying environmental conditions remains a key challenge for practical applications. Lactoferrin (Lf), an iron-binding glycoprotein widely present in mammalian secretions (e.g., milk, saliva), emerges as a promising candidate due to its inherent stability and broad-spectrum activity [21–23]. Unlike synthetic biocides, Lf is non-toxic and biodegradable [24–27]. In this study, we developed a bovine lactoferrin-functionalized polypropylene (PP) filter and evaluated its performance against both bacterial and viral bioaerosols. Crucially, to address the need for realistic exposure control assessments, we conducted a field validation in a dental clinic waiting area—a representative high-risk occupational setting. This study aims to position lactoferrin-functionalized filters as a robust engineering control solution within the broader hygiene framework.

2. Materials and Methods

2.1. Preparation of Lactoferrin-Functionalized Filters

A commercial single-layer polypropylene (PP) nonwoven air filter was used as the substrate material (KNH Enterprise Co., Ltd., Tainan, Taiwan). Bovine lactoferrin peptide (Lactoferricin B) was selected as the antimicrobial agent due to its potent broad-spectrum activity. The specific peptide sequence used was KCRRWQWRMCKLGAPSITCV, which corresponds to the antimicrobial active center of bovine lactoferrin.

The coating solutions were prepared by dissolving the synthesized peptides into a binding buffer (50 mM Tris-Cl, pH 7.4, 5 mM KCl, 100 mM NaCl, and 1 mM MgCl₂). To investigate the dose-dependent efficacy, two distinct coating concentrations were prepared: 1.0 mg and 2.0 mg of lactoferrin peptide per 100 mL of buffer solution, respectively. To ensure the stability of the antimicrobial coating on the hydrophobic PP fibers, Poly(allylamine) (average Mw ~65,000, 20 wt%), diluted 10-fold with the binding buffer, was added as a cross-linking agent. The coating process involved immersing the PP filters in the prepared solutions and agitating at 50 rpm for 24 h at room temperature to ensure uniform binding. Subsequently, the lactoferrin-coated filters (LfCFs) were

dried at room temperature in a sterilized laminar flow hood. An untreated PP filter subjected to the same wetting and drying process (without lactoferrin) served as the control group.

2.2. Test Microorganisms

To evaluate the broad-spectrum antimicrobial efficiency of the functionalized filters, two representative bioaerosol surrogates were selected:

Bacterial Surrogate: *Escherichia coli* (*E. coli*, strain K12), a Gram-negative bacterium, was selected as the model organism for environmental bacterial pathogens. It was cultured in Tryptic Soy Broth (TSB) at 37°C for 18–24 h prior to aerosolization.

Viral Surrogate: Lambda virus (λ virus, NCCB 3467) was chosen as a surrogate for pathogenic viruses. The λ virus is a non-enveloped bacterial virus consisting of an isometric head (approximately 0.05 μm in diameter) and a long flexible tail (approximately 0.15 μm in length). It infects *E. coli* K12 host cells and is widely utilized as a model for water-borne and airborne viruses due to its structural stability and safety for laboratory handling.

2.3. Bioaerosol Generation and Experimental Setup

The experimental system for evaluating the filtration and inactivation efficiency is illustrated in Figure 1. The microbial suspension (either *E. coli* or λ virus) was aerosolized using a Collision three-jet nebulizer (BGI Inc., Waltham, MA, USA) operated at a pressure of 20 psig. The generated bioaerosol stream passed through a diffusion dryer to remove excess moisture and was subsequently neutralized to the Boltzmann equilibrium charge distribution using a Krypton-85 (Kr-85) radioactive neutralizer (Model 3077, TSI Inc., Shoreview, MN, USA). This step was crucial to minimize electrostatic losses during transport and to ensure that particle capture was primarily due to the filter mechanisms rather than incidental charge.

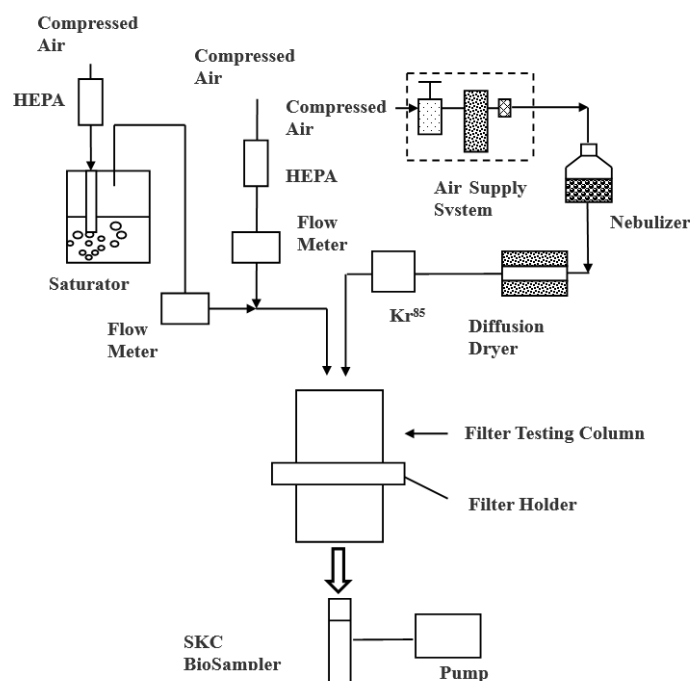

Figure 1. Schematic diagram of the experimental setup.

The neutralized bioaerosols were then introduced into a mixing chamber, where they were mixed with HEPA-filtered dilution air. The relative humidity (RH) of the airflow was precisely controlled at three levels (30%, 50%, and 70%) by adjusting the ratio of dry air to humidified air generated by a water vapor saturator. The RH and temperature were continuously monitored using

a hygrometer (Q-Trak Plus, Model 8552, TSI Inc., Shoreview, MN, USA). The test filter was mounted in a custom-made filter holder, and the face velocity was controlled at 10, 20, and 30 cm/s, respectively, to simulate different HVAC operating conditions.

2.4. Bioaerosol Sampling and Survival Analysis

To differentiate between physical removal and biological inactivation, bioaerosols passing through the filters were collected using a BioSampler (SKC Inc., Eighty Four, PA, USA), a liquid impinger designed to preserve microbial viability during high-efficiency collection. The sampling flow rate was maintained at 12.5 L/min for 10 minutes, with microorganisms collected into 20 mL of phosphate-buffered saline (PBS).

Bacterial Analysis: The collection liquid containing *E. coli* was serially diluted and plated on Tryptic Soy Agar (TSA). The plates were incubated at 37°C for 24 h, and colonies were counted to determine the colony-forming units (CFU).

Viral Analysis: The concentration of infectious λ virus was determined using the double-layer agar plaque assay method. The collected viral samples were mixed with *E. coli* host cells and soft agar, then poured onto solid agar plates. After incubation at 37°C for 16–24 h, the plaques were enumerated as Plaque Forming Units (PFU).

2.5. Data Analysis

The bioaerosol survival rate (S) was calculated to quantify the antimicrobial efficacy of the lactoferrin coating. It is defined as the ratio of viable counts downstream of the Lf-coated filter (C_{Lf}) to those downstream of the control filter ($C_{control}$), under identical experimental conditions:

$$S (\%) = (C_{Lf}/C_{control}) \times 100\%$$

Statistical analysis was performed to determine the significance of the effects of lactoferrin concentration, face velocity, and relative humidity on bioaerosol survival. A p-value of less than 0.05 was considered statistically significant.

3. Results

3.1. Inactivation Efficiency Against Bacterial Bioaerosols (*E. coli*)

The inactivation performance of the lactoferrin-functionalized filters against bacterial bioaerosols was evaluated by measuring the survival rates of *E. coli* under different coating concentrations and face velocities. Figure 2 illustrates the survival rates of *E. coli* passing through the control filter (uncoated) and filters coated with 1.0 mg and 2.0 mg of lactoferrin peptide per 100 mL, respectively.

The results clearly demonstrated that the lactoferrin coating possesses significant antibacterial activity, which acts in a dose-dependent manner. As shown in Figure 2, the survival rates of *E. coli* on the lactoferrin-coated filters were consistently lower than those on the control filter across all tested face velocities. At the lowest face velocity of 10 cm/s, the filter with the highest lactoferrin loading (2.0 mg) achieved the best performance, reducing the bacterial survival rate to approximately 41% ($p < 0.05$). Comparing this data with the control group, it implies that while physical filtration captured a portion of the bioaerosols, approximately 59% of the reduction in bacterial viability was specifically attributed to the biochemical inactivation effect of the lactoferrin coating. This calculation differentiates the net antimicrobial efficacy from the physical interception mechanisms inherent to the polypropylene fibers.

However, the inactivation efficiency was found to be negatively correlated with the face velocity. As the face velocity increased from 10 cm/s to 30 cm/s, the survival rate of *E. coli* on the 2.0 mg lactoferrin-coated filter increased from 41% to approximately 65%. This trend is consistent with our previous findings on chitosan-coated filters [19]. The reduced inactivation efficiency at higher filtration velocities can be attributed to the shorter residence time of the bioaerosols within the filter

media. A shorter contact duration limits the interaction time between the bacterial cell walls and the immobilized lactoferrin peptides, thereby reducing the proportion of inactivated bacteria.

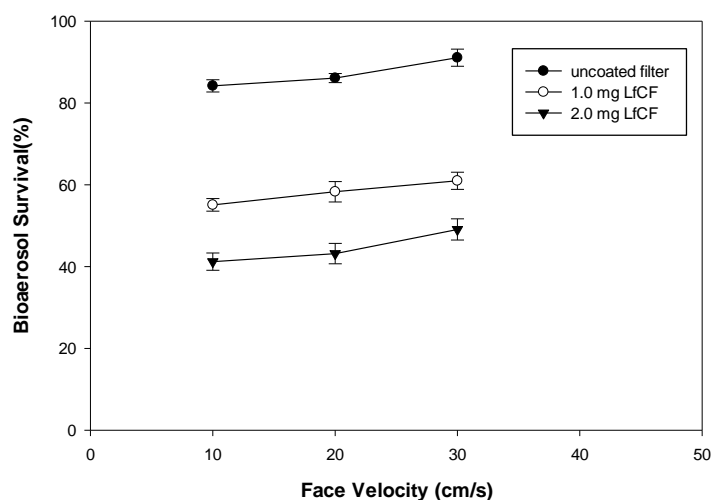

Figure 2. Survival rates of *E. coli* bioaerosols passing through the control and lactoferrin-coated filters (1.0 mg and 2.0 mg) under different face velocities (10, 20, and 30 cm/s).

3.2. Inactivation Efficiency Against Viral Bioaerosols (λ Virus)

In addition to bacterial testing, the broad-spectrum efficacy of the lactoferrin-functionalized filters was further evaluated using λ virus aerosols. Figure 3 presents the survival rates of λ virus passing through the control and treated filters under identical experimental conditions.

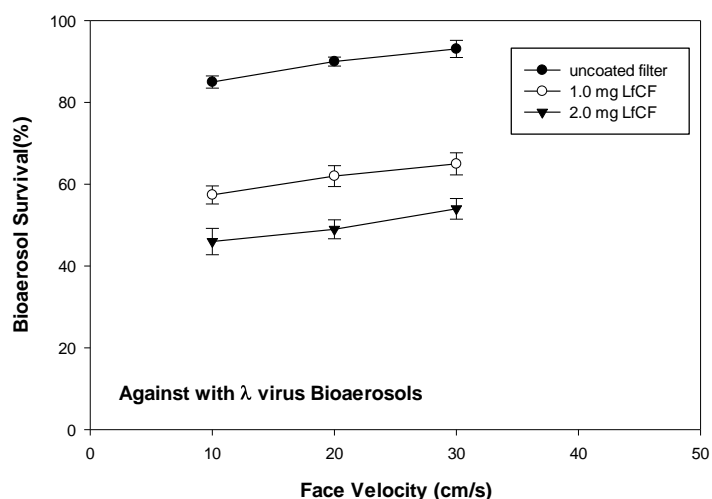

Figure 3. Survival rates of λ virus bioaerosols passing through the control and lactoferrin-coated filters (1.0 mg and 2.0 mg) under different face velocities (10, 20, and 30 cm/s).

The results exhibited a trend highly similar to that observed in the bacterial experiments, confirming that the antimicrobial activity of lactoferrin is not limited to bacteria but also extends to viral agents. At a face velocity of 10 cm/s, the filter coated with 2.0 mg of lactoferrin achieved a survival rate of approximately 46% ($p < 0.05$). Applying the same attribution analysis as in the bacterial trials, this result indicates that approximately 54% of the reduction in viral infectivity was specifically attributed to the biochemical inactivation mechanism of the lactoferrin coating, rather

than physical filtration alone. This antiviral capability is likely due to the interaction between the cationic lactoferrin peptides and the viral capsid proteins, which can disrupt the structural integrity of the virus or block its ability to infect the host cells.

Consistent with the bacterial results, the antiviral efficiency decreased as the face velocity increased. When the face velocity was raised to 30 cm/s, the survival rate of λ virus on the 2.0 mg coated filter increased to approximately 70%. This phenomenon further supports the “residence time” hypothesis, suggesting that sufficient contact time is a critical factor for the effective inactivation of viral bioaerosols by immobilized antimicrobial agents.

3.3. Environmental Stability: The Effect of Relative Humidity

One of the most critical challenges in applying natural biopolymers for air filtration is their sensitivity to environmental moisture. To evaluate the stability of the lactoferrin coating, we investigated the inactivation efficiency against both *E. coli* and λ virus under varying relative humidity (RH) levels (30%, 50%, and 70%) at a fixed face velocity of 10 cm/s. Figure 4 and Figure 5 summarize the survival rates of the tested bioaerosols on the 2.0 mg lactoferrin-coated filters under these conditions.

Remarkably, the results indicated that the antimicrobial performance of the lactoferrin-functionalized filters was independent of the environmental humidity. As shown in Figure 4, the survival rates for both *E. coli* and λ virus remained relatively constant across the tested RH range. Statistical analysis (ANOVA) confirmed that there was no significant difference ($p > 0.05$) in the inactivation efficiency among the 30%, 50%, and 70% RH groups.

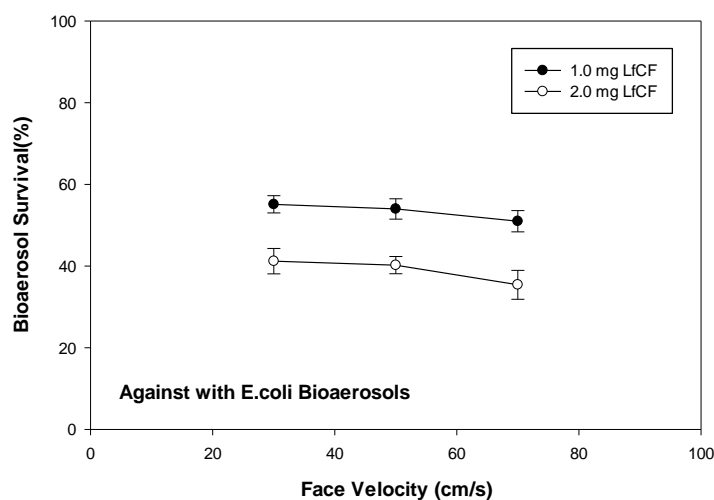

Figure 4. Effect of relative humidity (30%, 50%, and 70%) on the survival rates of *E. coli* bioaerosols collected from the lactoferrin-coated filters (2.0 mg) at a face velocity of 10 cm/s.

This finding stands in sharp contrast to our previous study on chitosan-coated filters, where a significant decline in antibacterial efficacy was observed as the relative humidity increased [19]. The moisture stability of lactoferrin can likely be attributed to its unique structural properties. Unlike linear polysaccharides like chitosan, which may undergo swelling or charge neutralization in high-humidity environments, lactoferrin is a globular glycoprotein with a more stable tertiary structure. This stability ensures that its active antimicrobial sites remain accessible and functional even in humid conditions, highlighting the superior potential of lactoferrin-coated filters for practical applications in subtropical climates or damp indoor environments.

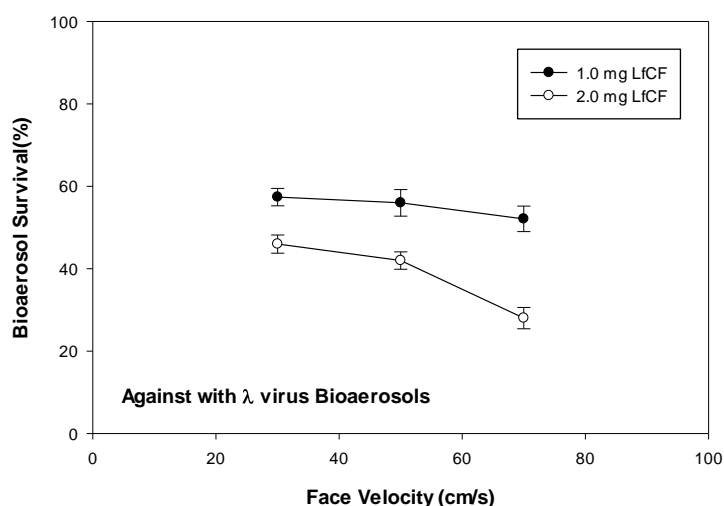

Figure 5. Effect of relative humidity (30%, 50%, and 70%) on the survival rates of λ virus bioaerosols collected from the lactoferrin-coated filters (2.0 mg) at a face velocity of 10 cm/s.

3.4. Application of LfCFs in Field Indoor Environments

This work applied LfCFs in a real indoor environment to understand their bioaerosol field removal capacity, following the methodology established in our previous study [19]. A dental clinic was chosen as the testing room. The size of the testing room was $3 \times 3 \times 1.8 \text{ m}^3$. A self-made air-cleaning device was fabricated with a $220 \times 200 \times 160 \text{ mm}^3$ stainless-steel body-box and DC-powered fan (12 V, diameter 40 mm, mounted in air intake side). A diameter 100 mm filter holder was installed on the opposite side of the body-box as an exhaust (shown as Figure 5). An untreated air filter or 2.0 mg lactoferrin-coated filter could be placed into the holder to clean the indoor air intake using a fan with 10 cm/s velocity.

This self-made air-cleaning device was applied approximately 3 h after the end of a day-long dental operation. The bacterial bioaerosols were sampled in triplicate by a BioSampler (SKC Inc., USA) at intervals of 30 min, followed by the collection and cultivation process described in Section 2.4.

The variations in bacterial bioaerosol concentrations over the operation period are illustrated in Figure 6. The initial indoor bacterial concentration was recorded at $1543 \pm 156 \text{ CFU/m}^3$. Upon activating the filtration system, the concentration rapidly decreased to $311 \pm 34 \text{ CFU/m}^3$ within the first 90 minutes. Subsequently, the concentration stabilized, reaching a final level of $257.9 \pm 38 \text{ CFU/m}^3$ at 210 min. This corresponds to an overall removal efficiency of approximately 83.3%, demonstrating the practical applicability of the lactoferrin-coated filter for indoor air quality improvement.

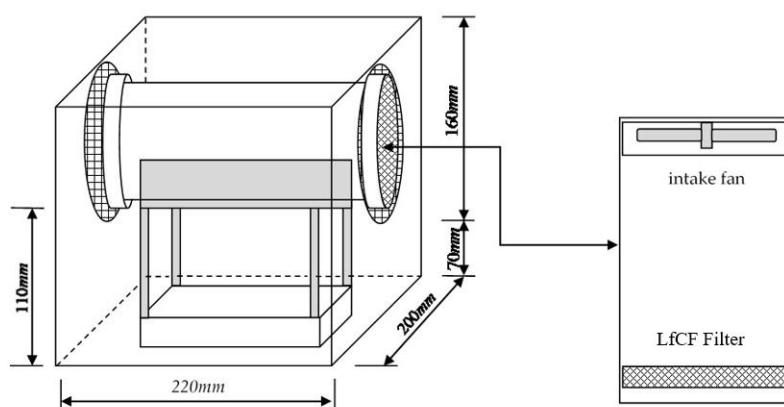

Figure 6. Schematic diagram of self-made air-cleaning device.

4. Discussion

4.1. Broad-Spectrum Antimicrobial Mechanisms: From Bactericidal to Antiviral Activity

The most significant finding of this study is the ability of lactoferrin-functionalized filters to effectively inactivate both bacterial (*E. coli*) and viral (λ virus) bioaerosols. This broad-spectrum efficacy can be attributed to the unique biochemical properties of the bovine lactoferrin peptide (Lactoferricin B) utilized in the coating.

For Gram-negative bacteria like *E. coli*, the primary mode of action is driven by the cationic nature of the lactoferrin peptide. The peptide carries a net positive charge, facilitating a strong electrostatic attraction to the negatively charged lipopolysaccharides (LPS) on the bacterial outer membrane [21,28]. Upon binding, the peptide penetrates and disrupts the membrane integrity, leading to the leakage of intracellular contents and subsequent cell death. Additionally, although less dominant in peptide-based forms compared to the whole protein, the iron-sequestering capability of lactoferrin may also contribute by depriving bacteria of iron, an essential nutrient for their growth and metabolic maintenance [22,29].

Regarding the antiviral activity against λ virus, the mechanism differs but is equally effective. λ virus is a non-enveloped DNA virus protected by a protein capsid. Previous studies suggest that lactoferrin inhibits viral infection primarily by blocking the adsorption phase [23,24]. The immobilized lactoferrin peptides on the filter fibers can interact with the viral capsid proteins through charge-based interactions. This binding can either structurally destabilize the virus or sterically hinder the viral tail fibers from recognizing and attaching to the specific receptors on the host *E. coli* cells. This dual capability—membrane disruption in bacteria and adsorption blocking in viruses—highlights the superiority of lactoferrin as a versatile antimicrobial agent for air filtration applications, offering a distinct advantage over agents that target specific metabolic pathways often limited to a single class of microorganisms.

4.2. Implications for Occupational Hygiene and Exposure Control

From an occupational hygiene perspective, implementing effective engineering controls is the preferred strategy for reducing hazardous exposures. While existing antimicrobial technologies such as silver (AgNPs), copper oxide (CuO), and photocatalytic TiO₂ demonstrate high inactivation efficiencies [16,17], their integration into HVAC systems introduces new occupational risks. Studies have indicated that the detachment of metal nanoparticles can lead to potential inhalation toxicity for building occupants [17]. Similarly, photocatalytic systems often require UV irradiation, which consumes energy and entails complex maintenance to prevent UV leakage or ozone generation—a known respiratory irritant [11].

In contrast, the lactoferrin-functionalized filter developed in this study aligns with the principles of Safe-by-Design. Bovine lactoferrin is a GRAS (Generally Recognized As Safe) protein. Its inherent biocompatibility ensures that even if trace amounts are released, they pose negligible health risks, eliminating the “chemical hazard” often associated with active disinfection systems. By functioning as a passive, energy-independent engineering control, LfCFs provide a sustainable solution that enhances indoor air quality (IAQ) without introducing secondary occupational hazards, satisfying the safety requirements for continuous operation in staffed environments.

4.3. Environmental Stability: Overcoming the Humidity Limitation of Biopolymers

A critical challenge in the development of bio-based air filters is their susceptibility to environmental moisture. Hydrophilic biopolymers, such as chitosan and alginate, are prone to water absorption in high-humidity environments. Our previous study demonstrated that the antimicrobial efficiency of chitosan-coated filters decreased significantly as the relative humidity (RH) increased from 30% to 70% [19]. This phenomenon is largely attributed to the swelling of the polysaccharide matrix, which can increase the distance between the cationic charge centers and the microbial surface,

or lead to the shielding of active amine groups by water molecules, thereby weakening the electrostatic interaction required for cell capture and lysis [20,25].

In contrast, the results of this study (Figure 4) reveal that the lactoferrin-functionalized filters exhibit remarkable stability against humidity variations. The inactivation efficiencies against both bacterial and viral bioaerosols showed no significant difference ($p > 0.05$) across the tested RH range of 30–70%. This superior stability can be explained by the structural differences between the two biopolymers. Unlike the linear, flexible chains of chitosan, lactoferrin is a globular glycoprotein with a compact, well-defined tertiary structure stabilized by disulfide bonds [21]. This rigid conformation protects its active antimicrobial peptide motifs (e.g., Lactoferricin B) from conformational changes or excessive hydration effects even under humid conditions. Furthermore, the amphipathic nature of the lactoferrin peptides ensures that they remain active at the air-liquid interface formed on the fiber surface, maintaining their ability to insert into microbial membranes effectively.

The ability to maintain consistent performance under high-humidity conditions is of significant practical value, particularly for applications in subtropical climates or within HVAC systems where cooling coils often generate damp environments. The lactoferrin-coated filter therefore represents a robust solution that overcomes the major “moisture-sensitivity” bottleneck inherent to traditional biopolymer-based filtration technologies.

4.4. Practical Application and Risk Reduction in High-Risk Healthcare Settings

While laboratory studies determine intrinsic kinetic parameters, validating performance in realistic use scenarios is essential for public health interventions. Dental clinics represent a quintessential high-risk environment, where aerosol-generating procedures (AGPs) continuously release pathogens into the breathing zone [7]. In our field test, the LfCF system achieved an ~83% reduction in bacterial bioaerosols (Figure 7), effectively reducing the “infectious dose” available for transmission.

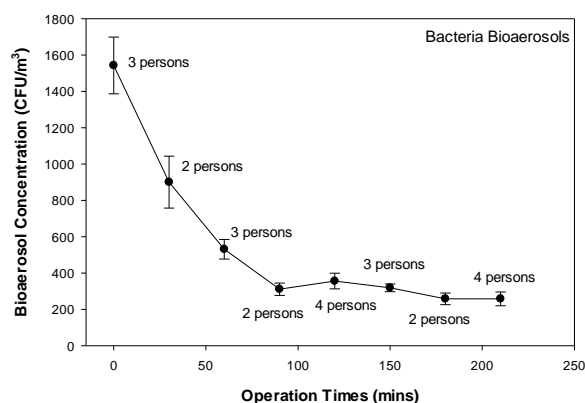

Figure 7. Survival of bacterial bioaerosols by using the 2.0 mg LfCF filter in the testing room.

This performance is particularly relevant to the recent ASHRAE Standard 241, which emphasizes the delivery of equivalent clean airflow to mitigate infection risks [15]. Beyond immediate removal, a critical hygiene advantage of the LfCF is its potential to prevent secondary aerosolization. In traditional filters, captured microorganisms can form biofilms, leading to clogging or the release of pathogens during filter replacement—a significant exposure risk for maintenance personnel [14]. The broad-spectrum antimicrobial activity of lactoferrin inhibits this biological proliferation [27]. Consequently, LfCFs serve a dual function: protecting occupants by reducing airborne pathogen loads and protecting maintenance workers by minimizing the bio-burden on filter media. This makes them a robust engineering control suitable for healthcare facilities, long-term care centers, and other high-density indoor environments.

5. Conclusions

In conclusion, this study demonstrates that lactoferrin-functionalized filters (LfCFs) serve as a highly effective engineering control for mitigating occupational bioaerosol exposure. Unlike traditional passive filters that risk becoming breeding grounds for pathogens, the LfCF system actively inactivates both bacterial and viral aerosols through a broad-spectrum mechanism. Crucially, the coating maintains its efficacy under high-humidity conditions (up to 70% RH), overcoming the moisture-instability limitations observed in other biopolymers like chitosan.

From a practical hygiene perspective, the successful field validation in a dental clinic confirms the filter's applicability in real-world high-risk settings. By significantly reducing the airborne bio-burden, this technology not only protects occupants but also mitigates the risk of secondary aerosolization during filter maintenance—a critical safety enhancement for facility management personnel. Furthermore, as a biocompatible and “Safe-by-Design” material, lactoferrin offers a sustainable alternative to inorganic biocides (e.g., silver or photocatalysts), aligning with current trends in green occupational health interventions. Future work will focus on long-term durability testing to further support its integration into standard HVAC maintenance protocols.

Author Contributions: Conceptualization, S.Y.; methodology, S.Y. and Y.-F.H.; software, S.Y. and C.-Y.C.; validation, S.Y. and Y.-F.H.; formal analysis, H.-C.H.; investigation, S.Y.; resources, S.Y.; data curation, S.Y. and C.-Y.C.; writing—original draft preparation, S.Y.; writing—review and editing, S.Y. and C.-Y.C.; visualization, S.Y. and C.-Y.C. All authors have read and agreed to the published version of the manuscript.

Funding: This study was supported by the National Science Council of Republic of China project.

Institutional Review Board Statement: Not applicable.

Informed Consent Statement: Not applicable.

Data Availability Statement: The data supporting the results in the current study are available from the corresponding author on reasonable request.

Conflicts of Interest: The authors declare no conflict of interest.

References

1. Leung, N.H.L.; Chu, D.K.W.; Shiu, E.Y.C.; Chan, K.-H.; McDevitt, J.J.; Hau, B.J.P.; Yen, H.-L.; Li, Y.; Ip, D.K.M.; Peiris, J.S.M.; et al. Respiratory virus shedding in exhaled breath and efficacy of face masks. *Nat. Med.* **2020**, *26*, 676–680.
2. World Health Organization. *WHO Guidelines for Indoor Air Quality: Dampness and Mould*; WHO Regional Office for Europe: Copenhagen, Denmark, **2009**.
3. NIOSH. *Hierarchy of Controls*; National Institute for Occupational Safety and Health: Washington, DC, USA, **2015**. Available online: <https://www.cdc.gov/niosh/topics/hierarchy/default.html> (accessed on 6 February 2026).
4. Millyard, A.; Santos, J.D.; Voisey, C.R. Antimicrobial Surface Coatings for Air Purification and Inactivation of Bioaerosols: A Review. *Appl. Sci.* **2021**, *11*, 7526.
5. Zhang, Z.; Ji, H.; He, D. Recent advances in antimicrobial air filters for controlling bioaerosols: A review. *Sep. Purif. Technol.* **2022**, *297*, 121516.
6. Innocenzi, P.; Stagi, L. Carbon-Based Antiviral Nanomaterials: Graphene, Fullerenes, and Carbon Quantum Dots. *Chem. Sci.* **2020**, *11*, 6606–6622.
7. Mandal, J.; Overmans, S. Potential of air filters and masks in the fight against airborne transmission of SARS-CoV-2. *Appl. Microbiol. Biotechnol.* **2020**, *104*, 9959–9969.
8. Morawska, L.; Milton, D.K. It Is Time to Address Airborne Transmission of Coronavirus Disease 2019 (COVID-19). *Clin. Infect. Dis.* **2020**, *71*, 2311–2313.
9. Yang, S.; Chuang, C.-Y.; Huang, H.-C.; Fang, W. Inactivation of Avian Influenza Virus Aerosol Using Membrane-Less Electrolyzed Water Spraying. *Aerobiology* **2023**, *1*, 6–18.

10. Chuang, C.-Y.; Hsu, Y.-F.; Yang, S. Inactivating Ability Evaluation on Bioaerosols by Carbon-Nanotube Coated Plasma Treatment for Indoor Air Cleaning. *Coatings* **2022**, *12*, 1497.
11. Dubuis, M.-E.; Dumont-Leblond, N.; Laliberté, C.; Veillette, M.; Turgeon, N.; Duchaine, C. Ozone efficacy for the control of airborne viruses: Bacteriophage and eukaryotic viruses. *PLoS ONE* **2020**, *15*, e0231164.
12. Liu, K.; Cheng, X.; Chang, Y.; Li, J.; Zhang, L.; Wei, J. Bioaerosol generation from the collection of fungal spores on air filter materials: The effect of relative humidity and airflow velocity. *Build. Environ.* **2021**, *188*, 107433.
13. Schlueter, J.; Mott, R. Protocols for the Assessment of Bioaerosol Re-entrainment from HVAC Filters. *ASHRAE Trans.* **2020**, *126*, 3–10.
14. Forth, K.A.; Pasanen, A.-L.; Rautio, S. Bioaerosol exposure in indoor air cleaning and maintenance. *Ann. Work. Expo. Health* **2021**, *65*, 111–123.
15. ASHRAE. *Standard 241-2023: Control of Infectious Aerosols*; American Society of Heating, Refrigerating and Air-Conditioning Engineers: Atlanta, GA, USA, **2023**.
16. Hamada, A.; Minuki, S.; Honda, T. Inactivation of airborne viruses using a TiO₂ photocatalyst. *J. Biosci. Bioeng.* **2022**, *133*, 495–500.
17. Pal, M.; Khan, J. Antimicrobial efficacy of silver nanoparticles in air filtration: A systematic review. *Environ. Technol. Rev.* **2021**, *10*, 120–135.
18. Mi, X.; Su, Z. Moisture sensitivity of biopolymer-based air filters: Challenges and solutions. *Sustain. Mater. Technol.* **2023**, *36*, e00621.
19. Hsu, Y.-F.; Chuang, C.-Y.; Yang, S. Evaluation of the Bioaerosol Inactivation Ability of Chitosan-Coated Antimicrobial Filters. *Int. J. Environ. Res. Public Health* **2021**, *18*, 7183.
20. Verbeke, F.; Bonne, K. The influence of relative humidity on the filtration performance of electrospun chitosan nanofibers. *Polymers* **2022**, *14*, 328.
21. Superti, F. Lactoferrin from Bovine Milk: A Protective Companion for Life. *Nutrients* **2020**, *12*, 2562.
22. Embleton, N.D.; Berrington, J.E. Lactoferrin: Antimicrobial mechanisms and clinical applications. *Semin. Fetal Neonatal Med.* **2013**, *18*, 143–149.
23. Wakabayashi, H.; Oda, H.; Yamauchi, K.; Abe, F. Lactoferrin for protection against virus infections. *J. Infect. Chemother.* **2014**, *20*, 666–671.
24. Drago-Serrano, M.E.; Campos-Rodríguez, R.; Carrero, J.C.; de la Garza, M. Lactoferrin: A Bioactive Protein to Control Viral Infections. *Nutrients* **2017**, *9*, 261.
25. Wang, B.; Timilsena, Y.P.; Blanch, E.; Adhikari, B. Lactoferrin: Structure, function, denaturation and digestion. *Crit. Rev. Food Sci. Nutr.* **2019**, *59*, 580–596.
26. Ammons, M.C.B.; Copié, V. Clinical applications of lactoferrin as a biofilm inhibitor. *Adv. Exp. Med. Biol.* **2013**, *973*, 237–246.
27. Siqueira, C.P.; Bueno, J. Lactoferrin-coated surfaces for preventing biofilm formation: A promising strategy. *Colloids Surf. B Biointerfaces* **2023**, *222*, 113045.
28. Jenssen, H.; Hancock, R.E. Antimicrobial properties of lactoferrin. *Biochimie* **2009**, *91*, 19–29.
29. Kell, D.B.; Heyden, E.L.; Pretorius, E. The biology of lactoferrin, an iron-binding protein that can help defend against viruses and bacteria. *Front. Immunol.* **2020**, *11*, 1221.

Disclaimer/Publisher's Note: The statements, opinions and data contained in all publications are solely those of the individual author(s) and contributor(s) and not of MDPI and/or the editor(s). MDPI and/or the editor(s) disclaim responsibility for any injury to people or property resulting from any ideas, methods, instructions or products referred to in the content.