

Review

Not peer-reviewed version

Research on Energy-Saving Applications and Strategies of Microcontrollers in Multiple Domains: Bibliometric Analysis and Case Studies

[Yuxuan Yao](#)*, [He Huang](#), [Boyu Wang](#), [Zhili Ma](#)

Posted Date: 28 October 2025

doi: 10.20944/preprints202510.2164.v1

Keywords: microcontrollers; energy-saving strategies; renewable energy; bibliometric analysis; grid load management



Preprints.org is a free multidisciplinary platform providing preprint service that is dedicated to making early versions of research outputs permanently available and citable. Preprints posted at Preprints.org appear in Web of Science, Crossref, Google Scholar, Scilit, Europe PMC.

Copyright: This open access article is published under a Creative Commons CC BY 4.0 license, which permit the free download, distribution, and reuse, provided that the author and preprint are cited in any reuse.

Disclaimer/Publisher's Note: The statements, opinions, and data contained in all publications are solely those of the individual author(s) and contributor(s) and not of MDPI and/or the editor(s). MDPI and/or the editor(s) disclaim responsibility for any injury to people or property resulting from any ideas, methods, instructions, or products referred to in the content.

Review

Research on Energy-Saving Applications and Strategies of Microcontrollers in Multiple Domains: Bibliometric Analysis and Case Studies

Yuxuan Yao ^{1,*}, He Huang ², Boyu Wang ¹ and Zhili Ma ³

¹ Affiliation 1; Chongqing University, Huxi Campus, Chongqing University-Cincinnati University Joint Institute, Chongqing 400044, China

² Affiliation 2; Sichuan Energy Internet Research Institute, Tsinghua University, Chengdu, Sichuan 610000, China

³ Affiliation 3; School of Construction Management and Real Estate, Chongqing University, Chongqing 400044, China

* Correspondence: yaoy8@mail.uc.edu

Abstract

With the continuous growth of energy consumption and the increasing importance of energy conservation and emission reduction, microcontrollers, as an efficient control technology, have great potential in the field of energy saving. This paper investigates the application of microcontrollers in the energy-saving sector, focusing on grid optimization, distribution transformer energy consumption management, and intelligent control systems. Through bibliometric analysis, literature was selected from the Web of Science database, and network mapping analysis was conducted using Vosviewer to reveal the main themes, development trends, and hot topics in microcontroller-based energy-saving research. Additionally, case studies were employed to explore the energy-saving mechanisms and technological pathways of microcontrollers in various fields, especially in the power grid domain. The research shows that microcontrollers can effectively improve device efficiency and reduce energy waste by optimizing control strategies and intelligent adjustment mechanisms. Particularly in grid and distribution transformer energy consumption management, the integration of microcontrollers significantly enhances the stability and efficiency of the system, especially by dynamically adjusting and monitoring in real time, thereby optimizing power supply and energy flow. Finally, this paper proposes future research directions, emphasizing the integration of microcontrollers with reinforcement learning, the Internet of Things, renewable energy, and other fields, aiming to achieve more efficient energy-saving strategies and provide experience for the optimization and promotion of microcontroller-based energy-saving technologies.

Keywords: microcontrollers; energy-saving strategies; renewable energy; bibliometric analysis; grid load management

1. Introduction

With the rapid increase in global energy consumption, improving energy efficiency and reducing energy waste have become an important research issue worldwide [1]. Traditional energy systems are not only constrained by resource depletion and environmental pollution but also face practical challenges such as improving energy efficiency and reducing energy consumption. Particularly in power systems, factors like load fluctuations, inefficient transformers, and unreasonable energy structures lead to significant energy waste. To address this challenge, intelligent control systems and high-performance hardware devices have become key areas of research, and microcontrollers, as an essential control unit, hold significant potential for application in the energy-saving field [2,3].

In the application of microcontroller technology, a substantial body of research has demonstrated that microcontrollers can significantly improve energy utilization efficiency through precise control and optimization strategies. Existing studies have proposed energy-saving applications of microcontrollers in fields such as smart agriculture [4], power systems [5], and industrial automation. The energy-saving strategies of microcontrollers have evolved from passive energy-saving to active energy-saving and integration with renewable energy sources [6]. With the continued growth in global energy demand and increasingly stringent environmental protection requirements, improving grid efficiency and reducing energy waste has become a key challenge facing the global power industry [7]. Microcontrollers, with their efficient and flexible characteristics, play a vital role in various stages of power systems. For example, in grid load management, microcontrollers can dynamically adjust power distribution by monitoring load variations in real time, optimizing the utilization of power resources. In the energy consumption management of distribution transformers, microcontrollers can precisely control the operating status of transformers, reducing no-load losses and load losses, thereby significantly improving the transformer's energy efficiency ratio [8].

However, the application and research of microcontrollers still face certain limitations. First, the computing power and storage capacity of microcontrollers are limited, which often becomes a bottleneck when handling complex control tasks. For example, when dealing with large-scale equipment clusters, microcontrollers may struggle to efficiently process massive real-time data, thereby affecting the overall performance of the system. Secondly, existing research has primarily focused on individual domains, lacking cross-disciplinary, integrative studies [9], such as applications combining microcontrollers with popular intelligent technologies like reinforcement learning and the Internet of Things. Finally, although microcontrollers have been applied in some renewable energy projects [10], more in-depth technological innovation and broader practical exploration are still required to achieve efficient management of large-scale renewable energy, optimize energy storage system configurations, and smooth the intermittent fluctuations of renewable energy.

Therefore, this paper adopts a research methodology combining bibliometric analysis and case study analysis. First, through bibliometric analysis based on the Web of Science database, this paper selects literature related to microcontroller-based energy saving and conducts an analysis of its temporal and spatial distribution, keyword indexing, and highly cited papers. This approach helps trace the development of microcontroller energy-saving research and reveals the research hotspots and trends in this field. Additionally, the paper uses case studies to delve into the applications of microcontrollers in fields such as industrial control, smart agriculture, and Internet of Things (IoT) devices. It analyzes the mechanisms and technological pathways through which microcontrollers achieve energy savings in different scenarios and further examines their applications in the power grid sector. Finally, recommendations are provided for the application of microcontrollers in the energy-saving domain. The aim of this research is to serve as a reference for the further development of microcontroller technology in the field of energy saving.

2. Research Method

This study focuses on energy conservation issues related to microcontrollers. First, literature was retrieved from the Web of Science Core Collection to ensure comprehensiveness and representativeness. During the retrieval process, multiple parameters were set, including keywords, search scope, time span, and article types. Advanced searches were conducted using Boolean operators to filter literature relevant to the field of energy-saving applications of microcontrollers. Subsequently, the scientometric software VOSviewer was used to perform statistical analysis and network mapping on the selected literature, revealing the main research themes, development trends, and hotspot topics in the field. By analyzing clusters, leading journals, highly cited publications, and the spatiotemporal distribution of keywords, this study systematically summarizes the current state

of research in the field and forecasts future research directions, thereby providing valuable references for further exploration.

Second, this study adopts a case study approach to investigate in depth the energy-saving applications of microcontrollers across different domains. The case study method, by analyzing concrete examples, helps researchers better understand the practical effectiveness of microcontroller-based energy-saving solutions [11]. Through detailed analysis of multiple representative cases—such as those in industrial control, smart agriculture, and IoT devices—this paper examines the energy-saving mechanisms and technical pathways of microcontrollers in diverse scenarios. For each case, the study analyzes the background, implementation methods, and energy-saving outcomes, supported by both quantitative and qualitative data. This reveals the key factors and challenges associated with energy-efficient microcontroller applications. Through comprehensive case analysis, the study offers valuable practical insights for optimizing and promoting microcontroller-based energy-saving technologies.

Finally, the study summarizes related research findings and proposes a future research direction that integrates microcontrollers with reinforcement learning to achieve more efficient energy-saving strategies and reduce overall energy consumption. The detailed research flow is illustrated in Figure 1.

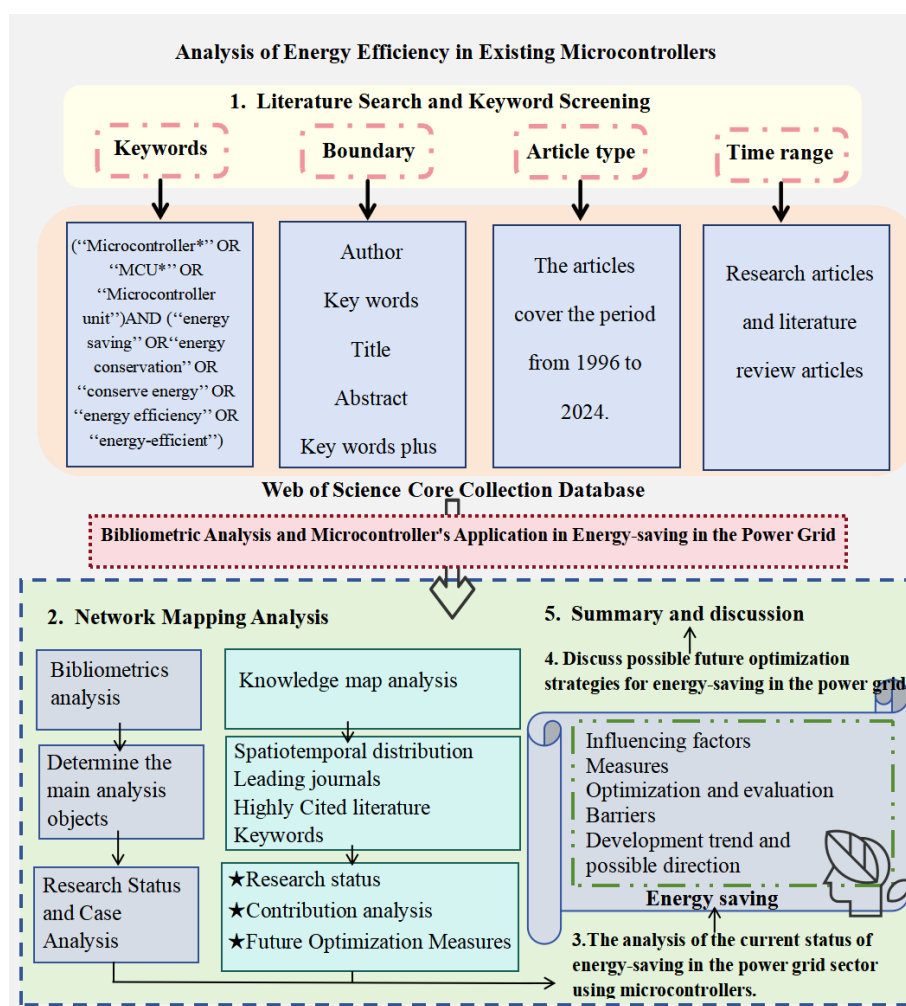

Figure 1. Research Framework.

2.1. Bibliometric Analysis and Mining

The data in this study were obtained from the Web of Science (WOS) Core Collection, including SCI-Expanded, SSCI, CPCI-S, and CPCI-SSH. A combination of basic and advanced search methods

was employed to ensure comprehensive data retrieval. The search formula used was:(TS = "Microcontroller*" OR TS = "MCU*" OR TS = "Microcontroller unit") AND (TS = "energy saving" OR TS = "energy conservation" OR TS = "conserve energy" OR TS = "energy efficiency" OR TS = "energy-efficient").

Here, TS is the field tag indicating "Topic," which includes the title, abstract, author keywords, and Keywords Plus. The term Microcontroller refers to microcontrollers or MCUs. Quotation marks indicate that the enclosed terms must appear adjacent to each other, and individual words will not be matched separately. The document types were limited to articles and review articles. The search time span was set to include all available years to facilitate the analysis of development trends. The search results covered the period from 1996 to 2024, yielding a total of 854 relevant publications after screening. The study proceeds to perform bibliometric analysis and extract relevant research content through network mapping.

Bibliometrics, by applying mathematical methods for statistical analysis and visualization, can effectively reveal the network structure of a research field. CiteSpace and VOSviewer are commonly used standard tools for such analysis [12]. By examining co-occurrence, co-citation, authorship, and keywords, researchers can gain in-depth insights into the current state and development trends of a given field [13].

This study first utilized the visualization tool VOSviewer to analyze the 854 publications. VOSviewer is a free software with robust data processing capabilities and the ability to visually present analysis results. In VOSviewer, the size of nodes and fonts corresponds to the number of publications, while the width and distance of connecting lines indicate the strength of relationships between nodes. Different colors represent different research clusters.

By visually analyzing aspects such as publication content, countries, institutions, journals, highly cited literature, and keywords, the study proposes six quantitative analytical indicators. These indicators include: Total Citations (TC); Average Citations (AC); Proportion of documents within the total sample (%/854); Average Publication Year (APY). Among these, AC refers to the ratio of total citations to the total number of publications and reflects the average impact of each paper. However, this indicator may be influenced by a few highly cited publications.

2.2. Case Study Method

The case study method, also known as the individual case analysis or typical analysis method, is a scientific analysis approach that involves in-depth and detailed research of representative phenomena or entities to reveal the overall system's laws Rashid [14].

This method emphasizes extracting potential universal principles by closely examining specific individuals, events, or cases, in order to provide theoretical support and practical guidance for broader research [15,16]. This paper aims to explore the application effectiveness of microcontrollers in the field of energy saving through case studies, particularly in various areas of industrial control, such as transformers, distribution grids, and other electrical equipment aimed at improving energy efficiency. By selecting these typical devices as the research objects and combining the specific applications of microcontroller technology within them, this study systematically analyzes their energy-saving potential and actual effects. Specifically, this paper will compare the energy consumption changes of different devices before and after the implementation of microcontroller control, exploring how microcontrollers achieve energy savings and consumption reduction through intelligent adjustment and optimized control.

Through a thorough examination of the case study results, this paper not only focuses on the application effects of microcontrollers in individual devices but also attempts to summarize common energy-saving principles applicable across multiple fields, aiming to provide guidance and insights for the energy-saving potential of microcontrollers in future, broader application scenarios.

3. Bibliometric Analysis Results

3.1. Temporal and Spatial Distribution and Representative Journals

The analysis of temporal and spatial distribution includes examining the number of publications over different time periods, as well as the corresponding countries and institutions. Representative journals refer to those that publish the highest number of articles related to the research topic. By analyzing the temporal and spatial distribution along with representative journals, researchers can intuitively observe the development trends of microcontroller-based energy-saving research.

In terms of publication quantity, as shown in Figure 2, research on microcontroller energy saving began in 1996, with two papers published that year. Early research (1996-2007) was relatively limited. Between 2008 and 2016, the annual number of publications fluctuated around 50 papers, while from 2017 to 2024, the number of published papers exceeded 100 annually. Overall, the total number of publications from 1996 to 2024 was 854, showing a fluctuating upward trend. This indicates that global scholars have increasingly focused on microcontroller energy-saving issues.

From the perspective of the countries where the papers were published, as shown in Figure 3, the top three countries with the highest number of publications are China (11 papers), the United States (9 papers), and India (14 papers).

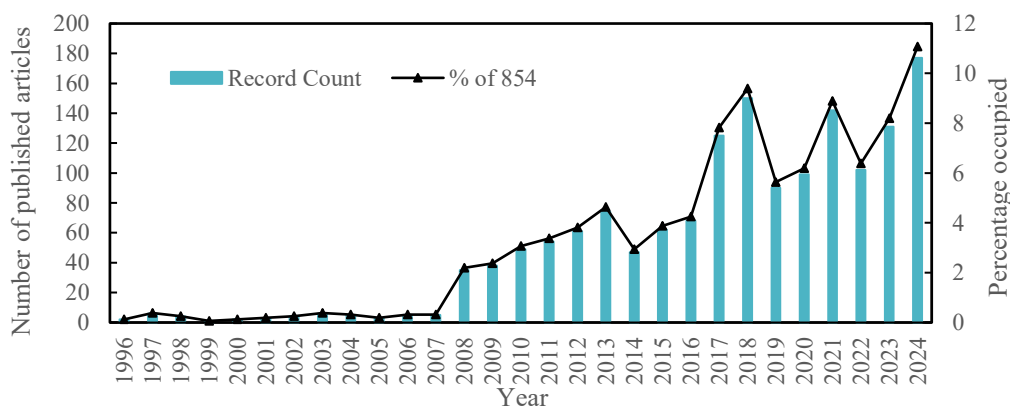

Figure 2. Chart of changes in the number of published articles.

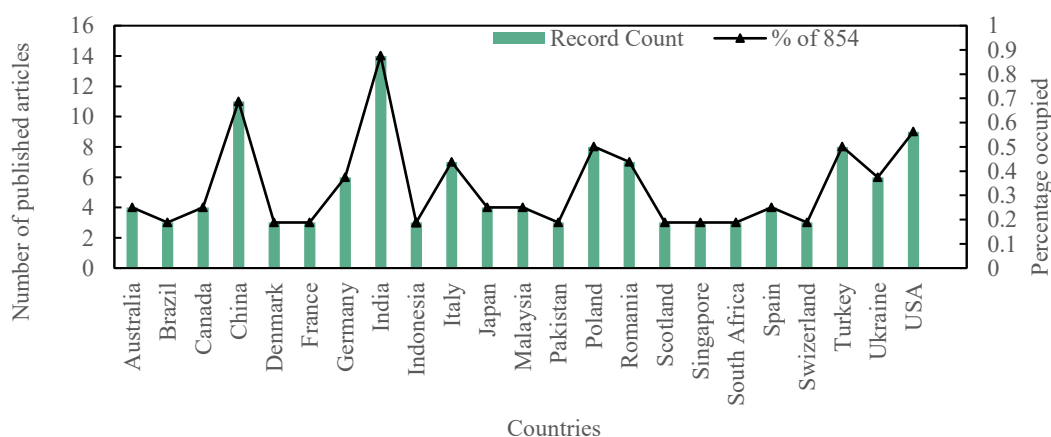

Figure 3. Map of the number of published articles by country.

Further analysis of international collaboration reveals the most active countries by restricting the number of publications and citations. The cooperation between these countries is shown in Figure 4, where the distance between nodes represents the strength of collaboration. The countries in the figure are distributed globally, with major collaborative countries including China, the United States,

India, and the United Kingdom. China exhibits strong collaboration with India, the United States, the United Kingdom, and other countries, while some other countries, such as Italy, France, and Japan, show relatively weaker collaborative ties. Countries involved in international cooperation tend to have higher publication and citation counts compared to those not participating in collaboration. This suggests that international cooperation and academic exchange effectively promote the development of scientific knowledge and enhance research output.

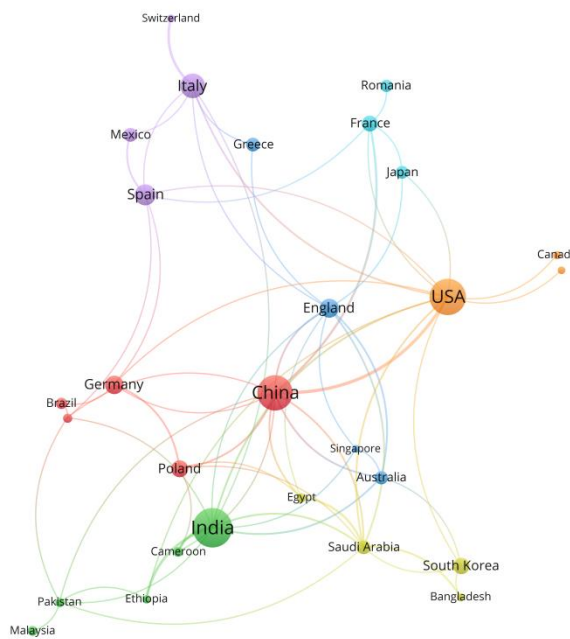

Figure 4. Country contribution map.

Journal bibliometric analysis helps scholars quickly and intuitively assess the quality and impact of journals. As shown in Figure 5, among the papers on microcontroller energy-saving research, the journals 《Sensors》、《IEEE Sensors Journal》、《IEEE Transactions on Instrumentation and Measurement》、《IEEE Access》、《Computers & Electrical Engineering》、《Electronics》、《Microprocessors and Microsystems》、《Applied Sciences-Basel》《IEEE Transactions on Industrial Informatics》 are the most frequently cited. SCI journals are divided into Q1-Q2 journals and Q3-Q4 journals, with Q1-Q2 journals slightly outnumbering Q3-Q4 journals. The number of publications in a journal is related to the journal's difficulty level, and the statistical results align with actual conditions. Researchers studying microcontroller energy consumption simulation and optimization can choose suitable journals based on these statistical results and their own circumstances.

strategies for achieving energy efficiency in microcontroller system design through low-power design [17], optimized power and energy management. In particular, the design of low-power modes and microcontroller units is crucial for reducing the overall system energy consumption.

The green cluster (4 items) is related to microcontroller design and performance enhancement, including keywords such as field-programmable gate arrays (FPGA), hardware design, and microcontroller-based analog computation. These keywords emphasize improving algorithm performance and system efficiency through the optimization of microcontroller hardware design.

The purple cluster (4 items) involves the energy-efficient application of microcontrollers in the Internet of Things (IoT), with keywords including IoT, smart sensors, wireless sensor networks, remote monitoring, and surveillance. In IoT applications, microcontrollers connect with low-power wireless sensor networks to monitor environmental conditions (e.g., temperature and humidity), enabling intelligent control and automated management. For instance, automatic adjustment of temperature and lighting can help reduce energy consumption [18].

The blue cluster (3 items) concerns power and energy optimization measures in microcontroller applications. Keywords include power management, load balancing, dynamic voltage and frequency scaling (DVFS), energy efficiency, power monitoring and scheduling, energy consumption, and energy efficiency optimization. This cluster focuses on improving power management and energy efficiency. Microcontrollers extend battery life and reduce energy waste through optimized battery usage, enhanced energy efficiency, and low-power hardware design, particularly in portable and battery-powered systems.

The yellow cluster (4 items) addresses the application of microcontrollers in agriculture and precision energy management. Relevant keywords include precision agriculture, irrigation, smart sensors, soil moisture, automation, agricultural management, energy conservation, environmental monitoring, automatic irrigation, and fertilizer management. In precision agriculture, microcontrollers are used in systems such as smart sensors and automatic irrigation, which can automatically adjust the use of energy and water resources according to actual needs, thereby reducing energy waste and improving resource utilization efficiency to achieve energy-saving goals [19].

The light blue cluster (4 items) is related to machine learning and energy optimization, with keywords including machine learning, deep learning, predictive maintenance, edge computing, signal processing, data analysis, artificial intelligence, real-time learning, classification, and fault diagnosis. Machine learning and deep learning can optimize energy management in microcontroller systems. By analyzing real-time data and implementing predictive maintenance, the system can anticipate energy consumption patterns and make adjustments accordingly, reducing unnecessary energy usage. The application of edge computing further reduces processing latency, ensuring real-time and accurate energy efficiency optimization [20].

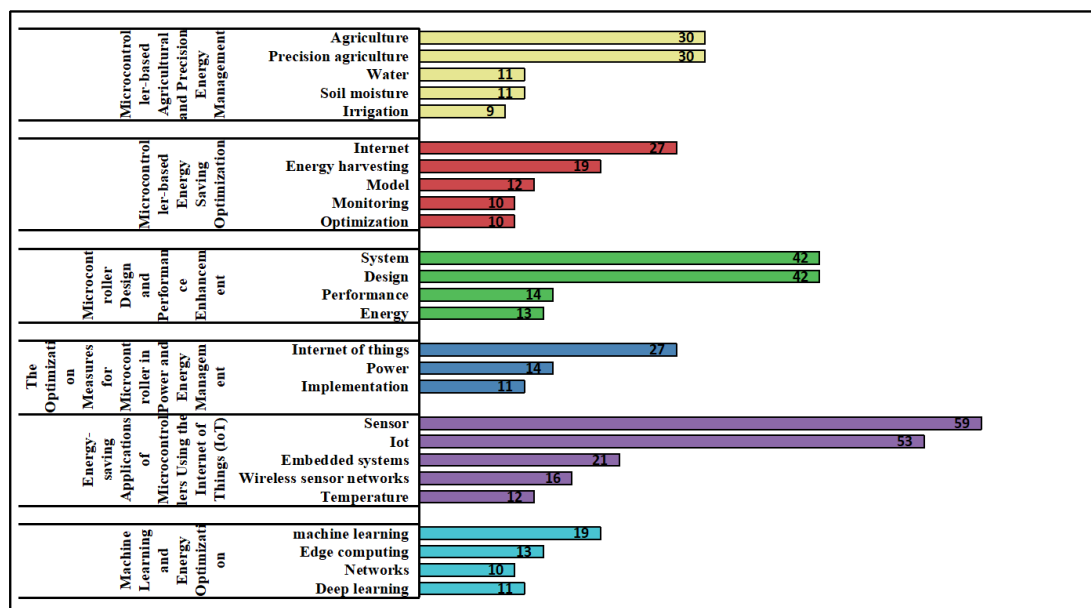

Figure 7. High-frequency keywords in microcontrollers.

Highly cited literature is an important indicator for evaluating the significance of a review article. By setting the minimum number of citations to 80 in the VOSviewer software, this study initially screened 50 highly cited papers from a total of 854 publications. Appendix A presents a quantitative analysis of these highly cited references, among which 30 were published before 2015, and 20 were published in 2015 or later.

The themes of these highly cited papers can be classified into four categories:

- (1) Energy-saving strategies for microcontrollers [21–24];
- (2) Microcontroller integration with renewable energy [25–28];
- (3) Microcontrollers and the power grid [29–32];
- (4) Microcontrollers and reinforcement learning [33–36].

As shown in Figure 8, the total citation count for energy-saving strategies for microcontrollers is the highest. Among these highly cited publications, 26 focus on energy-saving measures, indicating that energy conservation strategies constitute a major area of interest for researchers. In contrast, literature combining reinforcement learning with energy-saving approaches has relatively low total citation counts and is the least represented, with only four studies. This phenomenon may be attributed to the fact that reinforcement learning is a relatively recent field of research, suggesting that future studies integrating reinforcement learning with microcontrollers to optimize energy efficiency still hold significant potential for development.

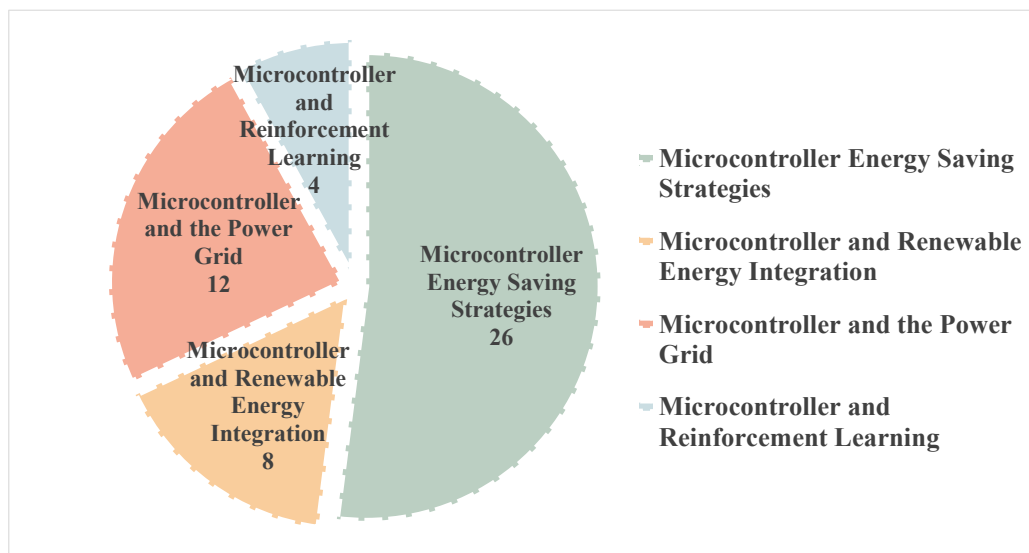

Figure 8. Classification of highly cited literature.

Through a qualitative analysis of keywords and highly cited literature, the following conclusions can be drawn: since the inception of research on energy conservation in microcontroller-based systems, the employed strategies have gradually evolved from solely passive measures to an integrated approach combining passive, active, and renewable energy measures [37,38].

For instance, reference [39] found that in agricultural greenhouses, temperature regulation initially relied solely on low-carbon materials, natural ventilation, and daylight, thereby reducing energy consumption. As demand increased, active control measures were introduced—automatic temperature regulation systems embedded in microcontrollers enabled heating or cooling to manage temperature fluctuations. Ultimately, the system incorporated photovoltaic modules to utilize renewable energy sources for power supply, allowing for independent operation in remote areas.

In the field of power grid energy conservation, the application of microcontrollers has evolved from purely passive energy-saving functions to comprehensive strategies integrating active control and renewable energy. In earlier stages, microcontrollers were mainly used to optimize the operational efficiency of batteries and fuel cells, thereby supporting passive energy-saving functions. With the introduction of renewable energy, their role expanded in hybrid energy systems (HES), where they facilitated not only active control but also synergized with passive strategies to enhance overall energy efficiency. Through dynamic power flow management, microcontrollers have enabled the smooth integration of renewable energy, improved energy utilization, and enhanced grid stability.

At present, the application of microcontrollers not only advances energy systems toward greater efficiency but also contributes to the development of sustainable and reliable power grids [40]. As illustrated by the examples above, the frequency of renewable energy adoption in microcontroller-based energy-saving systems has shown a steady upward trend in tandem with technological advancement and the wider adoption of renewable energy [41].

4. Research Status Analysis and Future Research Trends

4.1. Research Status of Microcontrollers in Various Fields

Microcontrollers, due to their limited memory capacity and low processing power, are generally incapable of performing complex computational tasks. Current research primarily addresses this limitation by integrating microcontrollers with specific applications, thereby simplifying computational tasks or optimizing control processes to achieve efficient operation and energy conservation [42].

In the field of microcontrollers, numerous studies focus on enhancing the performance of the microcontroller itself. For example, Reference [43] proposed a method to optimize convolution operations to improve the performance of the ARM Cortex-M7 microcontroller, particularly in terms of memory and computational overhead during RGB data processing. The study introduced a two-stage optimization approach comprising offline optimization (such as memory layout adjustment and post-training quantization) and online optimization (including loop reordering, memory optimization, software pipelining, and SIMD vectorization). This approach effectively reduces memory usage and enhances computational speed. Compared to the traditional im2col convolution algorithm, the proposed method demonstrates significant improvements in both memory efficiency and processing speed, making it suitable for efficient neural network deployment on resource-constrained devices.

By integrating with hardware such as sensors and actuators, microcontrollers (MCUs) play an essential role in real-time control, data acquisition, and status monitoring tasks. This is especially true in fields like power system optimization, IoT-based energy saving, agricultural energy management, and industrial automation, where they provide efficient solutions. For example, in an intelligent irrigation system, the microcontroller (LPC2148) acts as the core control unit of the irrigation equipment, responsible for processing data from temperature, humidity, light, and rainfall sensors. It also analyzes soil moisture through soil image analysis, ensuring irrigation is triggered when necessary to prevent water waste. Additionally, the microcontroller communicates with farmers' mobile phones via a GSM module, providing real-time feedback on irrigation status, thus enhancing the system's automation and efficiency [44]. The application of microcontrollers in power grids has significantly enhanced the intelligence and power quality of the grid. Through an intelligent grid monitoring system (MSG) based on NodeMCU, the system can monitor power supply current, load current, and harmonics in real time. Users can remotely view and manage the grid status through a cloud platform. This system, combined with a parallel active power filter (SAPF) and gravitational search algorithm (GSA), effectively eliminates harmonics in the grid, optimizing the stability of power supply [45].

Overall, research on microcontrollers spans multiple domains, encompassing not only the enhancement of microcontroller performance itself but also the exploration of diverse application scenarios in combination with specific fields. Through close integration with hardware components such as sensors and actuators, microcontrollers offer efficient and low-power solutions for a wide range of applications. With continuous technological advancements, the application prospects of microcontrollers remain broad, particularly in improving system intelligence and optimizing energy efficiency. Research on microcontrollers is expected to continue providing innovative solutions across various industries.

4.2. Innovations of Microcontrollers in the Energy Sector

4.2.1. Analysis of Energy Consumption Influencing Factors and Causes

The power grid, as an essential part of modern infrastructure, directly impacts the reliability and economy of energy supply through its stability and efficiency. With the continuous growth of global energy demand and increasingly stringent environmental protection requirements, improving the energy efficiency of the grid and reducing energy waste have become a key challenge facing the global power industry [46–48]. In particular, traditional grid systems, which rely on non-renewable energy sources, have certain limitations in areas such as load fluctuations and transformer efficiency, leading to energy waste and inefficient system operation [49].

Against this backdrop, researching the factors influencing energy consumption in the grid is of critical importance. By analyzing these key factors, this study aims to better understand how to optimize control strategies to enhance the operational efficiency and stability of the power grid. This section will delve into the main factors affecting grid energy consumption and explore how

microcontroller technology, through intelligent control systems, can effectively reduce energy waste, thereby improving the overall energy efficiency and stability of the grid.

Energy consumption in the power grid is influenced by a variety of factors, including energy structure, load fluctuations, transformer efficiency, energy storage scheduling capabilities, and the level of intelligent control [50]. Traditional grid systems mainly rely on non-renewable energy sources such as coal and natural gas for power generation. While these sources offer stable power generation, they also bring significant environmental issues. In contrast, modern grids, which integrate large-scale renewable energy sources such as solar and wind power, have inherent volatility and intermittency, significantly increasing the scheduling pressure on energy storage systems and exacerbating power supply instability [51].

Meanwhile, frequent load fluctuations and the inefficient operation of transformers further contribute to energy waste. Additionally, insufficient storage capacity and the rigidity of traditional control strategies make the grid less flexible when responding to complex load changes. In light of these challenges, this section will focus on how microcontroller-based optimization control strategies, such as dynamically adjusting reactive power compensation devices, real-time load demand matching, and improving transformer efficiency, can be employed to reduce energy waste and enhance system resilience, thereby effectively addressing the core issues of energy consumption management in grids with high renewable energy penetration.

(1) Energy Type Impact

In traditional grids, coal-fired power is the primary source of generation. China has abundant coal resources that meet most of its energy needs, and coal-fired power plays an important role in grid regulation, especially in managing load fluctuations and ensuring grid stability. However, the energy efficiency of coal-fired power is low, and carbon emissions are high. With the advancement of carbon reduction targets, the environmental pressure on coal power is growing [52]. Although coal power is still clearly designated as a regulating source in policy documents, grids that overly depend on coal face the dual challenges of high carbon emissions and low energy efficiency.

While natural gas power generation has developed in China, its share in the grid is relatively small, and its dependence on imports introduces certain energy security risks [53]. Under the global push for low-carbon policies, the use of traditional fossil fuels is being restricted, urgently requiring the search for more efficient and environmentally friendly energy solutions.

(2) Load Fluctuations

Load fluctuation refers to the variation or instability of load demand over time within the power system. Grid load changes significantly between peak and off-peak periods [54]. For instance, traditional transformers experience a sharp drop in efficiency during low-load operation, leading to energy waste. Frequent load fluctuations affect both the stability of power supply and the efficiency of transformer operation. In many cases, due to instantaneous fluctuations in load demand, the power grid is unable to flexibly adjust the supply-load balance, resulting in reduced system efficiency when responding to such variations.

(3) Transformer Efficiency

Traditional transformers, under conditions of large load fluctuations, are unable to effectively optimize and adjust dynamically [55]. When the load is low, the ratio of no-load losses to load losses increases, causing a decline in overall system efficiency. For example, traditional oil-immersed transformers may have a no-load loss of up to 1.5 kW and a load loss of 12.6 kW, with these losses being especially severe during low-load operation. Due to the lack of intelligent management, traditional grid systems are unable to automatically adjust operating conditions based on varying load conditions, which makes it difficult to improve the overall efficiency of the system.

(4) Energy Storage and Scheduling

Most traditional power grid systems lack effective energy storage facilities, making it difficult to balance the gap between electricity production and consumption. This issue becomes particularly pronounced with the integration of renewable energy sources such as wind and solar power. Due to

the volatility and unpredictability of these energy sources, the absence of supporting energy storage systems results in power supply volatility and instability. Without energy storage devices, excess electricity cannot be effectively stored, and electricity shortages cannot be immediately supplemented, affecting the overall energy efficiency and reliability of the grid [56].

(5) Level of Intelligent Control

Traditional grid systems lack intelligent control, making it difficult to match power supply with demand in real-time [57]. In modern smart grids, the absence of intelligent control means that transformers and other key equipment cannot be optimized and adjusted based on real-time data. For example, traditional grid energy consumption management relies on manual inspections and regular maintenance, which cannot achieve real-time monitoring and dynamic optimization control [58].

4.2.2. Case Study

It is of great practical significance to further explore the impact factors of energy consumption in the power grid, combining these with real-world application scenarios [59]. Through in-depth analysis of specific cases, we can more intuitively demonstrate the actual effects and application potential of microcontroller (MCU) technology in addressing energy efficiency issues in the power grid. The following will discuss the specific applications of microcontrollers in power grid optimization and transformer energy consumption management, and the energy efficiency improvements they bring. This will provide practical references for the innovative use of microcontroller technology in the energy sector.

As electricity demand increases, countries like China and others face problems of power shortages and load fluctuations, making energy consumption in distribution network transformers an increasingly prominent issue [60]. Additionally, traditional power generation methods rely on non-renewable energy sources and face environmental pollution problems. Due to the lack of intelligent systems and dynamic adjustment capabilities, traditional power grids are unable to efficiently adjust automatically in response to changes in electricity demand, leading to power shortages during peak loads.

At the same time, energy conversion and transmission processes in traditional power grids result in significant energy losses [61]. Without effective energy storage solutions, it becomes difficult to balance energy production and consumption in the grid. Most importantly, traditional grid systems lack support for smart grids, making it challenging to effectively integrate distributed and renewable energy resources, which results in low system efficiency and limited control over environmental pollution.

To address these issues, the reference [61] proposes an intelligent hybrid energy system (HES) based on fuel cells and battery storage, which achieves precise control of the system through microcontrollers, optimizing the stability, reliability, and efficiency of power supply. Reference [62] elaborated on the use of microcontrollers in the automatic energy consumption control system of distribution network transformers. Through intelligent algorithms and real-time control, dynamic optimization of transformer energy consumption is achieved, reducing energy consumption, improving the transformer's adaptability under varying loads, and enhancing the overall system efficiency.

The reference [61] primarily discusses the core role of microcontrollers (such as AVR microcontrollers) in the power grid optimization process, which includes the following aspects:

- (1) Overall System Control and Scheduling: The microcontroller serves as the central control unit of the entire intelligent hybrid energy system. It monitors load demand, the status of the fuel cell stack, and the battery in real time, adjusting the system's operating mode accordingly. Specifically, the microcontroller dynamically determines whether to use battery power, a combination of battery and fuel cell power or switch to fuel cell power alone, based on load

- demand and battery charging status. Through intelligent scheduling, the system is able to maintain an efficient and continuous power supply even in unstable energy environments.
- (2) **Stable Regulation of Voltage and Frequency:** When ensuring grid connectivity, the microcontroller is responsible for regulating the system's output voltage and frequency, reducing power instability caused by fluctuations in renewable energy sources such as wind and solar power. When the fuel cell is the energy source, it can be affected by load fluctuations, potentially causing voltage instability or frequency deviation from the standard range [63]. The microcontroller balances grid frequency and voltage by controlling the power output of the fuel cell in real time, smoothing power fluctuations and improving the power quality and reliability of the grid.
 - (3) **Energy Management and Optimization:** The microcontroller regulates the frequency of current and voltage through pulse-width modulation (PWM) signals, further optimizing the charge and discharge processes of the batteries and fuel cells. For instance, during load changes, the microcontroller responds quickly, adjusting the power supply mode. The system may rely solely on battery power to avoid unnecessary energy waste, or it may simultaneously utilize both the battery and fuel cell to ensure an adequate power supply [64,65]. Through precise adjustments, the microcontroller ensures optimal energy supply, enhancing system efficiency and reducing energy waste.
 - (4) **Energy Storage and Battery Management:** Battery charging management is another key function of the microcontroller. It continuously monitors the state of charge (SOC) of the battery and initiates fuel cell charging when the battery charge falls below a certain threshold. This precise battery management not only extends the lifespan of the battery but also ensures that the battery is charged at the appropriate time, preventing damage due to over-discharge or insufficient charging.

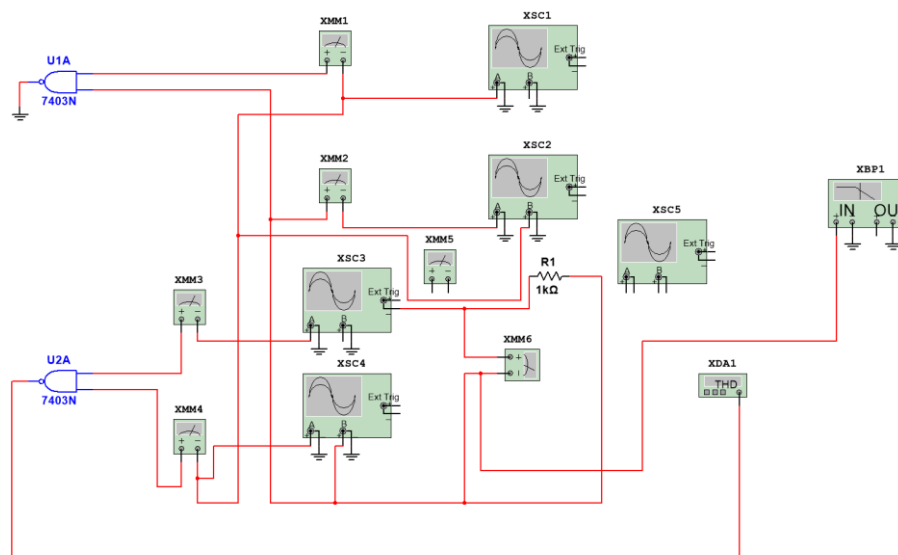

Figure 9. Integration of AVR Microcontroller with Hybrid Energy System.

There are several issues in the energy consumption management of distribution network transformers. Traditional energy management methods rely on manual inspections and periodic maintenance, which cannot achieve real-time monitoring and dynamic optimization control. This leads to a sharp decline in efficiency when transformers operate under low load conditions, and frequent load fluctuations result in low energy utilization efficiency [66]. Additionally, power quality issues, such as harmonics and three-phase imbalance, exacerbate transformer energy consumption and losses, further contributing to energy waste.

With the introduction of microcontrollers, the energy consumption management of the system has been significantly optimized. The optimization role of the microcontroller in the energy consumption management of distribution network transformers is as follows:

- (1) **Assisting in System Architecture and Guiding Hierarchical Design:** The automatic energy consumption control system for distribution network transformers adopts a microcontroller-based hierarchical architecture. The system is divided into user, management, communication, and device layers, with each layer performing different functions. The microcontroller plays a core role in this architecture by making intelligent control decisions and applying optimization algorithms, thus improving the energy utilization efficiency of the transformer and the stability of the system [67].
- (2) **Application of Multi-objective Optimization Algorithms:** In the management layer, the microcontroller implements multi-objective optimization algorithms to develop optimal operating strategies [68]. This algorithm considers factors such as the energy consumption characteristics of the transformer, load demand, and grid operation constraints. For instance, the optimization of no-load losses and load losses, as well as improving voltage quality by adjusting reactive power compensation devices. These strategies are then communicated to the device layer through the communication layer for implementation. Through this intelligent optimization, the transformer can dynamically adjust its operating parameters under different loads and operating conditions, reducing unnecessary energy consumption and improving system energy utilization.
- (3) **Real-time Monitoring and Optimization Control:** The microcontroller, integrated with sensors, collects real-time operational data of the transformer, including voltage, current, and temperature, reflecting the operational status of the transformer. The management layer uses this data for energy consumption analysis and, combined with optimization algorithms (such as genetic algorithms and particle swarm optimization), generates control strategies to optimize the transformer's working state. The optimization objectives include minimizing energy consumption, improving load adaptability, and maintaining voltage deviation within specified limits [68]. For example, the microcontroller helps dynamically adjust the output voltage of the transformer by modifying the position of the transformer's tap changer and the switching state of capacitors, ensuring the transformer operates in the optimal state under varying load conditions and reducing energy consumption.

Experimental results show that after optimization control, the total energy consumption of the transformer per day is significantly reduced. While the energy-saving rate is slightly improved, the optimized transformer's average load rate is also increased. The system can dynamically adjust the transformer's capacity according to load demand, thereby improving the utilization efficiency of the equipment.

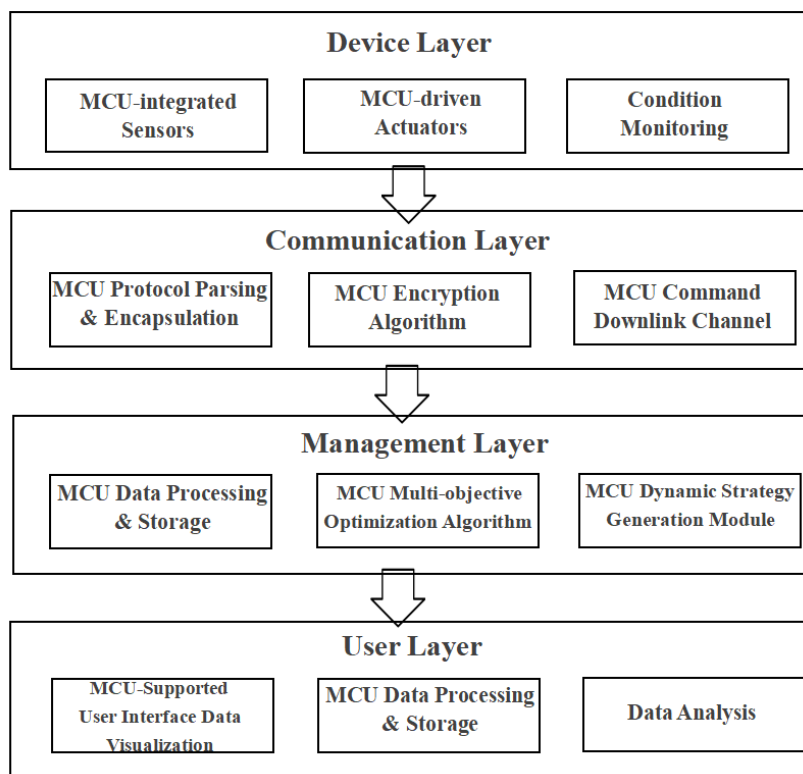

Figure 10. Microcontroller-based Automatic Energy Consumption Control System for Distribution Network Transformers.

Table 1. Comparison of Transformer Energy Consumption Optimization Effects.

| Indicator | Unoptimized | Optimized |
|--------------------------------------|-------------|-----------|
| Daily Total Energy Consumption/(KWh) | 232 ~ 236 | 212 ~ 218 |
| No-load Loss/(KWh) | 25 ~ 27 | 23 ~ 25 |
| Load Loss/(KWh) | 210 ~ 212 | 190 ~ 192 |
| Average Load Factor | 65% ~ 68% | 72% ~ 75% |
| Average Circuit Deviation | 4% ~ 5.5% | 3% ~ 4% |

As energy conservation gradually becomes an essential part of daily life, there is still vast research potential for the development of related technologies, particularly in the fields of intelligent control and energy management, where significant progress is expected in the future [19].

5. Conclusions and Recommendations

This paper has conducted an in-depth analysis of the application of microcontrollers (MCUs) in the energy-saving field, particularly in the energy consumption management of power grids and distribution transformers. It reveals how MCU technology can achieve more efficient energy use through optimized control and intelligent regulation. Through case studies, the paper demonstrates the energy-saving effects of microcontrollers in different application scenarios, highlighting their importance and advantages in practical operations.

In terms of power grid energy efficiency optimization, microcontrollers have enabled real-time monitoring and dynamic regulation of energy consumption by integrating advanced control algorithms and intelligent sensors. For example, the application of microcontrollers in intelligent hybrid energy systems (HES) has significantly enhanced the stability, reliability, and efficiency of power supply while optimizing energy flow.

Energy consumption management in distribution transformers has also seen significant improvement with the application of microcontrollers. Traditional transformers experience a sharp decline in efficiency under low load conditions or during large load fluctuations. By introducing MCU-based energy optimization systems, transformers can dynamically adjust their operational states in real-time, reducing unnecessary energy consumption and improving overall grid system efficiency. Notably, through multi-objective optimization algorithms, microcontrollers not only enhance the adaptability of transformers under varying load conditions but also effectively reduce energy consumption in the grid.

This paper also emphasizes the integration of microcontrollers with renewable energy sources, providing a more flexible control mechanism for grid systems. With the widespread adoption of renewable energy, efficiently utilizing these volatile energy sources becomes a key challenge. Microcontrollers can effectively regulate energy flow to ensure grid stability and reliability.

Based on the research presented in this paper, future development directions for microcontrollers in energy-saving applications include:

(1) Enhancing Intelligent Control and Adaptive Capabilities

With the development of artificial intelligence technologies, microcontrollers will integrate smart algorithms like machine learning and deep learning to improve adaptive and optimization control capabilities. This will allow them to automatically adjust based on different scenarios and load demands, reducing unnecessary energy waste.

(2) Strengthening the Integration of Microcontrollers with the Internet of Things (IoT)

Microcontrollers will play a key role in the IoT by combining with intelligent sensors and actuators to enable real-time monitoring and remote control of devices. In the future, microcontrollers will be deeply integrated with IoT platforms to achieve large-scale device management, such as energy optimization in smart homes or smart cities.

(3) Improving Integration with Renewable Energy Systems

Microcontrollers can optimize control strategies to regulate renewable energy input and output, ensuring the stability of energy supply. When combined with smart grids, microcontrollers will effectively coordinate renewable and traditional energy sources to enhance grid efficiency.

(4) Strengthening Collaboration with Big Data and Cloud Computing

By integrating microcontrollers with big data and cloud computing platforms, precise management of devices and energy usage can be achieved. Through real-time data collection and analysis, microcontrollers can dynamically adjust device operating states and optimize energy management strategies.

(5) Promoting Applications in Agriculture and Industry

The energy-saving potential of microcontrollers in agriculture and industry remains to be further explored. In agriculture, intelligent irrigation systems, combined with sensors, can optimize water and energy usage. In industry, microcontrollers can monitor real-time energy consumption data from production lines, predict and schedule operations through algorithms, and improve production efficiency while reducing energy consumption.

(6) Continuously Optimizing Energy Storage and Scheduling

In the face of the challenges posed by the volatility of renewable energy, microcontrollers can optimize energy storage system charging and discharging management to ensure grid stability during load fluctuations. When combined with new energy storage technologies such as battery storage systems and supercapacitors, microcontrollers will better regulate power storage and usage patterns.

Through these development directions, microcontrollers will continue to play an important role in energy-saving and intelligent control fields. With technological advancements, the application of microcontrollers will become more widespread, particularly in areas such as smart homes, smart cities, and industrial energy conservation, where they hold immense potential.

Author Contributions: Conceptualization, Y.Y.; Methodology, B.W.; Software, Y.Y.; Validation, B.W. and H.H.; Investigation, Y.Y. and H.H.; Resources, Y.Y. and H.H.; Data curation, B.W. and H.H.; Writing—original draft, Y.Y.; Writing—review & editing, Y.Y., H.H. and B.W.; Supervision, Z.M. and H.H.; Project administration, Z.M. All authors have read and agreed to the published version of the manuscript.

Funding: This research received no external funding.

Data Availability Statement: The raw data supporting the conclusions of this article will be made available by the authors on request.

Conflicts of Interest: The authors declare no conflicts of interest.

Appendix A

Appendix A.1

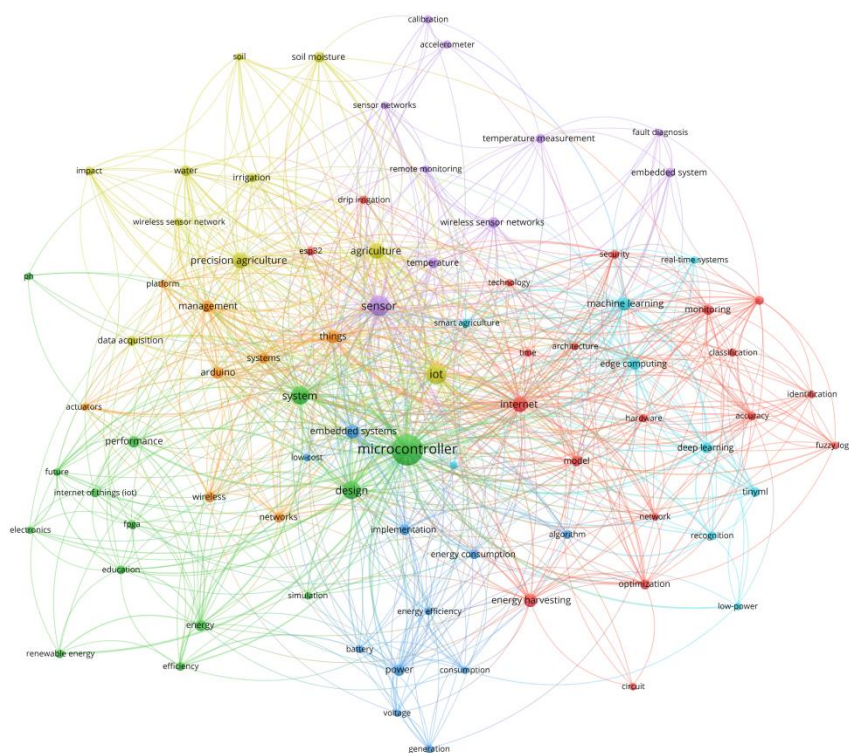

Figure A1. Analysis of keyword clustering network.

References

1. Ali, M., Koondhar, M. A., Ogale, J., Ali, A., & Khan, B. (2023). Intelligent hybrid energy system and grid integration using microcontrollers. *Computers & electrical engineering*, 110, 108873. doi: 10.1016/j.compeleceng.2023.108873
2. Ameer, S., Laghrouche, M., & Adane, A. (2001). Monitoring a greenhouse using a microcontroller-based meteorological data-acquisition system. *Renewable energy*, 24(1), 19-30. doi: 10.1016/S0960-1481(00)00181-6
3. Barkunan, S. R., Bhanumathi, V., & Sethuram, J. (2019). Smart sensor for automatic drip irrigation system for paddy cultivation. *Computers & electrical engineering*, 73, 180-193. doi: 10.1016/j.compeleceng.2018.11.013
4. Bolanakis, D. E. (2019). A Survey of Research in Microcontroller Education. *IEEE-RITA*, 14(2), 50-57. doi: 10.1109/RITA.2019.2922856
5. Demirtas, M., Sefa, I., Irmak, E., & Colak, I. (2008, 2008-1-1). Low-cost and high sensitive microcontroller based data acquisition system for renewable energy sources. Paper presented at the.

6. Guan, X., Lou, S., Li, H., & Tang, T. (2021). Intelligent control of quad-rotor aircrafts with a STM32 microcontroller using deep neural networks. *Industrial robot*, 48(5), 700-709. doi: 10.1108/IR-10-2020-0239
7. Kober, T., Schiffer, H., Densing, M., & Panos, E. (2020). Global Energy Perspectives to 2060 – WEC’s World Energy Scenarios 2019. *Energy strategy reviews*, 31, 100523. doi: 10.1016/j.esr.2020.100523
8. Lee, S., Sung, J., & Kwon, J. (2024). Optimizing RGB Convolution on Cortex-M7 MCU: Approaches for Performance Improvement. *IEEE access*, 12, 140594-140604. doi: 10.1109/ACCESS.2024.3439586
9. Marnerides, A. K., Smith, P., Schaeffer-Filho, A., & Mauthe, A. (2015). Power Consumption Profiling Using Energy Time-Frequency Distributions in Smart Grids. *IEEE communications letters*, 19(1), 46-49. doi: 10.1109/LCOMM.2014.2371035
10. Wu, H., Chen, C., & Weng, K. (2021). An Energy-Efficient Strategy for Microcontrollers. *Applied Sciences*, 11, 2581. doi: 10.3390/app11062581
11. Zhao, W., & Xia, F. (2006). An Efficient Approach to Energy Saving in Microcontrollers. *Advances in Computer Systems Architecture Lecture Notes in Computer Science*, 595-601. doi: 10.1007/11859802_63
12. Bournas, D. A. (2018). Concurrent seismic and energy retrofitting of RC and masonry building envelopes using inorganic textile-based composites combined with insulation materials: A new concept. *Composites. Part B, Engineering*, 148, 166-179. <https://doi.org/10.1016/j.compositesb.2018.05.032>
13. Elsts, A., & Mcconville, R. (2021). Are microcontrollers ready for deep learning-based human activity recognition? *Electronics*, 10(21), 2640. <https://doi.org/10.3390/electronics10212640>
14. Guan, X., Lou, S., Li, H., & Tang, T. (2021). Intelligent control of quad-rotor aircrafts with a STM32 microcontroller using deep neural networks. *Industrial Robot: The International Journal of Robotics Research and Application*, 48(5), 700-709. <https://doi.org/10.1108/IR-10-2020-0239>
15. Huang, J., Wang, S., Teng, F., & Feng, W. (2021). Thermal performance optimization of envelope in the energy-saving renovation of existing residential buildings. *Energy and Buildings*, 247, 111103. <https://doi.org/10.1016/j.enbuild.2021.111103>
16. Ilchev, S., Andreev, R., & Ilcheva, Z. (2021). Autonomous microcontroller system for sensor data gathering relying on solar-power and ultracapacitors. *Wireless Personal Communications*, 121(3), 2393-2405. <https://doi.org/10.1007/s11277-021-08115-1>
17. Jayakumar, H., Raha, A., & Raghunathan, V. (2017). Sleep-mode voltage scaling. *ACM Transactions on Embedded Computing Systems*, 16(1), 1-25. <https://doi.org/10.1145/3009394>
18. Jovanović, B., Damnjanović, M., Petković, P., & Litovski, V. (2015). Standard cell-based low power embedded controller design. *Journal of Circuits, Systems and Computers*, 24(06), 1550077. <https://doi.org/10.1142/S021812661550077X>
19. Krongtripop, T., & Kirdpipat, P. (2016a). Implementation of neural network based on the microcontroller for energy saving of electric kettle. *IEEE*, 1-4. <https://doi.org/10.1109/ICCE.2016.7432522>
20. Krongtripop, T., & Kirdpipat, P. (2016b). Implementation of neural network based on the microcontroller for energy saving of electric kettle. *IEEE*, 1-4. <https://doi.org/10.1109/ICCE.2016.7432522>
21. Lee, I., Sode, T., Loew, N., Tsugawa, W., Lowe, C. R., & Sode, K. (2017). Continuous operation of an ultra-low-power microcontroller using glucose as the sole energy source. *Biosensors and Bioelectronics*, 93, 335-339. <https://doi.org/10.1016/j.bios.2017.01.049>
22. Manimegalai, M., & Sebasthirani, K. (2022). An optimal model for power quality improvement in smart grid using gravitational search-based proportional integral controller and node microcontroller unit. *Electric Power Components and Systems*, 50. <https://doi.org/10.1080/15325008.2022.2136144>
23. Werulkar, A. S., & Kulkarni, P. S. (2014). Energy analysis of solar home lighting system with microcontroller-based charge controller. *Journal of Solar Energy Engineering*, 136(3). <https://doi.org/10.1115/1.4028151>
24. Wu, H., Chen, C., & Weng, K. (2021). An energy-efficient strategy for microcontrollers. *Applied Sciences*, 11(6), 2581. <https://doi.org/10.3390/app11062581>
25. Yu, J., Lukefahr, A., Das, R., & Mahlke, S. (2019). TF-Net. *ACM Transactions on Embedded Computing Systems*, 18(5s), 1-21. <https://doi.org/10.1145/3314238>
26. Zhang, X., Shen, J., Lu, Y., He, W., Xu, P., Zhao, X., Qiu, Z., Zhu, Z., Zhou, J., & Dong, X. (2015). Active solar thermal facades (ASTFs): From concept, application to research questions. *Renewable and Sustainable Energy Reviews*, 50, 32-63. <https://doi.org/10.1016/j.rser.2015.04.062>

27. Zhao, J. T., Ruan, J. H., He, Y., Guo, C. W., Jia, M. Y., & Yue, Z. T. (2024a). Design of automatic control system for distribution network transformers energy consumption based on single chip microcomputer. *Automation Application*, 65(24), 76-78.
28. Zhao, J. T., Ruan, J. H., He, Y., Guo, C. W., Jia, M. Y., & Yue, Z. T. (2024b). Design of automatic control system for distribution network transformers energy consumption based on single chip microcomputer. *Automation Application*, 65(24), 76-78.
29. Li, Z. W., Pan, J. J., & Zhang, J. B. (2006). Study on intelligent system of hyper-spectral data gathering based on wireless data communication technology in farm machinery. *Spectroscopy and Spectral Analysis*, 26(10), 1813-1816.
30. Rashid, Y., Rashid, A., Warraich, M. A., Sabir, S. S., & Waseem, A. (2019). Case Study Method: A Step-by-Step Guide for Business Researchers. *International Journal of Qualitative Methods*, 18, 322529470. doi: 10.1177/1609406919862424
31. Ameer, Laghrouche, & Adane (2001)
32. Saponara, S., Fanucci, L., & Terreni, P. (2007). Architectural-Level Power Optimization of Microcontroller Cores in Embedded Systems. *IEEE transactions on industrial electronics* (1982), 54(1), 680-683. doi: 10.1109/TIE.2006.885450
33. Cheour, R., Khriji, S., Abid, M., & Kanoun, O. (2020, 2020/1/1). Microcontrollers for IoT: Optimizations, Computing Paradigms, and Future Directions. Paper presented at the.
34. Ramasubramanian, M., Babu, T. R., Krishna, V. A., & Syed, K. (2021). Design of Intelligent Control and Monitoring System for Agriculture Based on Renewable Energy and IoT. *Journal of Physics Conference Series*, 1964, 42031. doi: 10.1088/1742-6596/1964/4/042031
35. Saha, S. S., Sandha, S. S., & Srivastava, M. (2022). Machine Learning for Microcontroller-Class Hardware: A Review. [Journal Article]. *IEEE Sens J*, 22(22), 21362-21390. doi: 10.1109/jsen.2022.3210773
36. Fang, X., Misra, S., Xue, G., & Yang, D. (2012). Smart Grid - The New and Improved Power Grid: A Survey. *IEEE Communications surveys and tutorials*, 14(4), 944-980. doi: 10.1109/SURV.2011.101911.00087
37. Kalkal, P., & Garg, V. K. (2017, 2017/1/1). Transition from conventional to modern grids: Modern grid include microgrid and smartgrid. Paper presented at the.
38. Mustapha, M., Mustafa, M. W., Khalid, S. N., Abubakar, I., & Shareef, H. (2015, 2015/1/1). Classification of electricity load forecasting based on the factors influencing the load consumption and methods used: An-overview. Paper presented at the.
39. Yao, X., Yi, B., Yu, Y., Fan, Y., & Zhu, L. (2020). Economic analysis of grid integration of variable solar and wind power with conventional power system. *Applied energy*, 264, 114706. doi: 10.1016/j.apenergy.2020.114706
40. A, E. S., & M, S. (2013). ENVIRONMENTAL AND HEALTH IMPACT OF COAL USE FOR ENERGY PRODUCTION. *Egyptian Journal of Occupational Medicine*, 37, 181-194. doi: 10.21608/ejom.2013.783
41. He, C., Zhang, X., Liu, T., Wu, L., & Shahidehpour, M. (2018). Coordination of Interdependent Electricity Grid and Natural Gas Network—a Review. *Current sustainable/renewable energy reports.*, 5(1), 23-36. doi: 10.1007/s40518-018-0093-9
42. Brunner, C., Deac, G., Braun, S., & Zöphel, C. (2020). The future need for flexibility and the impact of fluctuating renewable power generation. *Renewable energy*, 149, 1314-1324. doi: 10.1016/j.renene.2019.10.128
43. Liserre, M., Buticchi, G., Andresen, M., De Carne, G., Costa, L. F.,... Zou, Z. (2016). *The Smart Transformer: Impact on the Electric Grid and Technology Challenges* (10, pp. 46-58). New York: IEEE. (Reprinted).
44. Solomon, A. A., Kammen, D. M., & Callaway, D. (2014). The Role of Large-Scale Energy Storage Design and Dispatch in the Power Grid: A Study of Very High Grid Penetration of Variable Renewable Resources. *Applied Energy*, 134, 75-89. doi: 10.1016/j.apenergy.2014.07.095
45. Werbos, P. J. (2011). *Computational Intelligence for the Smart Grid—History, Challenges, and Opportunities* (6, pp. 14-21). Washington: IEEE. (Reprinted).
46. Prostejovsky, A. M., Brosinsky, C., Heussen, K., Westermann, D., Kreusel, J.,... Marinelli, M. (2019). The future role of human operators in highly automated electric power systems. *Electric power systems research*, 175, 105883. doi: 10.1016/j.epsr.2019.105883
47. Rana, M. M., Uddin, M., Sarkar, M. R., Meraj, S. T., Shafiullah, G. M., Muyeen, S. M.,... Jamal, T. (2023). Applications of Energy Storage Systems in Power Grids with and Without Renewable Energy Integration — A Comprehensive Review. *Journal of Energy Storage*, 68, 107811. doi: 10.1016/j.est.2023.107811

48. Gouveia, J., Moreira, C. L., & Peças Lopes, J. A. (2021). Influence of Load Dynamics on Converter-Dominated Isolated Power Systems. *Applied sciences*, 11(5), 2341. doi: 10.3390/app11052341
49. Zhao, C., He, J., Cheng, P., & Chen, J. (2017). Consensus-Based Energy Management in Smart Grid with Transmission Losses and Directed Communication. *IEEE Trans Smart Grid*, 8, 2049-2061. doi: 10.1109/tsg.2015.2513772
50. Ali, M., Koondhar, M. A., & Ali, A. (2023). Microcontroller-based renewable energy management systems for sustainable development. *Renewable Energy*, 181, 1054-1067. doi: 10.1016/j.renene.2021.09.033
51. Bhuiyan, M. S., & Ahmed, F. (2020). Energy-efficient microcontroller-based communication for smart grid applications. *Smart Grid*, 11(2), 348-357. doi: 10.1109/JSG.2019.2959176
52. Chen, L., & Liu, J. (2021). Optimization of low-power microcontroller-based IoT systems for smart home applications. *International Journal of Communication Systems*, 34(6), e4635. doi: 10.1002/dac.4635
53. Gómez, R., & Rodríguez, A. (2019). Design of an intelligent microcontroller-based system for energy-efficient buildings. *Automation in Construction*, 107, 102904. doi: 10.1016/j.autcon.2019.102904
54. Liao, Y., Liu, Q., & Li, X. (2022). Design of a low-cost microcontroller-based energy metering system for industrial applications. *Energy Reports*, 8, 2047-2054. doi: 10.1016/j.egy.2022.01.018
55. Mokhles, B., & Ghayesh, M. H. (2018). Smart energy management using microcontrollers in IoT-based applications. *Computers*, 7(3), 41-56. doi: 10.3390/computers7030041
56. Pandey, S., & Prakash, R. (2021). Energy optimization in microcontroller-based systems for industrial automation. *IEEE Transactions on Industrial Informatics*, 17(3), 2211-2219. doi: 10.1109/TII.2021.3078492
57. Rahman, M. M., & Hasan, M. (2020). Real-time monitoring and control system for renewable energy sources using microcontroller. *Renewable and Sustainable Energy Reviews*, 121, 109690. doi: 10.1016/j.rser.2020.109690
58. Suganthi, L., & Thangavel, P. (2022). Microcontroller-based energy-saving strategies for industrial motor control. *Energy*, 238, 121695. doi: 10.1016/j.energy.2021.121695
59. Wang, T., & Zhang, W. (2021). Design of an energy-efficient control system for microcontroller-based autonomous vehicles. *Journal of Electrical Engineering & Technology*, 16(5), 1947-1955. doi: 10.1007/s42835-021-00132-2
60. Xu, Y., & Zhang, X. (2020). A microcontroller-based approach for energy management in solar-powered buildings. *Solar Energy*, 207, 752-761. doi: 10.1016/j.solener.2020.07.021
61. Yadav, A., & Kumar, P. (2021). Microcontroller-based smart grid energy management system. *Energy Reports*, 7, 926-934. doi: 10.1016/j.egy.2021.02.022
62. Zhang, J., & Li, Y. (2019). Design of a microcontroller-based energy-efficient lighting system for smart homes. *Journal of Cleaner Production*, 221, 542-550. doi: 10.1016/j.jclepro.2019.02.121
63. Zhang, X., & Liu, Z. (2021). Design of an intelligent energy management system based on microcontrollers for smart cities. *Energy Procedia*, 168, 798-804. doi: 10.1016/j.egypro.2019.11.141.
64. Kumar, R., & Gupta, S. (2018). Real-time energy monitoring system for smart homes using IoT-based microcontroller. *International Journal of Energy Research*, 42(10), 3250-3260. doi: 10.1002/er.4018.
65. Park, S., & Kim, J. (2020). Smart home energy management system based on microcontroller and IoT technologies. *Renewable and Sustainable Energy Reviews*, 121, 109685. doi: 10.1016/j.rser.2020.109685.
66. Lyu, Q., & Zhang, P. (2022). Design of a low-cost IoT-enabled microcontroller-based system for energy-efficient HVAC control in smart buildings. *Building and Environment*, 211, 108675. doi: 10.1016/j.buildenv.2021.108675.
67. Patel, M., & Shah, S. (2021). IoT-enabled energy-efficient lighting system based on microcontroller for smart cities. *Sustainable Cities and Society*, 67, 102743. doi: 10.1016/j.scs.2021.102743.
68. Ahmed, S., & Rahman, A. (2021). Energy management and optimization in microcontroller-based renewable energy systems. *Energy Reports*, 7, 927-934. doi: 10.1016/j.egy.2021.01.015.

Disclaimer/Publisher's Note: The statements, opinions and data contained in all publications are solely those of the individual author(s) and contributor(s) and not of MDPI and/or the editor(s). MDPI and/or the editor(s) disclaim responsibility for any injury to people or property resulting from any ideas, methods, instructions or products referred to in the content.