

Cracking the Secret Code of the Selectivity Ratio between K^+ and Na^+ Ions in the KcsA K^+ channel

Yongwoon Jung^{1,*}

¹Department of Mathematics, Santa Fe College, 3000 NW 83rd Street, Gainesville, FL 32606, USA.

* Correspondence: yongwoon.jung@sfcollege.edu

ABSTRACT

The KcsA is a prokaryotic potassium-oriented channel, which is sourced from the *Streptomyces lividans* soil bacteria. From extensive studies that have been carried over the KcsA potassium channel, it has been proved that various factors enable the gating and shuttling of the potassium ions into and out of the cells. Some of the factors include; the different concentration of protons in the inside and outside membrane. The other factor is the existence of the selectivity filter equipped in the exit of channel pore, which enables the movement of the K^+ ions. Not only are potassium ions present in the channel but also sodium ions. Potassium and sodium ions are the ions that are essential in the conductivity of a cell because of their charge. An intuitive idea about why K^+ ions are at least 10,000 times more permeant than Na^+ ions is presented in various entities. The hypothesis is that the selectivity ratio is probably related to the successive entry of Na^+ ions, based on the premise that the ratio seems to be relevant to unpredictable quantities caused by Brownian corrosion of ions.

Keywords: KcsA K^+ channel; K^+ ion and Na^+ ion; Selectivity Filter; Snug-fit Mechanism; Selectivity Ratio; Brownian Dynamics

INTRODUCTION

10^6 K^+ ions pass through the K^+ channel every second, and this is caused by pH gating (opened at a strong acidic intracellular pH) (1); nevertheless, the selectivity filter of K^+ channel gates make K^+ ions 10,000 times more permeant than Na^+ ions as stated by (2). Based on the size preference (3), the channel shuttles a greater number of large particles compared to the number of smaller particles it shuttles ($K^+ > Rb^+ > NH_4^+ \gg Na^+ > Li^+$) (1). Many experimental and theoretical papers quantified or described the selectivity ratio between K^+ and Na^+ ions in the KcsA channel (2-16). No literature explains whether the selectivity ratio depends on the entry probability of Na^+ ions compared to that of K^+ ions. In this report, it is hypothesized that under the influence of Brownian dynamics (4), the selectivity margin could be related to the possibility of successive entry of Na^+ ions into the channel. Figure 1 shows how K^+ ions enter the K^+ channel and its transition from the inside of the cell to the outside of the cell. Here, the reverse flow direction of K^+ and Na^+ ions is excluded because their influx is expected to pass through the Na^+ channel or K^+ / Na^+ pump.

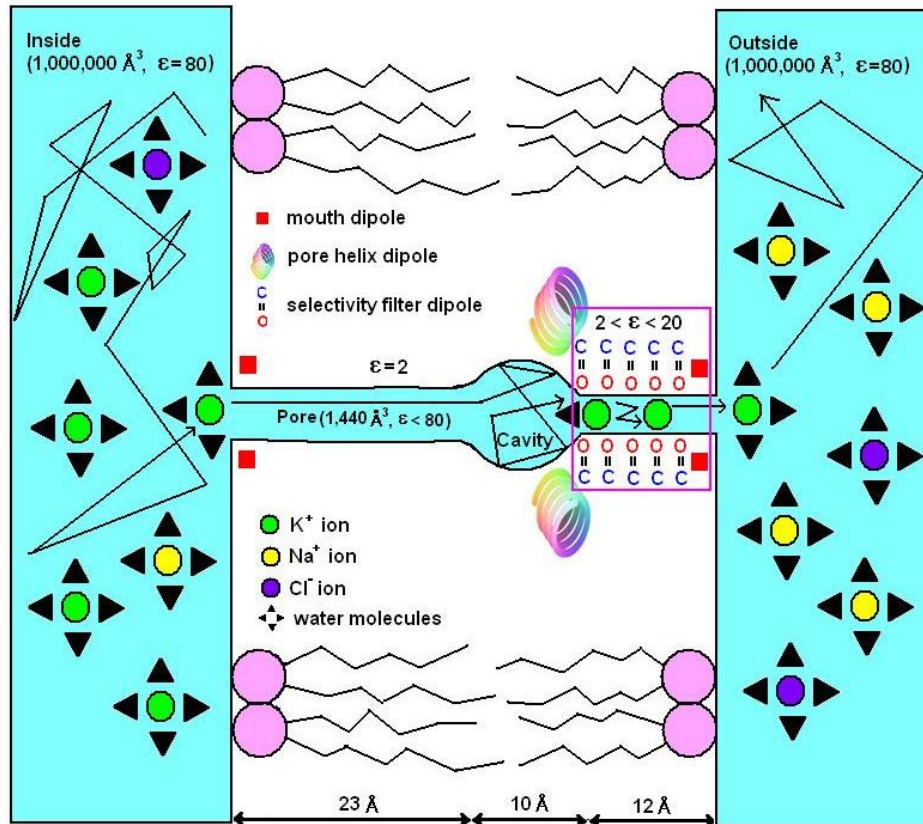

Fig. 1. The Schematic K^+ ion flow from the inside to the outside (17). This channel has a single-file-order system with a sizeable water-filled cavity in the center of it. The K^+ ions pass through the channel by the probable knock-on (18) and snug-fit mechanisms (3). There are three dipoles attracting cations; mouth dipoles attract cations, and so do pore helix dipoles, which help cations come in front of the selectivity filter immediately once cations enter the channel pore. The other one is the selectivity filter dipoles, which allow the K^+ ions and water molecules to pass through as it holds the Na^+ ions.

METHOD AND THEORY

The structure and the conductance (selectivity) mechanism of the bacterial potassium channel were discovered and proposed, respectively, by Rod Mackinnon (2). The channel is a single file circuit that allows only one ion to pass through it. The conductance of K^+ ions is presumed to follow the Knock-on mechanism, whereby: (1) It is presumed that two (or three)

water molecules separate the same number of K^+ ions at the selectivity filter of the channel; (2) the third K^+ ion enters the filter and pushes another K^+ ion to eventually let the rightmost K^+ ion escape from the filter by a sequence of successive K^+ -W collisions ($K^+ \Rightarrow K^+ \Rightarrow W \Rightarrow K^+ \Rightarrow W \Rightarrow K^+$); and (3) then the fourth K^+ ion comes to the filter and does the same process to help new rightmost K^+ ion escape from the filter. Remarkably, through this continuous repetition process, a million K^+ ions and less than 100 Na^+ ions leave the cell within a second until the inner cellular pH is 5 or 6, and once done, the channel gate gets closed. This conductance mechanism seems to be agreed on globally. On the other hand, the selectivity between K^+ and Na^+ ions is presumed to follow the Snug-fit mechanism, whereby: (1) It is presumed that larger K^+ ions are energetically well fitted to the oxygen atoms of water molecules than smaller Na^+ ions (3) and (2) the selectivity filter is lined by the carbonyl oxygen atoms, mimicking the water coordination (8) that favors to attract K^+ ions more than Na^+ ions. This snug-fit mechanism also seems to be agreed globally. However, there seems no firm agreement about the selectivity ratio mechanism about how K^+ channels exclusively isolate K^+ ions compared to that of Na^+ with a specific ratio of 10,000:1 (K^+ ions / Na^+ ions). This is the key question to be solved in this report and the potential answer is suggested with a hypothesis. The hypothesis is that the successive entry probability of Na^+ ions into the pore entrance will be a critical factor to determine the selectivity ratio. Figure 2 shows the distribution of K^+ and Na^+ ions in both the inside and outside of the cell. Considering the unique flow of the respective ions, the hitting probability of K^+ ion towards the pore entrance becomes 14-28 times greater than that of Na^+ ions under Brownian movement. That shows that the minimum entry probability of Na^+ ions is 1/15 compared to that of K^+ ions. Therefore, to calculate this selectivity ratio, the geometric sequence formula (Stifel, 1544) was used (19). That

is, the selectivity ratio $S_{\infty} = \sum_{n=1}^{\infty} ar^{n-1} = \frac{a}{1-r}$ ($-1 < r < 1$), where “ S_{∞} ” is a solution of this geometric sum, “ a ” is an initial value, and “ r ” is a common ratio.

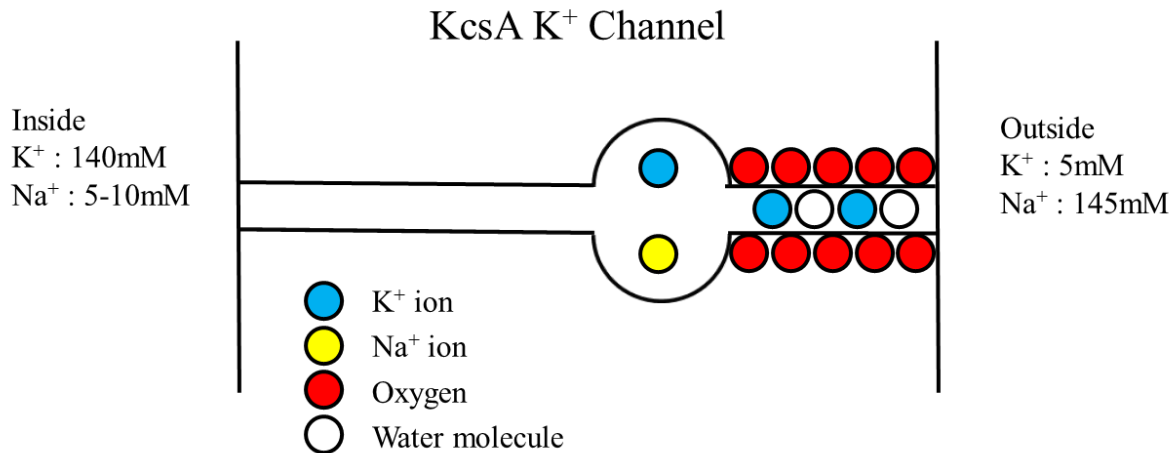

Fig. 2. The distribution of K⁺ and Na⁺ ions in the cell inside and outside.

RESULTS AND THEORETICAL PROOF

Figure 3 shows the six potential scenarios about what will happen if Na⁺ ions successively enter the channel. Assuming that the selectivity ratio of Na⁺ and K⁺ ions is 1/10,000 (minimum) and the entry probability of Na⁺ ions (compared to K⁺ ions) into the pore entrance is 1/15 (minimum), one Na⁺ ion always enter the channel whenever 14 K⁺ ions enter the channel. The successive entry probability of three Na⁺ ions is 1/3375, whereas that of four Na⁺ ions is 1/50625. It is presumed that at least four (occasionally two or three) Na⁺ ions should enter the channel successfully for the eventual exit of one Na⁺ ion. If this scenario works, then the possibility that Na⁺ ions pass through the filter is the sum of probability that more than four ions enter the channel. That is, (1) for the successive entry of more than three Na⁺ ion case (Fig. 3C), probability =

$\lim_{n \rightarrow \infty} \left[\left(\frac{1}{15}\right)^3 + \left(\frac{1}{15}\right)^4 + \dots + \left(\frac{1}{15}\right)^{n-1} + \left(\frac{1}{15}\right)^n \right] = 1/3150$, whereas (2) for the successive entry of

more than four Na^+ ion case (Fig. 3D-F), probability = $\lim_{n \rightarrow \infty} \left[\left(\frac{1}{15}\right)^4 + \left(\frac{1}{15}\right)^5 + \dots + \left(\frac{1}{15}\right)^{n-1} + \left(\frac{1}{15}\right)^n \right] = 1/47250$. So, the potential exit case of Na^+ ion would lie between stance (1) and (2). There is no theoretical evidence supporting or disapproving this suspectable Brownian output. However, this intuitive scenario could be the master key, partially cracking the secret code of the selectivity ratio (at least 1/10,000) between K^+ and Na^+ ions. Figure 3D-F shows that the channel will not resist pushing out the Na^+ ions when more than four Na^+ ions enter the channel successively, though the detailed dynamics remains uncertain. On the other hand, when there are less than four Na^+ ions in the cavity, there are higher chances that they will go back to the inside cell without exiting.

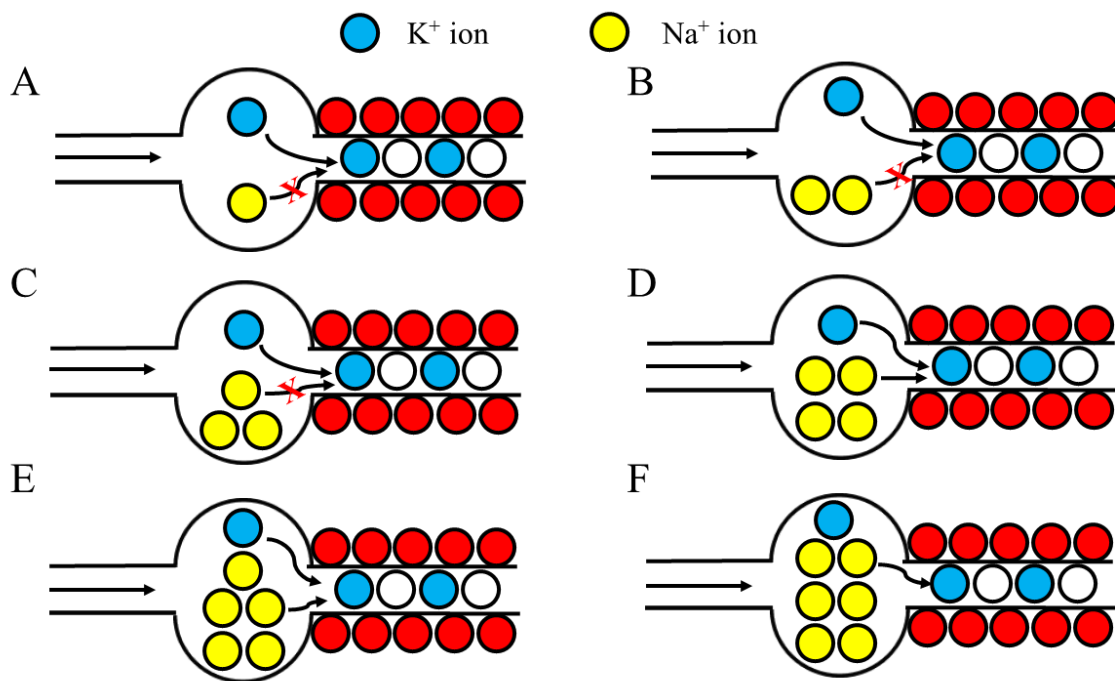

Fig. 3. The hypothetical cases that Na^+ ions pass through the selectivity filter. Figure B or C also could be added to those Na^+ ion exit cases when various selectivity ratios are reported.

DISCUSSION

By this line of simple reasoning, it is evidenced that the entry probability of Na⁺ ion is approximately 1/15, while that of K⁺ ion is roughly 14/15. However, there was no trial of theoretical proof on what happens in the behaviors of K⁺ and Na⁺ ions in the cavity and the selectivity filter or no snap photos available that would vividly exhibit such scenario in the cavity and the selectivity filter. However, there are only two scenarios in defining this event: (1) The successive entry of Na⁺ ions is not relevant to the selectivity 1/10,000 and (2) The successive entry of Na⁺ ions is more or less related to the selectivity 1/10,000. If the former assumption is valid, then, regardless of the mixture content of K⁺ and Na⁺ ions in the cavity, the selectivity ratio only depends on the structure of the selectivity filter and the chemistry between the atoms of the channel proteins and relevant two cations. In this case, even a single K⁺ ion in the cavity can cross the selectivity filter and escape the channel by unexpected events of random Brownian movement that is theoretically not quantified. On the other hand, if the latter assumption is valid, as a higher concentration of Na⁺ ions reside in the intercellular cell and the cavity, so increases the Na⁺ ion selectivity ratio. When a simulator with more exquisite testing equipment is developed, this secret code of selectivity ratio will be quickly exposed in public.

REFERENCES AND NOTES

1. Cuello et al., *Biochemistry* **37**, 3229-3236 (1998).
2. Doyle et al., *Science* **280**, 69-77 (1998).
3. Benzanilla et al., *J Gen Physiol.* **60**, 588-608 (1972).
4. Chung et al., *Biophys J.* **77**, 2517-2533 (1999).

5. Aqvist et al., *Nature* **404**, 881-884 (2000).
6. Berneche et al., *Nature* **414**, 73-77 (2001).
7. Morais-Cabral et al., *Nature* **414**, 37-42 (2001).
8. Zhou, Yufeng, et al., *Nature* **414**, 43-48 (2001).
9. Shrivastava et al., *Biophys J.* **83**, 633-645 (2002).
10. Nimigean et al., *J Gen Physiol.* **120**, 323-335 (2002).
11. Noskov et al., *Nature* **431**, 830-834 (2004).
12. Varma et al., *J Mol Biol.* **376**, 13-22 (2008).
13. Thompson et al., *Nature Structural & Molecular Biology* **16**, 1317-1324 (2009).
14. Roux et al., *Essays in biochemistry* **61**, 201-209 (2017).
15. Corry et al., *Nature Chemistry* **10**, 799-800 (2018).
16. Tilegenova et al., *PNAS* **116**, 16829-16834 (2019).
17. Jung et al., *J. Chem. Phys* **131**, 215101 (1-10) (2009).
18. Kopec et al. , *Nature Chemistry* **10**, 813-820 (2018).
19. Stifel, Michael. *Arithmetica Integra.* (1544).

ACKNOWLEDGMENTS

The author is grateful to Shin-Ho Chung and Clay Armstrong for their helpful comments.