

Technical Note

Not peer-reviewed version

Fully Analog Spintronic Crossbar Control for Rapid PV Mismatch Management and Maximum-Power Tracking

[Pietro Perlo](#)*

Posted Date: 16 April 2026

doi: 10.20944/preprints202604.1213.v1

Keywords: spintronic crossbar; photovoltaic systems; partial shading; rapid shading; analog MPPT; bypass protection; mismatch management; magnetic tunnel junction; PWM control; energy harvesting; converter dynamics; decision latency



Preprints.org is a free multidisciplinary platform providing preprint service that is dedicated to making early versions of research outputs permanently available and citable. Preprints posted at Preprints.org appear in Web of Science, Crossref, Google Scholar, Scilit, Europe PMC.

Copyright: This open access article is published under a [Creative Commons CC BY 4.0 license](#), which permit the free download, distribution, and reuse, provided that the author and preprint are cited in any reuse.

Disclaimer/Publisher's Note: The statements, opinions, and data contained in all publications are solely those of the individual author(s) and contributor(s) and not of MDPI and/or the editor(s). MDPI and/or the editor(s) disclaim responsibility for any injury to people or property resulting from any ideas, methods, instructions, or products referred to in the content.

Technical Note

Fully Analog Spintronic Crossbar Control for Rapid PV Mismatch Management and Maximum-Power Tracking

Pietro Perlo

Interactive Fully Electrical VehicleS (IFEVS), 10040 La Loggia, Italy; pietro.perlo@ifevs.com

Abstract

This technical note discusses, at system level, a fully analog control architecture in which a programmable spintronic crossbar can generate rapid mismatch-handling signals and a maximum-power-control signal for a photovoltaic source operating under rapidly varying shading conditions. The note is intentionally technology-agnostic and focuses on architectural principles rather than on fabrication details, device-specific programming workflows, or implementation-specific optimization procedures. The main value of the approach is the possibility of forming protection and control signals in parallel, with very low decision latency in the fast path, while overall operating-point convergence remains governed by the source and converter dynamics. The discussion is framed as a pedagogical technical note associated with already filed patent applications. Its purpose is to explain the conceptual role of a spintronic crossbar in analog control, the relationship between crossbar decision latency and converter response time, and the practical distinction between system-level architectural advantage and device-level maturity.

Keywords: spintronic crossbar; photovoltaic systems; partial shading; rapid shading; analog MPPT; bypass protection; mismatch management; magnetic tunnel junction; PWM control; energy harvesting; converter dynamics; decision latency

1. Introduction

Fast partial shading is one of the main reasons photovoltaic systems underperform in real environments such as urban corridors, trees, buildings, poles, and moving vehicles. In a conventional implementation, a digital controller measures electrical variables, computes a control action, and updates the converter over a finite time base. This architecture is flexible and well established, but it introduces sequential sensing and computation in the control path.

The system-level idea considered here is different: a programmable spintronic crossbar is treated as a non-volatile analog fabric capable of forming multiple control-related outputs in parallel. In the context of a pedagogical four-cell PV string, the crossbar can be used to produce signals associated with bypass handling and with converter command generation from the same set of cell-related inputs. The note does not assume a specific commercial crossbar product or a single device technology route; rather, it explains the architectural concept in a way that remains valid across different MTJ-based implementations.

The emphasis is therefore on architecture, not on a specific engineering recipe. The purpose is to explain why such an approach may be attractive for rapidly varying mismatch conditions, especially when the dominant need is to reduce decision latency in the protection path.

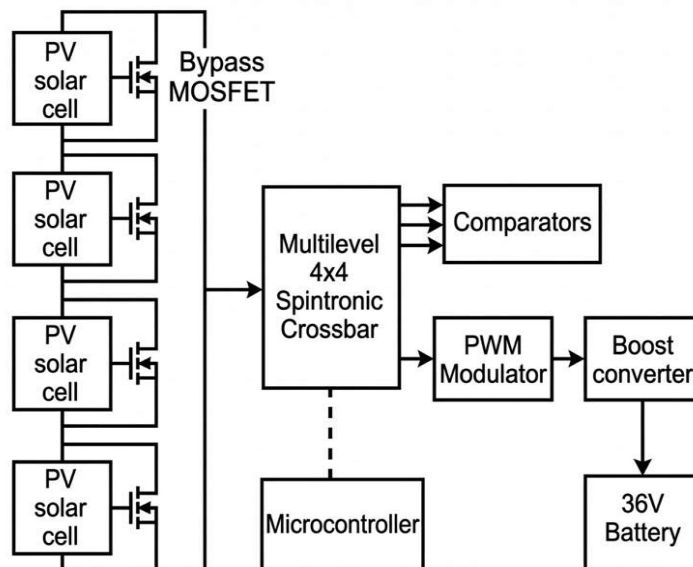

Figure 1. System-level conceptual block diagram of a fully analog spintronic-crossbar control architecture for a pedagogical four-cell PV string. The crossbar generates parallel analog outputs associated with bypass handling and power-control signaling, while an optional supervisor may be used only for configuration or health monitoring.

2. Architectural Principle

At the architectural level, the crossbar receives row inputs derived from source variables, for example per-cell voltages and, where appropriate, selected string-level signals. Its column outputs are analog weighted sums. After current-to-voltage conversion or equivalent readout, different outputs may be routed to comparator-based protection stages, to analog PWM-related stages, or to other supervisory analog blocks.

This note deliberately avoids prescribing a unique resource-allocation rule for a specific crossbar size. In a small pedagogical array, the available columns may be partitioned in several reasonable ways depending on the desired balance between mismatch detection, converter actuation, and supervisory functions. The important architectural point is that one programmable analog fabric can support more than one control role at the same time.

A small demonstrator is useful for explanation, but the same principle is not inherently tied to a four-cell example. The concept is more general: cell- or substring-related signals can be mapped to a programmable conductance matrix, and the resulting analog outputs can be interpreted by downstream interface circuits according to the needs of the application.

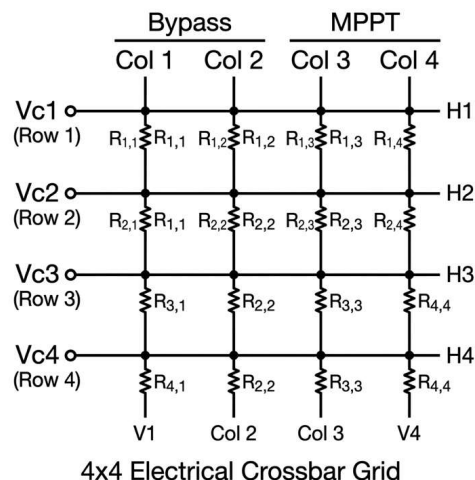

Figure 2. Example conceptual allocation of row and column resources in a small pedagogical crossbar. The diagram is illustrative only and should not be interpreted as prescribing a unique hardware partitioning.

3. Spintronic Crossbar at System Level

A spintronic crossbar is an array of programmable conductance elements, typically based on magnetic tunnel junctions, placed at the intersections of rows and columns. When voltages are applied to the rows, the column currents correspond to weighted sums of those inputs. At system level this is usefully described as an analog matrix-vector multiplication performed in parallel.

For the purposes of this note, two device categories are relevant. Binary devices provide two stable conductance states and are the most mature from an industrial point of view. Multilevel devices provide more than two stable conductance states and can in principle support finer analog mappings. The note remains technology-agnostic: the architectural advantages discussed here do not depend on one exact device stack, one exact switching mechanism, or one exact fabrication route.

In practical terms, multilevel operation should be understood as an enabling possibility rather than as a requirement for every implementation. Even when the underlying device precision is modest, a crossbar-based architecture can still be informative for rapid analog mismatch handling and for qualitative control-signal generation.

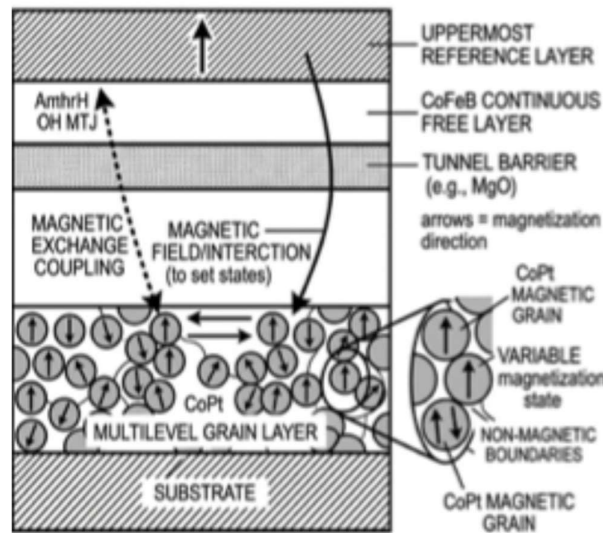

Figure 3. Illustrative multilevel MTJ concept used only to explain the possibility of more than two stable conductance states. The note remains technology-agnostic and does not depend on a specific device stack or fabrication route.

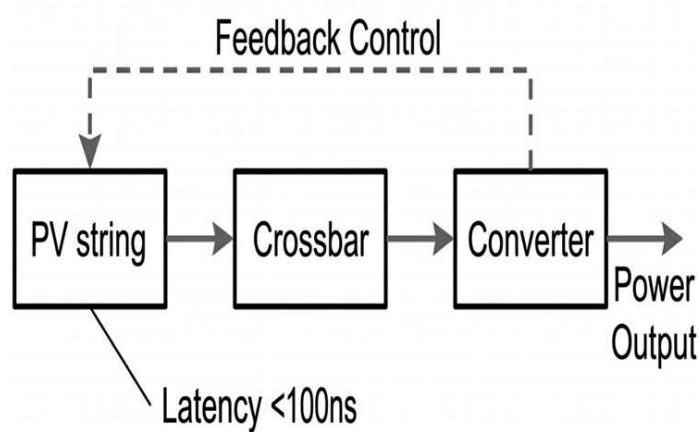

Figure 4. Qualitative feedback interpretation: the crossbar can reduce decision latency, while the converter and source dynamics still determine the settling of the operating point.

4. Parallel Protection and Power-Control Functions

A useful way to interpret the crossbar in this application is as a common analog front-end capable of producing more than one class of control signal in parallel. One class of output can be associated with rapid mismatch handling, for example comparator-based activation of bypass or isolation stages when a local source element deviates significantly from the expected operating region. A second class of output can be associated with converter actuation, for example by providing an analog signal that is translated into PWM behavior by a downstream interface stage.

This parallelism is important conceptually. In a conventional sequential digital architecture, sensing and computation happen in ordered steps. In a crossbar-centered architecture, the weighted-sum operation itself is simultaneous across columns, so multiple control-related signals can be formed at the same time. This does not mean that the power stage itself changes instantly; it means that the decision-forming part of the loop can be made extremely fast and highly parallel.

Under partial shading, the power-voltage characteristic can exhibit more than one local maximum. For that reason, a practical system may still benefit from occasional higher-level supervision or a broader operating-point check, even when the fast protection and local analog control functions are handled in parallel. That supervisory layer may be implemented in different ways and need not reside in the high-speed path.

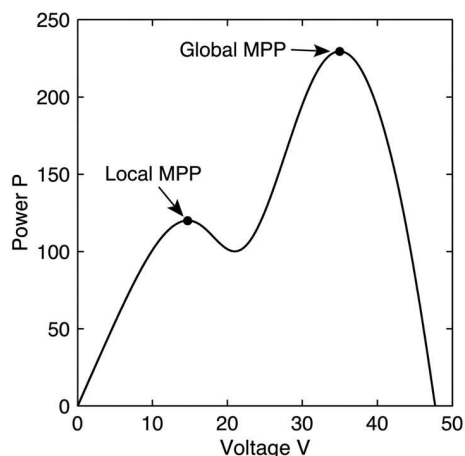

Figure 5. Under partial shading, multiple local power maxima may exist. Practical systems may therefore benefit from occasional higher-level supervision in addition to fast analog response in the protection path.

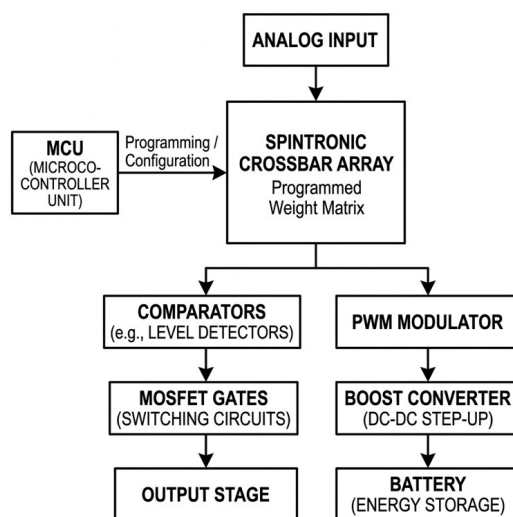

Figure 6. Qualitative signal-flow view of a crossbar-assisted control chain. The figure highlights the architectural roles of analog input, analog decision generation, comparator-based protection, and PWM-based converter actuation.

5. Timing Interpretation

The most important timing distinction in this architecture is the difference between decision latency and plant response. The crossbar can form analog outputs very quickly, and downstream comparator or PWM-interface stages can act on those outputs with little additional delay. However, the source and converter still evolve according to electrical time constants, switching cycles, control bandwidth, filtering, and any current or safety limits in the system.

For that reason, the chief practical benefit should be described carefully: the architecture can reduce the time needed to form protection- and control-related signals in the fast path, especially

during abrupt mismatch events. It should not be described as making the power stage itself instantaneous. A well-phrased system-level claim is therefore “faster decision formation,” not “instantaneous energy recovery.”

This distinction also helps keep the note educational and technically balanced. The architectural promise lies in removing or reducing sequential digital delay where that delay matters most, while leaving room for the reality that converters and sources obey their own dynamics.

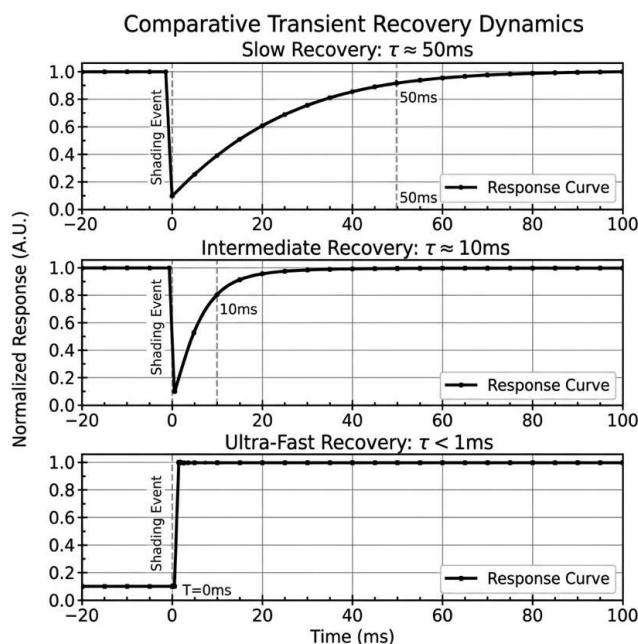

Figure 7. Qualitative timing comparison. The key architectural benefit is faster decision formation in the protection/control path; the actual power-stage convergence remains governed by converter bandwidth and system dynamics.

6. Present Scope and Practical Limits

This technical note is intentionally conservative in what it claims. It does not attempt to define a unique implementation path, to specify a full calibration strategy, or to claim a particular device-resolution threshold as necessary for utility. Instead, it frames the crossbar approach as an architectural direction whose usefulness depends on the maturity of the underlying devices, the interface electronics, and the requirements of the photovoltaic application.

Several practical limits remain important. Device variability, temperature dependence, readout noise, and analog-interface linearity all influence how accurately an analog control law can be represented in hardware. Likewise, partial shading can create multiple local operating regions, which means that practical systems may combine rapid analog response with occasional slower supervisory actions. None of these realities invalidates the architectural idea; they simply define its engineering context.

This is why the note is best read as a system-level companion to the broader patent and technical discussion: it explains why a fully analog spintronic-crossbar control concept is attractive, but it does not attempt to disclose the detailed implementation space exhaustively.

7. Conclusion

A fully analog spintronic-crossbar architecture is an interesting candidate for rapid photovoltaic mismatch management and maximum-power-related control because it allows multiple analog outputs to be formed in parallel from a programmable conductance fabric. In rapidly varying

conditions, such an architecture can reduce decision latency in the fast path while remaining compatible with the slower dynamics of converters and sources.

The value of the concept lies in its architectural separation between fast analog signal formation and the broader system dynamics that ultimately govern operating-point convergence. Framed in this way, the approach can be discussed safely and usefully as an educational technical note associated with already filed patent material, without disclosing fabrication recipes, exact programming workflows, or implementation-specific optimization strategies.

Acknowledgements: Supported by EIC Pathfinder MultiSpin.AI, grant no. 101130046, by HORIZON-JU-Chips-2025-1-IA NeAIxt grant no. 101194172 and by HORIZON-JU-Chips-2023-1-IA EdgeAI-Trust grant no. 101139892.

Conflict of Interest: The author is affiliated with Interactive Fully Electrical VehicleS (IFEVS). This technical note is associated with patent applications already filed in Italy. It is presented for educational and scientific discussion at system level. This technical note is intentionally written at system level and for educational purposes. It does not disclose fabrication recipes, device-stack selections, calibration workflows, program-and-verify procedures, economic projections, or implementation-specific optimization details beyond what is necessary to explain the architectural concept.

Table of Acronyms

Acronym	Meaning	Acronym	Meaning
ADC	Analog-to-Digital Converter	MTJ	Magnetic Tunnel Junction
DC-DC	Direct Current to Direct Current	MCU	Microcontroller Unit
IMC	In-Memory Computing	MVM	Matrix-Vector Multiplication
MPPT	Maximum Power Point Tracking	PV	Photovoltaic
PWM	Pulse-Width Modulation	TIA	Transimpedance Amplifier
STT	Spin-Transfer Torque	SOT	Spin-Orbit Torque
MRAM	Magnetoresistive Random-Access Memory	TMR	Tunnel Magnetoresistance

References

- Grollier J, Querlioz D, Camsari KY, Everschor-Sitte K, Fukami S, Stiles MD. Neuromorphic spintronics. *Nat Electron*. 2020;3(7):360-370. doi:10.1038/s41928-019-0360-9.
- Markovic D, Mizrahi A, Querlioz D, Grollier J. Physics for neuromorphic computing. *Nat Rev Phys*. 2020;2(9):499-510. doi:10.1038/s42254-020-0208-2.
- Jung S, Lee H, Myung S, Kim H, Yoon SK, Kwon SW, Ju Y, Kim M, Yi W, Han S, Kwon B, Seo B, Lee K, Koh GH, Lee K, Song Y, Choi C, Ham D, Kim SJ. A crossbar array of magnetoresistive memory devices for in-memory computing. *Nature*. 2022;601(7892):211-216. doi:10.1038/s41586-021-04196-6.
- Lv Y, Zink BR, Bloom RP, Cilasun H, Khanal P, Resch S, Chowdhury Z, Habiboglu A, Wang W, Sapatnekar SS, Karpuzcu U, Wang JP. Experimental demonstration of magnetic tunnel junction-based computational random-access memory. *npj Unconv Comput*. 2024;1:3. doi:10.1038/s44335-024-00003-3.
- Shao Q, Wang Z, Zhou Y, Fukami S, Querlioz D, Chen Y, Chua LO. Spintronic memristors for computing. *npj Spintronics*. 2025;3:16. doi:10.1038/s44306-025-00078-z.
- Gupte KK, Mugdho SS, Huang C, Yu S, Wang C. Scalable and robust multi-bit spintronic synapses for analog in-memory computing. *npj Unconv Comput*. 2026;3:8. doi:10.1038/s44335-026-00055-7.
- Deng Y, Li W, Lan X, Zhang E, Li R, Shang Y, Liu S, Li B, Liu X, Zheng H, et al. Field-free switching of spin crossbar arrays by asymmetric spin current gradient. *Adv Funct Mater*. 2024;34:2307612. doi:10.1002/adfm.202307612.
- Esram T, Chapman PL. Comparison of photovoltaic array maximum power point tracking techniques. *IEEE Trans Energy Convers*. 2007;22(2):439-449. doi:10.1109/TEC.2006.874230.
- Patel H, Agarwal V. Maximum power point tracking scheme for PV systems operating under partially shaded conditions. *IEEE Trans Ind Electron*. 2008;55(4):1689-1698. doi:10.1109/TIE.2008.917118.
- Vieira RG, de Araujo FMU, Dhinish M, Guerra MIS. A comprehensive review on bypass diode application on photovoltaic modules. *Energies*. 2020;13(10):2472. doi:10.3390/en13102472.

11. Bauwens P, Doutreloigne J. Reducing partial shading power loss with an integrated Smart Bypass. Sol Energy. 2014;103:134-142. doi:10.1016/j.solener.2014.01.040.

Disclaimer/Publisher's Note: The statements, opinions and data contained in all publications are solely those of the individual author(s) and contributor(s) and not of MDPI and/or the editor(s). MDPI and/or the editor(s) disclaim responsibility for any injury to people or property resulting from any ideas, methods, instructions or products referred to in the content.