

Article

Not peer-reviewed version

---

# Structural Barriers, Community Disempowerment, and the Paradox of Local Support: Evidence from Ankasa Conservation Area, Ghana

---

[George Tandoh](#)<sup>\*</sup> and Nicholas Imbeah

Posted Date: 29 September 2025

doi: 10.20944/preprints202509.2323.v1

Keywords: community-based tourism (CBT); structural barriers; community disempowerment; local support; conservation areas; Ghana



Preprints.org is a free multidisciplinary platform providing preprint service that is dedicated to making early versions of research outputs permanently available and citable. Preprints posted at Preprints.org appear in Web of Science, Crossref, Google Scholar, Scilit, Europe PMC.

Copyright: This open access article is published under a Creative Commons CC BY 4.0 license, which permit the free download, distribution, and reuse, provided that the author and preprint are cited in any reuse.

Disclaimer/Publisher's Note: The statements, opinions, and data contained in all publications are solely those of the individual author(s) and contributor(s) and not of MDPI and/or the editor(s). MDPI and/or the editor(s) disclaim responsibility for any injury to people or property resulting from any ideas, methods, instructions, or products referred to in the content.

Article

# Structural Barriers, Community Disempowerment, and the Paradox of Local Support: Evidence from Ankasa Conservation Area, Ghana

George Tandoh <sup>1,\*</sup> and Nicholas Imbeah <sup>2</sup>

<sup>1</sup> Department of Geography and Resource Development, University of Ghana, Legon, Accra, Ghana

<sup>2</sup> Department of Tourism Management, Takoradi Technical University, P. O. Box 256, Takoradi, Ghana

\* Correspondence: tandohgeorge@gmail.com; Tel.: +233501848447

## Abstract

Community-based tourism (CBT) is promoted as a sustainable development strategy, yet implementation often fails to empower local communities. This study examines how structural barriers (Bar) shape community disempowerment (Dsemp) and local support (Lcst) for tourism development in the Ankasa Conservation Area (ACA), Ghana. A cross-sectional survey of 205 residents from three adjacent communities was conducted using validated scales measuring structural barriers, disempowerment, and reduced local support. Data were analyzed through structural equation modeling with maximum likelihood (ML) estimation. The measurement model showed strong reliability and validity, and the structural model achieved excellent fit ( $\chi^2(42) = 46.315$ ,  $p = 0.299$ ; RMSEA = 0.022; CFI = 0.995; TLI = 0.993). Structural barriers significantly predicted community disempowerment ( $\beta = 0.192$ ,  $p = 0.015$ ). However, disempowerment did not significantly reduce local support for tourism ( $\beta = 0.058$ ,  $p = 0.480$ ). Despite limited benefits, residents maintained support for tourism. Findings challenge linear assumptions in Social Exchange Theory (SET), suggesting resilience and future expectations underpinning support despite disempowerment. Addressing governance deficiencies, elite capture, and economic barriers is critical for fostering community empowerment and sustainable tourism development.

**Keywords:** community-based tourism (CBT); structural barriers; community disempowerment; local support; conservation areas; Ghana

## 1. Introduction

Community-based tourism (CBT) is widely promoted as a strategy for rural sustainable development [1,2,42], particularly in Sub-Saharan Africa, where it promises poverty reduction, environmental conservation, and community empowerment [3,4]. However, despite its theoretical appeal, CBT has often failed to meet expectations [5–8]. In practice, especially in conservation areas, communities face governance complexities, external control, and limited benefits, leading to persistent challenges that conventional CBT models struggle to navigate effectively [9,10,52].

Central to these implementation challenges is the persistent problem of community disempowerment, a process whereby local residents are systematically excluded from meaningful participation in tourism planning, management, and benefit-sharing arrangements [11,12,44,54]. This disempowerment manifests through various mechanisms including opaque governance structures that privilege external stakeholders, elite capture processes that concentrate benefits among socially and economically advantaged community members, and structural economic limitations that constrain communities' ability to participate effectively in tourism value chains [2,13,14]. Understanding the relationship between structural barriers, community disempowerment, and local support for tourism development has become increasingly critical as tourism continues to expand in environmentally sensitive areas across the Global South. Local community support represents a

fundamental prerequisite for sustainable tourism development, providing the social license necessary for tourism operations while contributing to conservation outcomes and visitor experiences [24,35]. Yet the mechanisms through which structural impediments influence community attitudes and behaviors toward tourism remain poorly understood, both theoretically and empirically. In Africa, conservation tourism combines biodiversity protection with rural development [9,15] but remains shaped by colonial legacies, external dominance, and power imbalances that limit local benefits [3,16–18,48]. Ghana represents a particularly interesting case for examining community-based tourism challenges and opportunities in West Africa because while it has strong tourism potential and supportive policies, community participation in CBT remains constrained by weak institutions, elite capture, and implementation gaps [8,19,20,46,53]. The Ankasa Conservation Area exemplifies these challenges, where communities continue to experience minimal involvement and benefits despite various attempts to develop community-based ecotourism initiatives [2,8,14,19,20]. Despite the promise of community-based tourism (CBT), a persistent gap exists between theory and practice, particularly in protected areas where structural barriers undermine empowerment and weaken local support. While disempowerment in tourism contexts is well-documented, limited research explains how structural barriers create disempowerment and shape community attitudes [27,34]. Most studies examine these issues in isolation, leading to fragmented understanding [37]. This gap is significant both theoretically and practically. Theoretically, it restricts the development of frameworks that capture barrier–disempowerment–support relationships. Practically, it limits the effectiveness of interventions, which often address symptoms rather than root causes [1,66]. In Africa, where CBT receives major investment, evidence-based approaches are urgently needed. Moreover, existing frameworks such as social exchange theory and stakeholder theory remain inadequate, as they overlook power imbalances and governance failures central to community responses [5,27]. This study seeks to address identified research gaps by systematically examining how structural barriers lead to community disempowerment and reduced local support, guided by three research questions: (a) What is the relationship between structural barriers and community disempowerment? (b) How does disempowerment influence local support for tourism? (c) What mechanisms connect structural barriers to disempowerment? The study contributes to the community-based tourism literature and to broader understanding of sustainable tourism development in conservation contexts by providing validated instruments to measure barriers, disempowerment, and support. The study tests and refines existing frameworks for understanding community responses to tourism development. Also, the research provides context-specific insights into community-based tourism challenges in West African conservation areas, contributing to the limited but growing literature on African tourism development. Furthermore, the study's findings have practical implications for tourism policy and development practice, providing evidence-based guidance for addressing structural barriers to community empowerment and enhancing the sustainability of conservation tourism initiatives.

## 2. Literature Review, Conceptual Model and Hypotheses Development

### 2.1. Structural Barriers in Community-Based Tourism

Research consistently identifies three categories of structural barriers that constrain meaningful community participation in tourism development [3,4,20]. In Ghana, these patterns often replicate colonial-era extractive structures where benefits flow upward while costs remain localized [5,46]. Studies across Kenya's conservancies similarly document how governance failures create "participation fatigue" among communities [6].

Elite capture represents a second critical barrier [7,8,62]. Research in East African conservation areas demonstrates how tourism benefits consistently flow to educated elites and traditional leaders while marginalized groups remain excluded [9]. In conservation areas in Ghana, poor infrastructure, limited financial services, and inadequate skills constrain communities' ability to participate meaningfully in tourism value chains [10,11,53,56].

## 2.2. Community Disempowerment and Local Support

The relationship between disempowerment and local support represents an underexplored dimension of sustainable tourism. Early research assumed direct relationships between negative experiences and declining support [14,15] but contemporary evidence reveals more complex patterns. In African conservation contexts, communities often maintain support despite experiencing clear costs, driven by limited alternatives and hope for future benefits [16,17].

Research in tourism communities in Ghana found that despite widespread dissatisfaction with governance and benefit distribution, support for tourism development remained high due to perceived future potential [5]. Similar findings across West Africa reveal communities distinguish between support for tourism as a concept versus satisfaction with current implementation [18]. However, empirical research specifically examining how disempowerment processes influence support remains scarce, particularly in conservation settings.

Social Exchange Theory (SET) has dominated understanding of community attitudes toward tourism but shows significant limitations in explaining responses where communities support tourism despite experiencing net costs [19,20]. Studies in African conservation contexts provide compelling evidence that communities maintain support even when experiencing resource access restrictions and minimal economic benefits, challenging SET's cost-benefit assumptions [16,17].

Stakeholder theory offers alternative insights emphasizing relationships and governance processes, but empirical applications at the community level remain limited [21,22]. Integration of these frameworks with empowerment literature may yield more robust understanding of community responses in power-laden contexts.

This review identifies four critical gaps: (1) limited systematic research examining the full pathway from barriers through disempowerment to support outcomes; (2) methodological reliance on qualitative approaches that cannot test theoretical relationships empirically; (3) insufficient research in African conservation tourism contexts despite their global significance; and (4) theoretical frameworks inadequate for explaining community responses in contexts of significant power imbalances. The present study addresses these gaps through quantitative investigation of barrier-disempowerment-support relationships in Ankasa Conservation Area in Ghana.

## 2.3. Conceptual Model and Hypotheses Development

The conceptual framework integrates three complementary theories. Empowerment, Social exchange and Stakeholder theories. The framework posits a sequential relationship whereby structural barriers create community disempowerment, which influences local support for tourism development. This model moves beyond simple cost-benefit explanations to examine how structural impediments systematically constrain community agency. Based on the framework below, two hypotheses were developed and tested in the study:

**Hypothesis 1.** *Structural barriers have a positive effect on community disempowerment.*

**Hypothesis 2.** *Community disempowerment has a positive effect on reduced local support for sustainable tourism.*

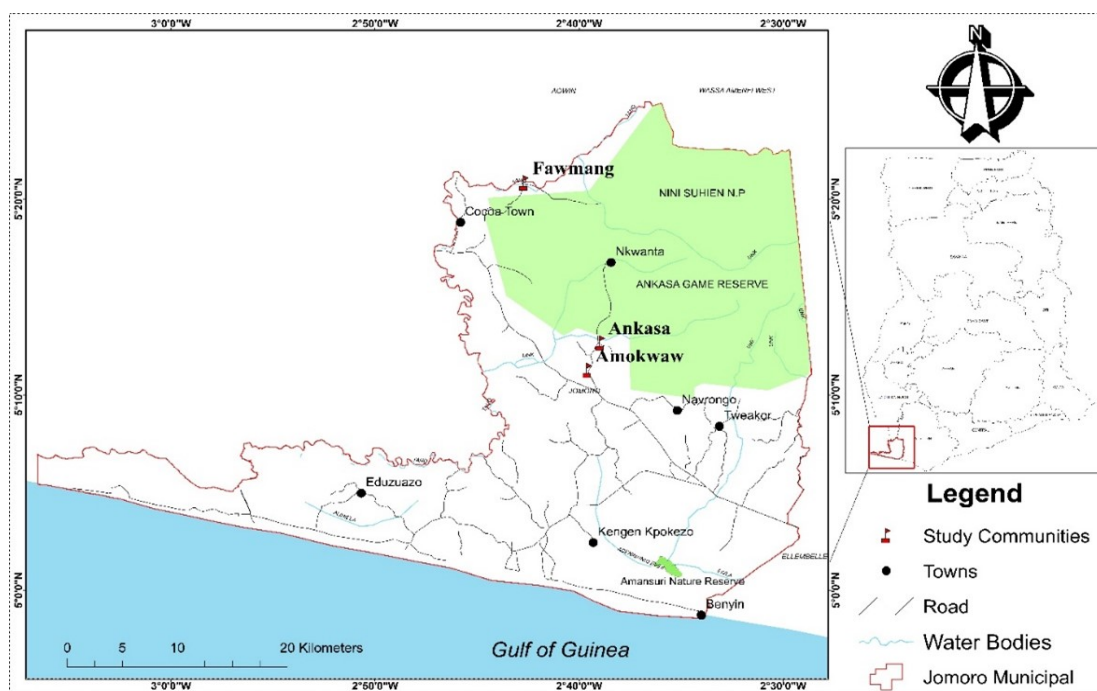

**Figure 1.** Conceptual framework.

### 3. Materials and Methods

#### 3.1. Study Area

The Ankasa Conservation Area (ACA) is geographically positioned at 5°17' North latitude and 2°39' West longitude, within the Jomoro District of southwestern Ghana, directly bordering the Republic of Côte d'Ivoire [41,50]. It encompasses two formerly distinct reserves, the Ankasa Resource Reserve and the Nini Suhien National Park [41,51]. Together, they form the only protected enclave within the wet evergreen high forest zone in Ghana, a globally significant ecosystem that supports remarkable biodiversity, including forest elephants, chimpanzees, bongos, and over 600 butterfly species [41,50,51,63]. Initially gazetted as the Ankasa River Forest Reserve in 1934 to safeguard hydrological systems for agriculture, ACA later underwent phases of timber exploitation. The institutional tide turned with the launch of the Protected Areas Development Programme (PADP) in 1997, culminating in the 2000 management plan that re-envisioned ACA as a hub for biodiversity preservation, community-based natural resource management, and ecotourism. This shift also introduced Community Resource Management Areas (CREMAs), which were designed to decentralize power and integrate local actors into conservation governance [41,50]. Most residents are smallholder farmers cultivating both food crops (e.g., plantain, cassava, vegetables) and cash crops (e.g., cocoa, coconut, oil palm) [49]. While the conservation area boasts of ecotourism infrastructure such as visitor centers, nature trails, and iconic attractions like the Bamboo Cathedral and the "Big Tree," the economic spillovers to local residents remain minimal.



**Figure 1.** Ankasa Conservation Area and adjacent communities.

#### 3.2. Measures

This study employed a five-point Likert scale to measure all items, ranging from 1, indicating Strongly Disagree to 5, Strongly Agree. A total of 11 items were adapted from established studies to align with the present research framework. Minor wording adjustments were made to ensure contextual relevance. Barriers to Community Empowerment was operationalized using three items adopted from [40]. Community Disempowerment was measured with four items adapted from [14]. Also, reduced Local Support for Tourism was assessed using four items derived from [26]. Prior to the main survey, the questionnaire was reviewed and pre-tested by academic experts and the instrument's appropriateness for data collection confirmed.

### 3.3. Data Collection and Analysis

Data collection took place during three field visits to the Ankasa Conservation Area between 5 May and 25 May 2024. The target population comprised the economically active community residents (N = 1,368) of Ankasa, Fawmang, and Amokwaw communities. The study adopted purposive sampling method [59], and a total of 210 respondents were purposively selected. The sampling process followed three main criteria: Local community residents engaged in non-tourism activities, residents engaged in tourism-related activities, and elected or appointed community leaders. Participants included residents, CREMA Executive Committee (CEC) members, assemblymen, tour guides, guesthouse owners, and community elders. Potential respondents were approached by the research team and provided with a brief overview of the study's objectives. Participation was entirely voluntary, and questionnaires were administered only to those who consented. A minimum of 150 valid responses is recommended for structural equation modeling [31]; to meet this requirement, 210 questionnaires were distributed. After excluding incomplete responses, a final dataset of 205 valid cases was retained for analysis.

The study model comprised three latent variables, each measured by their respective observed indicators. Data analysis proceeded as follows: Confirmatory Factor Analysis (CFA) was conducted to assess the reliability and validity of the constructs and Structural Equation Modeling (SEM) was employed to test the hypothesized relationships among constructs [30]. All analyses were conducted using Maximum Likelihood (ML) estimation in Stata 16.

## 4. Results

### 4.1. Participants' Profile

The study comprised 205 respondents from the Ankasa Conservation Area, with a balanced gender distribution (52% male, 48% female). The sample was dominated by adults aged 36-65 years (46%), followed by youth aged 18-35 years (40%), and older adults aged 66-85 years (14%). Most respondents had completed Junior High School education (59%), while 23% had primary education and only 3% had tertiary education. The majority of respondents (76%) were engaged in farming, with traders comprising 11% of the sample. Monthly household incomes were predominantly in the GHC 2000-2900 range (43%), with 25% earning GHC 1000-1900. Notably, 96% of respondents reported that tourism contributed 0% to their household income, highlighting the limited direct economic benefits from tourism activities in the area (Table 1).

Table 1. Participants' profile.

Demographic Variable	Frequency (n)	Percentage (%)
<b>Gender</b>		
Male	107	52
Female	98	48
<b>Age Group</b>		
Youth (18-35)	82	40
Adult (36-65)	94	46
Aged (66- 85)	29	14
<b>Educational Level</b>		
None	12	6
Primary	47	23
JHS	121	59
SHS	19	9
Tertiary	6	3
<b>Primary Occupation</b>		
Farmer	156	76
Public service (tourism)	2	1

Public service (non-tourism)	10	5
Trader	23	11
Unemployed	14	7
<b>Monthly Household Income</b>		
Below GH¢ 1000	19	9
GH¢ 1000- GH¢ 1900	51	25
GH¢ 2000- GH¢ 2900	88	43
GH¢ 3000- GH¢ 3900	33	16
Above GH¢ 3900	14	7
<b>Tourism's Contribution to Monthly Income</b>		
0%	197	96
1%–20%	2	1
21%–60%	4	2
61%–100%	2	1

#### 4.2. Measurement Model

The measurement model was evaluated using Confirmatory Factor Analysis (CFA) to assess construct reliability and validity before testing structural relationships. All constructs demonstrated satisfactory psychometric properties. Cronbach's alpha coefficients ranged from 0.766 to 0.863, and Composite Reliability (CR) values ranged from 0.819 to 0.865, all exceeding the recommended threshold of 0.70. Convergent validity was established as all Average Variance Extracted (AVE) values exceeded 0.50, ranging from 0.518 to 0.648. All factor loadings were statistically significant ( $p < 0.001$ ) and ranged from 0.542 to 0.848, with most exceeding 0.70 (Table 2). The Kaiser-Meyer-Olkin (KMO) measure of sampling adequacy was 0.770, confirming the appropriateness of the data for factor analysis.

**Table 2.** Measurement model.

Construct & Indicators	Loadings	Alpha	CR	AVE
<b>Barriers (Bar)</b>			<b>0.847</b>	<b>0.8470.648</b>
bar_1: Governance deficiencies and opacity in tourism revenue systems	0.808			
bar_2: Influence of dominant actors on local tourism benefits	0.798			
bar_3: Structural economic limitations and underdeveloped industrial capacity	0.810			
<b>Disempowerment (Dsemp)</b>			<b>0.863</b>	<b>0.8650.617</b>
dsemp_1: Tourism development excludes local residents in decision-making	0.806			
dsemp_2: Tourism has not created viable alternative livelihood opportunities	0.688			
dsemp_3: Revenue from tourism has not been used to improve local infrastructure	0.790			
dsemp_4: Communities do not have the capacity for tourism management	0.848			
<b>Reduced Local Support (Lcst)</b>			<b>0.766</b>	<b>0.8190.518</b>
lcst_1: I am not proud of the tourist site due to its little contribution to local development	0.542			
lcst_2: I do not take part in environmental monitoring activities	0.546			
lcst_3: I am dissatisfied with how tourism revenue is shared	0.750			
lcst_4: I am not happy that tourists are visiting my community	0.845			

The hypothesized structural model demonstrated excellent fit to the data based on multiple fit indices. The chi-square test was non-significant ( $\chi^2 (42) = 46.315$ ,  $p = 0.299$ ), indicating no significant difference between the observed and expected covariance matrices. The normed chi-square (CMIN/DF = 1.103) was well below the recommended threshold of 3.0. The Root Mean Square Error of Approximation (RMSEA = 0.022, 90% CI: 0.000-0.054) and Standardized Root Mean Square Residual (SRMR = 0.055) were both below 0.08, indicating close fit. The Comparative Fit Index (CFI = 0.995) and Tucker-Lewis Index (TLI = 0.993) exceeded 0.95, demonstrating excellent incremental fit. These indices collectively confirm that the proposed model adequately represents the underlying data structure.

Hypothesis 1 was supported, demonstrating that perceived barriers have a statistically significant positive effect on community disempowerment with a standardized path coefficient ( $\beta$ ) = 0.192,  $p = 0.015$ , and 95% confidence interval (CI): 0.037-0.347. This indicates that higher levels of structural barriers lead to increased feelings of disempowerment among community members. Hypothesis 2 was not supported, as disempowerment did not significantly predict reduced local support for tourism ( $\beta = 0.058$ ,  $p = 0.480$ , 95% CI: -0.105-0.221). This suggests that the relationship between disempowerment and local support is more complex than initially hypothesized (Table 3 and Figure 3).

**Table 3.** Structural path coefficients and hypothesis testing results.

Hypothesized Path	$\beta$	standard error	t-value	p-value	Decision
H1: Barriers $\rightarrow$ Disempowerment	0.192	0.079	2.430	0.015	Supported
H2: Disempowerment $\rightarrow$ Reduced Local Support	0.058	0.083	0.699	0.480	Not Supported

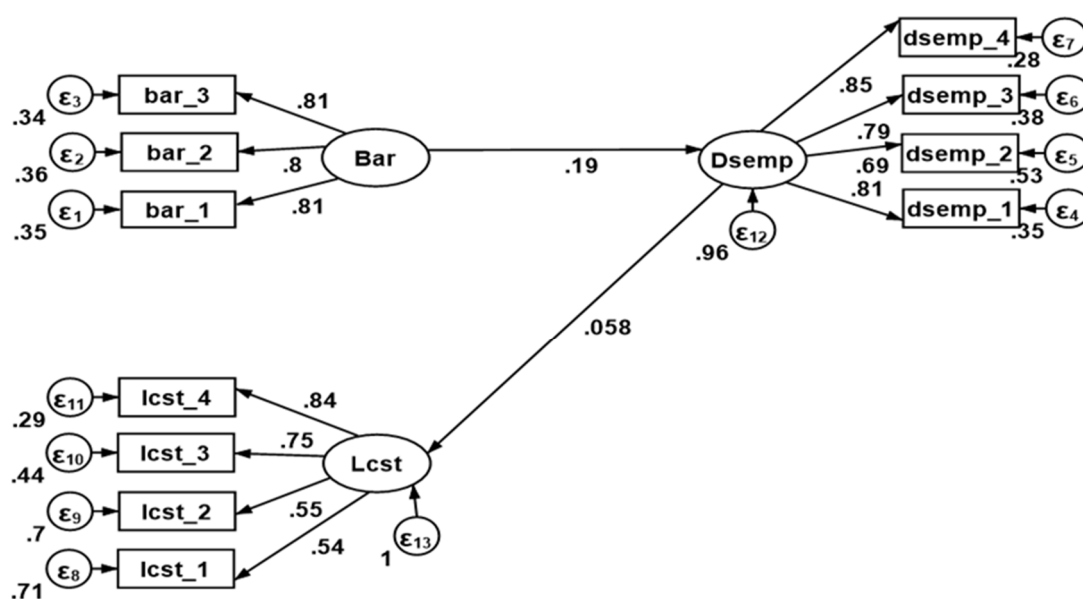

**Figure 3.** Structural model.

## 5. Discussion

This study investigated the relationships between structural barriers, community disempowerment, and local support for tourism development in the Ankasa Conservation Area of Ghana. The findings provide empirical insights that both confirm established theoretical propositions and challenge conventional assumptions about community responses to tourism development in conservation contexts. The significant positive relationship between structural barriers and community disempowerment (H1:  $\beta = 0.192$ ,  $p = 0.015$ ) provides robust empirical validation of theoretical propositions that have dominated community-based tourism literature for decades. This finding aligns with extensive research demonstrating how governance deficiencies, elite capture, and economic limitations systematically marginalize local communities from tourism benefits [2,7,14,43,47]. The standardized path coefficient indicates that structural barriers account for approximately 3.7% of the variance in community disempowerment, representing a meaningful effect size in social science research contexts. The empirical validation of this relationship is particularly significant given the predominant reliance on qualitative methodologies in previous studies. While case studies have consistently documented instances of community exclusion and marginalization [5,10,11,45,57,61,63], the present study provides quantitative evidence of the

systematic nature of these processes. The finding that 96% of respondents reported no tourism income despite living adjacent to a conservation area with tourism potential underscores the pervasiveness of exclusionary mechanisms identified in the conceptual framework. The confirmed barriers-disempowerment relationship validates empowerment theory's emphasis on structural impediments to community empowerment [20,23,24,58]. It also supports political ecology perspectives that highlight how power imbalances and institutional weaknesses perpetuate marginalization in development contexts. The finding extends tourism specific applications of these broader theoretical frameworks. The results resonate strongly with Ahmed and Gasparatos's [2,65] work in Ghana, which similarly demonstrated how structural factors create systematic exclusion despite development interventions. The parallel findings across different sectors suggest that structural barriers to community empowerment represent endemic challenges in Ghana's development landscape rather than tourism-specific phenomena. Comparison with Mawutor and Hajjar's [14] research on community forest governance in Ghana reveals similar patterns of elite capture and governance failures. However, the present study's quantitative approach enables more precise estimation of effect sizes and provides a foundation for comparative analysis across different natural resource management contexts. The non-significant relationship between community disempowerment and reduced local support (H2:  $\beta = 0.058$ ,  $p = 0.480$ ) represents the study's most theoretically provocative finding. This result directly challenges linear assumptions in social exchange theory and tourism area life cycle models, which predict declining support as negative impacts accumulate [15,19,25]. Three explanations emerge for this paradox. First, communities may distinguish between support for tourism as a development strategy versus satisfaction with current implementation. Second, temporal considerations may create disconnect between immediate negative experiences and long-term expectations. Third, cultural factors specific to Ghanaian contexts such as traditional hospitality values, collective decision-making, and historical experiences may moderate the disempowerment-support relationship.

### 5.1. Theoretical Implications

The mixed findings necessitate theoretical framework refinement rather than wholesale rejection. Social exchange theory's limitations in contexts where costs exceed benefits have been noted previously [16,17,20], but this study provides quantitative evidence in conservation tourism contexts. The theory requires extension beyond cost-benefit calculations to incorporate structural factors influencing communities' ability to realize benefits and exercise agency. Stakeholder theory offers additional explanatory potential through its emphasis on relationship quality and procedural justice [27,28]. Communities may distinguish between relationships with tourism as a sector versus specific operators or governance institutions. Integration of empowerment theory, social exchange theory, and stakeholder theory may better explain complex community responses in power-laden contexts.

### 5.2. Practical and Policy Implications

The study's findings must be interpreted within the specific context of Ankasa Conservation Area in Ghana, but they have broader implications for community-based tourism theory and practice. The area's characteristics such as significant biodiversity value, complex institutional arrangements, and communities' limited economic alternatives are representative of conservation tourism contexts across Sub-Saharan Africa. The persistence of community support despite disempowerment may reflect broader patterns of resilience and adaptation in African communities facing development challenges. Research in other sectors suggests that communities often maintain optimism about development interventions while adapting to their limitations [31]. This resilience perspective offers more nuanced understanding than deficit-based models that assume communities will inevitably oppose development initiatives that fail to deliver promised benefits. However, the resilience interpretation should not justify complacency about addressing structural barriers. The finding that communities maintain support despite disempowerment represents both an opportunity and a

warning. It provides a window for implementing necessary governance reforms before support potentially erodes, but it also risks enabling continued exploitation of community goodwill without addressing underlying inequities. The confirmed barriers-disempowerment relationship provides clear guidance for interventions: transparent revenue-sharing mechanisms, meaningful community participation structures, capacity-building programs, and accountability measures. The persistent support finding suggests comprehensive intervention packages rather than isolated reforms, leveraging current community goodwill to build equitable governance systems. For conservation organizations and tourism operators, the findings emphasize the importance of process-oriented approaches that prioritize community agency and participation alongside outcome-oriented measures of success.

### 5.3. Limitations and Future Research

The cross-sectional design precludes definitive causal inferences. The local support construct showed weakest psycho-metric properties, and focus on "reduced support" may not capture attitude complexity. Single conservation area- focus limits generalizability across different cultural and institutional contexts. The non-significant disempowerment-support relationship suggests mediating variables warrant investigation to explain this relationship through mixed-methods approaches. Cultural dimensions require deeper investigation of how indigenous knowledge systems, traditional governance, and local values influence attitudes.

### 5.4. Conclusion

This study provides empirical evidence that structural barriers significantly contribute to community disempowerment in tourism contexts while revealing the unexpected resilience of local support for tourism development. The findings challenge linear assumptions in dominant theoretical frameworks while confirming the importance of addressing structural barriers to community empowerment. The path to sustainable tourism in conservation areas requires urgent attention to governance deficits that create disempowerment while recognizing that community support is a complex phenomenon influenced by factors beyond simple cost-benefit calculations. The persistence of support despite disempowerment represents both an opportunity for building more equitable partnerships and a responsibility to not exploit community goodwill without addressing underlying structural inequities. The ultimate goal should be transforming resilient hope into empowered collaboration that benefits both conservation objectives and community wellbeing

**Author Contributions:** Conceptualization, G.T.; methodology, G.T. and N.I.; software, G.T.; validation, G.T. and N.I.; formal analysis, G.T.; investigation, G.T.; resources, N.I.; data curation, G.T.; writing—original draft preparation, G.T.; writing—review and editing, G.T. and N.I.; visualization, G.T.; supervision, N.I. All authors have read and agreed to the published version of the manuscript.

**Funding:** This research received no external funding.

**Institutional Review Board Statement:** Not applicable.

**Informed Consent Statement:** Informed consent was obtained from all subjects involved in the study

**Data Availability Statement:** Data are available upon request from researchers who meet the eligibility criteria. Kindly contact the first author privately through e-mail.

**Conflicts of Interest:** The authors declare no conflicts of interest.

## References

1. Timothy, D.J. Empowerment and stakeholder participation in tourism destination communities. In *Tourism, Power and Space*; Church, A., Coles, T., Eds.; Routledge: London, UK, 2007; pp. 199–216.
2. Ahmed, S.E.; Gasparatos, A. Multi-dimensional energy poverty patterns around industrial crop projects in Ghana: Enhancing the energy poverty alleviation potential of rural development strategies. *Energy Policy* **2020**, *137*, 111123.
3. Akama, J.S.; Lant, C.L.; Burnett, G.W. Conflicting attitudes toward state wildlife conservation programs in Kenya. *Soc. Nat. Resour.* **2011**, *8*, 133–144.
4. Dodds, R.; Ali, A.; Galaski, K. Mobilizing knowledge: Determining key elements for success and pitfalls in developing community-based tourism. *Curr. Issues Tour.* **2018**, *21*, 1547–1568.
5. Blackstock, K. A critical look at community-based tourism. *Community Dev. J.* **2005**, *40*, 39–49.
6. Mowforth, M.; Munt, I. *Tourism and Sustainability: Development, Globalization and New Tourism in the Third World*, 4th ed.; Routledge: London, UK, 2015.
7. Stone, L.S.; Stone, T.M. Community-based tourism enterprises: Challenges and prospects for community participation; Khama Rhino Sanctuary Trust, Botswana. *J. Sustain. Tour.* **2019**, *19*, 97–114.
8. Baker, J.; Milne, S.; Sandiford, F. Community participation in wildlife conservation in the Ankasa Conservation Area, Ghana. *J. Sustain. Tour.* **2018**, *26*, 1175–1194.
9. Honey, M.; Krantz, D. *Global Trends in Coastal Tourism*; Stanford Environmental Foundation: Stanford, CA, USA, 2007.
10. Saarinen, J.; Rogerson, C.; Hall, C.M. Destinations and communities: New geographies of tourism development in the global South. In *Geographies of Tourism Development and Planning in the Global South*; Saarinen, J., Rogerson, C., Hall, C.M., Eds.; Routledge: London, UK, 2009; pp. 1–12.
11. Tosun, C. Limits to community participation in the tourism development process in developing countries. *Tour. Manag.* **2000**, *21*, 613–633.
12. Cole, S. Information and empowerment: The keys to achieving sustainable tourism. *J. Sustain. Tour.* **2006**, *14*, 629–644.
13. Imanaly, A.; Yang, Z. The influence of tourism revenue sharing constraints on sustainable tourism development: A study of Aksu-Jabagly nature reserve, Kazakhstan. *Asian Geogr.* **2021**, *38*, 1–22.
14. Mawutor, J.K.M.; Hajjar, R. Elite capture and community forest governance in Ghana. *For. Policy Econ.* **2024**, *158*, 103089.
15. UNEP. *Sustainable Tourism Development and Management*; United Nations Environment Programme: Nairobi, Kenya, 2019.
16. Bianchi, R.V. The political economy of tourism development: A critical review. *Ann. Tour. Res.* **2018**, *70*, 88–102.
17. Adams, W.M.; Hutton, J. People, parks and poverty: Political ecology and biodiversity conservation. *Conserv. Soc.* **2007**, *5*, 147–183.
18. Sebele, L.S. Community-based tourism ventures, benefits and challenges: Khama Rhino Sanctuary Trust, Central District, Botswana. *Tour. Manag.* **2010**, *31*, 136–146.
19. Bempah, I.A.; Adjei, P.O.; Agyeman, K.O. Ecotourism and local community development: The case of Ankasa Conservation Area in Ghana. *Tour. Manag. Perspect.* **2019**, *30*, 152–163.
20. Zielinski, S. (2018). Factors that facilitate and inhibit community-based tourism in natural areas of developing countries. Graduate School, Seoul National University Department of Forest Sciences Forest Environmental Sciences Major
21. Eshun, G.; Asiedu, A.B. Community-based ecotourism in Ghana: Challenges and prospects. *Tour. Plan. Dev.* **2021**, *18*, 456–472.
22. Asiedu, A.B. Making ecotourism more supportive of rural development in Ghana. *W. Afr. J. Appl. Ecol.* **2002**, *3*, 1–18.
23. Mitchell, J.; Ashley, C. *Tourism and Poverty Reduction: Pathways to Prosperity*; Earthscan: London, UK, 2010.
24. Ap, J. Residents' perceptions on tourism impacts. *Ann. Tour. Res.* **1992**, *19*, 665–690.
25. Gursoy, D.; Rutherford, D.G. Host attitudes toward tourism: An improved structural model. *Ann. Tour. Res.* **2004**, *31*, 495–516.

26. Doxey, G.V. A causation theory of visitor-resident irritants: Methodology and research inferences. In *Proceedings of the Travel Research Association 6th Annual Conference*; Travel Research Association: Salt Lake City, UT, USA, 1975; pp. 195–198.
27. Sharpley, R. Host perceptions of tourism: A review of the research. *Tour. Manag.* **2014**, *42*, 37–49.
28. Freeman, R.E. *Strategic Management: A Stakeholder Approach*; Pitman: Boston, MA, USA, 1984.
29. Byrd, E.T.; Bosley, H.E.; Dronberger, M.G. Comparisons of stakeholder perceptions of tourism impacts in rural eastern North Carolina. *Tour. Manag.* **2009**, *30*, 693–703.
30. Anderson, J.C.; Gerbing, D.W. Structural equation modeling in practice: A review and recommended two-step approach. *Psychol. Bull.* **1988**, *103*, 411.
31. Hair, J.F.; Black, W.C.; Babin, B.J.; Anderson, R.E. *Multivariate Data Analysis*, 7th ed.; Pearson: Harlow, UK, 2010.
32. Andereck, K.L.; Valentine, K.M.; Knopf, R.C.; Vogt, C.A. Residents' perceptions of community tourism impacts. *Ann. Tour. Res.* **2005**, *32*, 1056–1076.
33. Dangi, T.B.; Jamal, T. An integrated approach to "sustainable community-based tourism". *Sustainability* **2016**, *8*, 475.
34. Giampiccoli, A.; Saayman, M. Community-based tourism development model and community participation. *Afr. J. Hosp. Tour. Leis.* **2018**, *7*, 1–27.
35. Nunkoo, R.; Ramkissoon, H. Developing a community support model for tourism. *Ann. Tour. Res.* **2011**, *38*, 964–988.
36. Nunkoo, R.; Ramkissoon, H. Power, trust, social exchange and community support. *Ann. Tour. Res.* **2012**, *39*, 997–1023.
37. Nunkoo, R.; Smith, S.L.; Ramkissoon, H. Residents' attitudes to tourism: A longitudinal study of 140 articles from 1984 to 2010. *J. Sustain. Tour.* **2013**, *21*, 5–25.
38. Croes, R.; Rivera, M.A. Tourism's potential to benefit the poor: A social accounting matrix model applied to Ecuador. *Tour. Econ.* **2017**, *23*, 29–48.
39. Wani, M.D.; Dada, Z.A.; Shah, S.A. The impact of community empowerment on sustainable tourism development and the mediation effect of local support: A structural equation modeling approach. *Community Dev.* **2024**, *55*, 50–66
40. Imanaly Akbar & Zhaoping Yang (2021): The influence of tourism revenue sharing constraints on sustainable tourism development: a study of Aksu-Jabagly nature reserve, Kazakhstan, *Asian Geographer*, DOI: 10.1080/10225706.2021.1894462
41. Wildlife Division. (2000). Policy for collaborative community-based wildlife management. Government of Ghana.
42. Scheyvens, R., & van der Van der Watt, H. (2021). Tourism, Empowerment and Sustainable Development: A New Framework for Analysis. *Sustainability*, 13(22). <https://doi.org/10.3390/su132212606>
43. Amoako-Atta, E. E., Dayour, F. F., & Bonye, S. Z. (2020). Community participation in the management of Wechiau Community Hippo sanctuary, Ghana. *Ghana Journal of Development Studies*, 17(1), 1-24.
44. Han, G., Wu, P., Huang, Y., & Yang, Z. (2014). Tourism development and the disempowerment of host residents: types and formative mechanisms. *Tourism Geographies*, 16(5), 717-740. <https://doi.org/10.1080/14616688.2014.957718>
45. Thomas Yeboah (2021): Dynamics of Ecotourism Benefits Distribution, *Tourism Planning & Development*, DOI: 10.1080/21568316.2021.1876161
46. Gabriel Eshun & Eva Tagoe-Darko (2015) Ecotourism development in Ghana: A postcolonial analysis, *Development Southern Africa*, 32:3, 392-406, DOI: 10.1080/0376835X.2015.1020218
47. Ricky Yao Nutsugbodo & Collins Adjei Mensah (2020): Benefits and barriers to women's participation in ecotourism development within the Kakum Conservation Area (Ghana): Implications for community planning, *Community Development*, DOI: 10.1080/15575330.2020.1825977
48. Adeyanju, S., O'connor, A., Addoah, T., Bayala, E., Djoudi, H., Moombe, K., ... & Sunderland, T. (2021). Learning from community-based natural resource management (CBNRM) in Ghana and Zambia: lessons for integrated landscape approaches. *International Forestry Review*, 23(3), 273-297.

49. Ansah, I. K. (2018). Residents' Perception of Tourism Impact in Ankasa Conservation Area. University of Cape Coast
50. Ashiagbor, G., Abubakar, S. K., Inusah, S. S., Adjapong, A. O., Osei, G. N., & Laari, P. B. (2024). Analysis of the Impact of Agriculture and Logging on Forest Habitat Structure in the Ankasa and Bia Conservation Area of Ghana. *Ecology and Evolution*, 14(12), e70712.
51. Owusu, G., Anning, A. K., Belford, E. J., & Acquah, E. (2022). Plant species diversity, abundance and conservation status of the Ankasa Resource Reserve, Ghana. *Trees, Forests and People*, 8, 100264.
52. Wondirad, A., Tolkach, D., & King, B. (2020). Stakeholder collaboration as a major factor for sustainable ecotourism development in developing countries. *Tourism management*, 78, 104024.
53. Koutra, C., & Edwards, J. (2012). Capacity building through socially responsible tourism development: A Ghanaian case study. *Journal of travel research*, 51(6), 779-792.
54. Bei Tian, Arie Stoffelen & Frank Vanclay (2023) Ethnic tourism in China: tourism-related (dis)empowerment of Miao villages in Hunan province, *Tourism Geographies*, 25:2-3, 552-571, DOI: 10.1080/14616688.2021.1938657
55. Pius Siakwah, Regis Musavengane & Llewellyn Leonard (2019): Tourism Governance and Attainment of the Sustainable Development Goals in Africa, *Tourism Planning & Development*, DOI: 10.1080/21568316.2019.1600160
56. Eshun, G. & Mensah, K. (2020). Agrotourism Niche-Market in Ghana: A MultiStakeholder Approach. *African Journal of Hospitality, Tourism and Leisure*, 9(3):319-334. DOI: <https://doi.org/10.46222/ajhtl.19770720-21>
57. Christoph Neger (2021): Ecotourism in crisis: an analysis of the main obstacles for the sector's economic sustainability, *Journal of Ecotourism*, DOI: 10.1080/14724049.2021.1942019
58. Tumusiime, D. M., & Vedeld, P. (2012). False promise or false premise? Using tourism revenue sharing to promote conservation and poverty reduction in Uganda. *Conservation and Society*, 10(1), 15-28.
59. Ghana Statistical Service. (2021). Population and Housing Census: Summary Report of Provisional Results. Accra. Ghana Statistical Service, P.O Box GP 1098, Ghana
60. Bryman, A. (2016). *Social Research Methods* Bryman, Oxford University Press. 5th Edition.
61. Bayala, E. R. C., Zida, M., Asubonteng, K. O., Ros-Tonen, M. A., Reed, J., Siangulube, F. S., ... & Sunderland, T. (2025). Assessing CREMAs' Capacity to Govern Landscape Resources in the Western Wildlife Corridor of Northern Ghana. *Environmental Management*, 1-16.
62. Baruah, M. (2017). Facipulation and elite formation: Community resource management in Southwestern Ghana. *Conservation and Society*, 15(4), 371-383.
63. Agyare, A. K., Holbech, L. H., & Arcilla, N. (2024). Great expectations, not-so-great performance: Participant views of community-based natural resource management in Ghana, West Africa. *Current Research in Environmental Sustainability*, 7, 100251.
64. deGraft-Johnson, K. A. A., Blay, J., Nunoo, F. K. E., & Amankwah, C. C. (2010). Biodiversity threats assessment of the Western Region of Ghana. The integrated coastal and fisheries governance (ICFG) initiative Ghana.
65. Ahmed, A., & Gasparatos, A. (2020). Reconfiguration of land politics in community resource management areas in Ghana: Insights from the Avu Lagoon CREMA. *Land use policy*, 97, 104786
66. Sofield, T. H. (2003). *Empowerment for sustainable tourism development*. Emerald Group Publishing

**Disclaimer/Publisher's Note:** The statements, opinions and data contained in all publications are solely those of the individual author(s) and contributor(s) and not of MDPI and/or the editor(s). MDPI and/or the editor(s) disclaim responsibility for any injury to people or property resulting from any ideas, methods, instructions or products referred to in the content.