

Article

Not peer-reviewed version

---

# Analysis of the Evolution of Water Quality in Tanks according to the Connections and Operation Mode. Application to the most Suitable Design

---

[Marta Hervás](#) , [Fernando Martínez-Alzamora](#) <sup>\*</sup> , Pilar Conejos

Posted Date: 1 April 2024

doi: 10.20944/preprints202404.0025.v1

Keywords: Simulation; water quality; water age; storage tanks; hydraulic networks



Preprints.org is a free multidiscipline platform providing preprint service that is dedicated to making early versions of research outputs permanently available and citable. Preprints posted at Preprints.org appear in Web of Science, Crossref, Google Scholar, Scilit, Europe PMC.

Copyright: This is an open access article distributed under the Creative Commons Attribution License which permits unrestricted use, distribution, and reproduction in any medium, provided the original work is properly cited.

Disclaimer/Publisher's Note: The statements, opinions, and data contained in all publications are solely those of the individual author(s) and contributor(s) and not of MDPI and/or the editor(s). MDPI and/or the editor(s) disclaim responsibility for any injury to people or property resulting from any ideas, methods, instructions, or products referred to in the content.

Article

# Analysis of the Evolution of Water Quality in Tanks According to the Connections and Operation Mode. Application to the Most Suitable Design

Marta Hervás <sup>1,2</sup>, Fernando Martínez-Alzamora <sup>3,\*</sup> and Pilar Conejos <sup>1,2</sup>

<sup>1</sup> Department of Hydraulic Engineering and Environment, Universitat Politècnica de València, 46022 Valencia, Spain; marherc2@upv.edu.es, pconejos@dihma.upv.es

<sup>2</sup> Digital Twin Specialist at G.O. Idrica, 46010 Valencia, Spain

<sup>3</sup> Research Institute of Water and Environmental Engineering (IIAMA), Universitat Politècnica de València, 46022 Valencia, Spain; fmartine@hma.upv.es

\* Correspondence: fmartine@hma.upv.es

**Abstract:** The analysis and simulation of water quality in distribution networks is a complex issue of great concern today. The analysis of the evolution of water age, as a simple indicator of water quality in the network, is of great interest in both design and operation phases. Understanding the factors that have the strongest influence on water quality is key to developing adequate strategies aimed at preserving it. This paper firstly analyses the factors with biggest influence in the tanks water age, to support the selection of the most appropriate configuration from the point of view of water quality during design phases. Then, the main considerations when modelling tanks following the different mixing models considered in Epanet have been presented. Also, a real tank behaviour has been characterised through field measurements and Epanet simulations in order to determine the best fitted mixing model.

**Keywords:** simulation; water quality; water age; storage tanks; hydraulic networks

## 1. Introduction

The primary objective of a Water Distribution Network (WDN) is to provide users with the required demand under optimal pressure and quality conditions. As water travels from treatment plants to users' taps, Water Quality (WQ) parameters change, including an increase in water age, a decrease in disinfectant concentration (chlorine), and an increase in disinfectant byproducts (THMs).

Under normal operating conditions, changes in WQ are caused by multiple factors. Chemical reactions that begin during the treatment process continue within bulk water and pipe walls. Additionally, water from different sources can be mixed in tanks and network junctions modifying its quality [1]. Furthermore, accidental or intentional contamination episodes can occur, which can have serious consequences on the WDN [2,3].

Analysing the network's behaviour in terms of WQ is crucial for gaining a deeper understanding of the processes involved. This enables operators to take more accurate actions to preserve WQ and enhance the security and resilience of the system.

Hydraulic models followed by WQ models are necessary to determine travelling times, water age, blending, and subsequent WQ throughout the system by considering the various water travelling paths and quality transformations. It is impossible to accurately determine these factors without the use of such models [4–6].

Epanet [7] is a widely used software for simulating hydraulics and WQ in WDN. These models provide the concentration of a certain substance, source tracing, water age, and occasionally traveling times at any point in the network [8].

But developing a reliable WQ model with Epanet is even a complex task that involves multiple factors. Firstly, a valid hydraulic model is necessary to accurately determine the pipe flow rates, which must be detailed enough and properly calibrated [9,10]. Therefore, it is crucial to model all elements of the system from a WQ perspective to obtain accurate and coherent simulation results, particularly tanks where water can be retained for long time, and small pipes if the WQ model extends to the taps. Furthermore, it is crucial to have a demand allocation that closely reflects reality. This is because water can remain stagnant for long periods before being consumed in dead end pipelines.

WQ is mainly affected by reactions in bulk water, interactions with pipe walls, flow mixing, ageing and mixing within storage tanks [11]. Since WQ in WDN is a very broad field of study, this paper focuses on the analysis of the changes that occur in storage tanks.

Storage tanks are the network component with the greatest impact on WQ because water spends a certain amount of time in them before being released back into the network, and in the meantime important changes in quality parameters can occur [12,13]. These changes can include increased water age and various aesthetic and chemical reactions, such as chlorine decay, growth of disinfectant by-products, and changes in appearance [14].

In order to achieve accurate simulation results when developing a WQ analysis of a WDN, it is necessary to adequately model water tanks, as these elements affect the behaviour of the whole network [15–18].

WQ deterioration in tanks is a common issue discussed in literature. Studies on storage tanks can be classified into three areas: (1) monitoring and sampling [19–21], (2) physical-scale modelling [22–24], and (3) mathematical modelling [25,26]. This paper focuses on mathematical modelling (3) and its validation with real measurements (1).

With this aim, Epanet 2.2 software has been used to mathematically determine the evolution of WQ in tanks. When modelling tanks in Epanet, two main aspects must be considered regarding the evolution of WQ: the selected mixing model and the connection of the inlet/outlet pipes to the tank and to the system, apart from the mode of operation. The main purpose of this document is to analyse how the mixing model and the arrangement of the tank pipe connections affect water age and compare these results with field measurements for a real case study.

## 2. Fundamentals

### 2.1. Epanet's Mixing Models within Storage Tanks

The real behaviour of water within storage tanks is complex and depends on several aspects such as the tank geometry, pipe inlets/outlets, convection, diffusion, and turbulent flow. Therefore, Computational Fluid Dynamics (CFD) methods can be used to precisely model real tank behaviour [27]. The use of CFD methods in tank modelling is of great interest during the design phase, since they provide detailed insight into momentum and mass transport in tanks, allowing for the determination of the best internal tank configurations to preserve WQ [28,29].

However, solving these equations requires significant time and computational power, which hinders their integration into a comprehensive quality model of the entire network.

Epanet 2.2 implements four different types of models to characterize mixing within storage tanks [7], as presented in Figure 1. In this case, it is assumed that elements behave ideally, with clearly defined preferential paths and stagnation zones. When modelling a tank with Epanet, the objective is to select the mixing model that best represents reality.

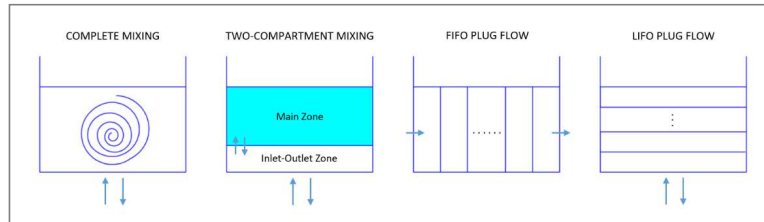

Figure 1. Tank mixing models in Epanet [7].

- **Complete Mixing:** This model assumes that all water entering the tank is immediately and fully mixed with the water already present in the tank.
- **Two-Compartment Mixing:** The storage volume of a tank is divided into two compartments, both of which are assumed to be completely mixed. The inlet/outlet pipes of the tank are located in the first compartment. When new water enters the tank, it mixes with the water in the first compartment. If the first compartment is full, the excess water flows into the second compartment, where it mixes with the water already stored there. Water exits the tank from the first compartment. When the first compartment is emptied, it receives an equivalent amount of water from the second compartment to make up the difference as long as it has stored water. The first compartment simulates short-circuiting between inflow and outflow, while the second compartment simulates the dead zones of the tank.
- **FIFO Plug Flow:** This model assumes that water does not mix during its residence time in a tank, instead it is stored in separated parcels. Water parcels move through the tank in a segregated manner, with the first parcel to enter (First Input) also being the first to leave (First Output). This behaviour occurs when inlet and outlet pipes are located at opposite ends of the tank and baffles are present inside, or when tanks are fed from top.
- **LIFO Plug Flow:** This model is similar to the previous one but in this case water parcels stack up on top of each other, with water entering and leaving the tank at the bottom in reverse order of entry (Last Input is First Output). This behaviour is typical when both inlet and outlet pipes are very close to each other, or when there is a single inlet/outlet pipe.

## 2.2. Influence of Inlet/Outlet Pipe Configuration in the Mixing Model

When determining the mixing model that best simulates the real behaviour of WQ in a tank, several aspects need to be considered. Firstly, it is important to note that the different models available in Epanet 2.2 aim to reproduce the interaction between inlet/outlet volumes with the stored volume for each time interval. All of these models are dependent on the inlet/outlet pipe disposal, tank geometry, and baffles configuration to guide the flows inside the tank if present, as shown in Figure 2.

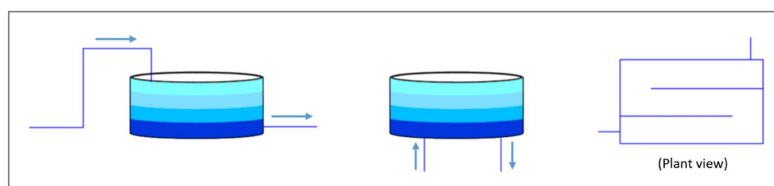

Figure 2. Inlet/Outlet pipe configuration and baffles in tanks (from left to right).

Furthermore, the physical configuration of inlet and outlet pipes has a significant impact on the flow of water inside a tank, including the creation of preferred paths and stagnation zones. As a result, the selection of the most appropriate mixing model is influenced by the inlet/outlet pipe configuration.

For instance, when using separated inlet/outlet pipes with baffles, it is expected that the FIFO model will be the most accurate. However, in a pipe configuration where the inlet and outlet pipes are close, the LIFO or Two-Compartment Mixing models are likely to provide the most accurate results.

### 2.3. Influence of Tank Connection to the System in the Mixing Model

It is not only the disposal of the inlet/outlet pipes that affects the WQ in tanks, but also the connection of the tanks to the network. Figure 3 shows two different connections which significantly affect the daily water renewal rate and the evolution of water age inside the tank.

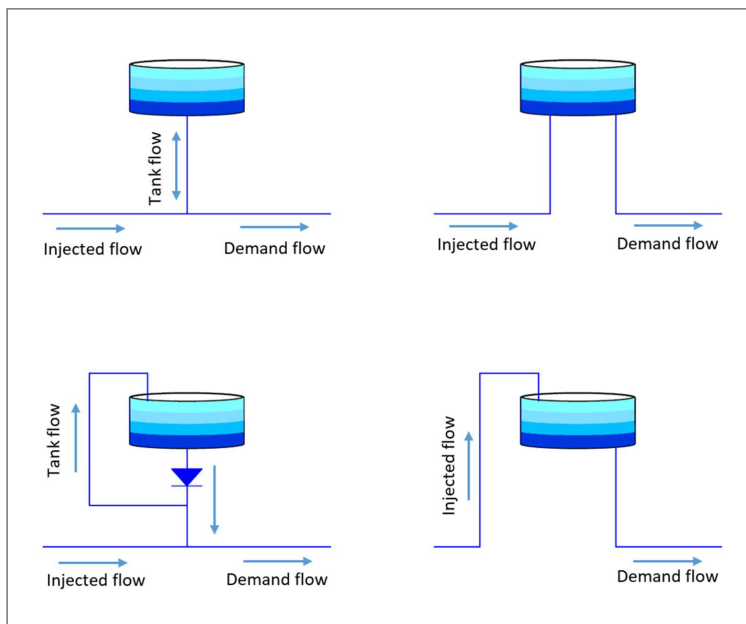

**Figure 3.** Single (left) and independent (right) pipe connections to the system, with bottom inlet pipes (up) and upper inlet pipes (down).

In a single pipe connection, the tank behaves as a balance tank. It fills when the demanded flow is lower than the injected flow and empties in the opposite case. The daily renewal rate in this case depends on the tank regime. The higher the difference between the maximum and minimum operating levels of the tank, the higher the daily renewal rate.

Tanks with independent inlet/outlet pipe connections have a lower water age because all the demanded water flow enters the tank, resulting in a higher daily renewal rate compared to tanks with a single pipe connection.

### 2.4. Influence of Tank Operation on Water Age

Tank operation is also closely linked to WQ, which determines the daily renewal rate. Regulating tanks have regular inlet and outlet flows, and minimum and maximum operation settings govern the daily renewal rate.

In the case of balance tanks, their operating regime is not regular, so it is not possible to determine the daily renewal rate a priori. Therefore, low daily renewal rates are expected when the

tank is almost full, and high renewal rates are expected in certain situations when the network demands high flows from them (emergencies).

The volume of the tank compared to their inflow and outflow is also important, as this in turn determines the operating regime. In particular, pressure-breaking tanks have minimal storage capacity, so they have little influence on the system's WQ.

#### 2.5. Cycling Simulation Results for Water Quality Analysis: Influence of Initial Quality

To achieve accurate and coherent simulation results when developing a WQ model of a network, it is necessary to first model the hydraulic behaviour properly and allow enough simulation time for all hydraulic and quality results to stabilise, reaching a cyclic behaviour as shown in Figures 4 and 5. This includes pressures, tank levels, flows, and water age. At this stage, the control laws for the regulating elements of the network, including the initial levels of tanks, must be adjusted to match the values at which they repeat after a certain simulation time.

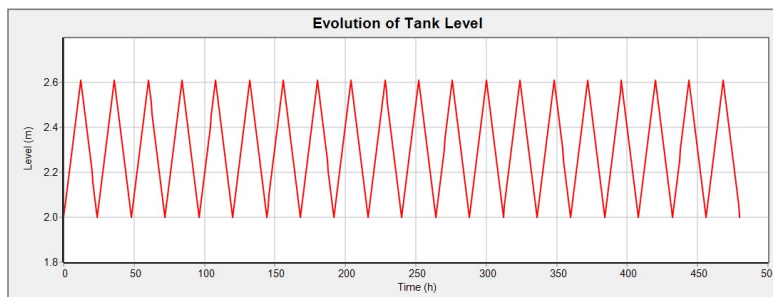

Figure 4. Evolution of a tank level. Cyclic behaviour.

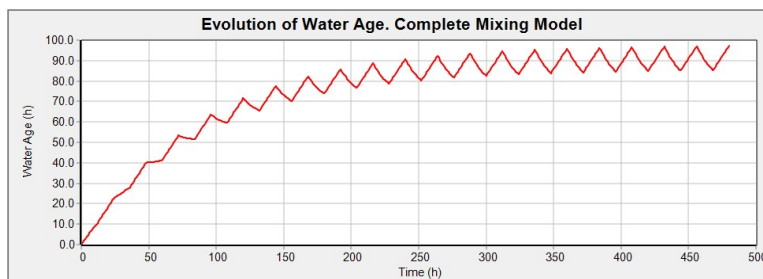

Figure 5. Evolution of water age on a tank. Complete mixing model.

It is important to note that in Epanet, when referring to tank quality, it corresponds to the WQ in the outlet side, and particularly to the outer tank segment for FIFO and LIFO mixing models.

For Complete Mixing models, the WQ at the tank outlet is the same as the average WQ of the entire volume of water within the tank. Therefore, the initial quality applies to all the water contained in the tank.

However, for Two-Compartment Mixing, FIFO Plug Flow, and LIFO Plug Flow, it is not possible to define the initial quality at the inner compartments or parcels. This is because, through the Epanet interface or Toolkit, users only have access to set the WQ at the outer tank section. It is therefore important to cycle the quality behaviour in the tanks before performing any analysis.

### 3. Analysis of Maximum Water Age in Tanks as a Function of the Most Influential Factors

Regarding water age, its evolution is mostly affected by the rate of water reserve versus daily injected volume, the tank operation (including pumping and demand regimes), and the tank's connection to the system, as discussed above.

The following graphs presented in Figures 7 and 8 display how water age in tanks is mainly affected by is affected by three factors: 1) the connection of inlet/outlet pipes to the network, 2) the ratio of reserve versus injected volume, and 3) the pumping regime. In all cases, complete mixing was assumed to provide an average scenario for comparison purposes. Also, results have been obtained for a typical south-European water demand curve (continuous lines), represented in Figure 6, and its corresponding continuous average demand (dashed lines).

**Commented [M1]:** Figure citations should be numbered in order of appearance. We detected "Figures 7 and 8" appears before "Figure 6", please rearrange all the figure citations to appear in numerical order.

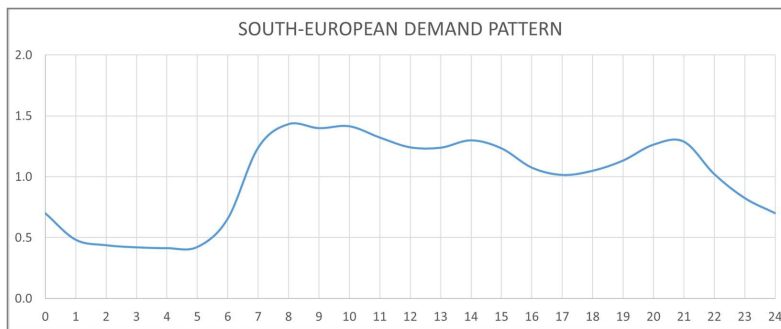

**Figure 6.** South-European demand pattern considered.

For a single input/output pipe connection (Figure 7), the results obtained for continuous and modulated demand are very similar in almost every scenario analysed, except for very extended pumping regimes. In extreme cases, when the pumping flow equals the demanded flow, no water enters the tank, resulting in a noticeable increase in water age. In such cases, it would be more accurate to work with the curves obtained with a modulated demand.

Figure 7 demonstrates that, in the case of a single pipe connection, water age increases with both the rate of reserve volume and the pumping time for the same daily-injected volume.

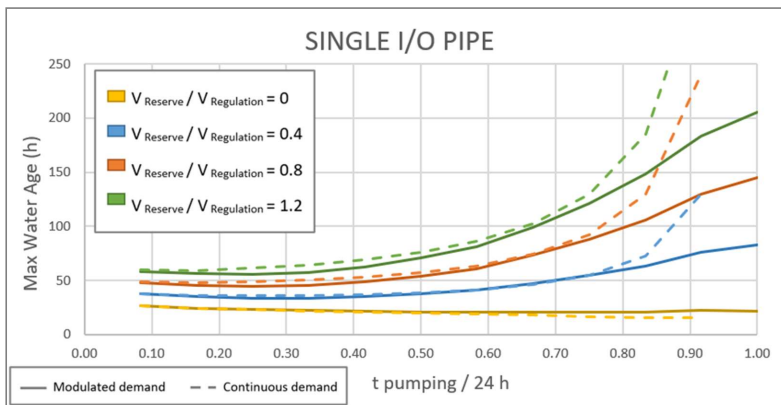
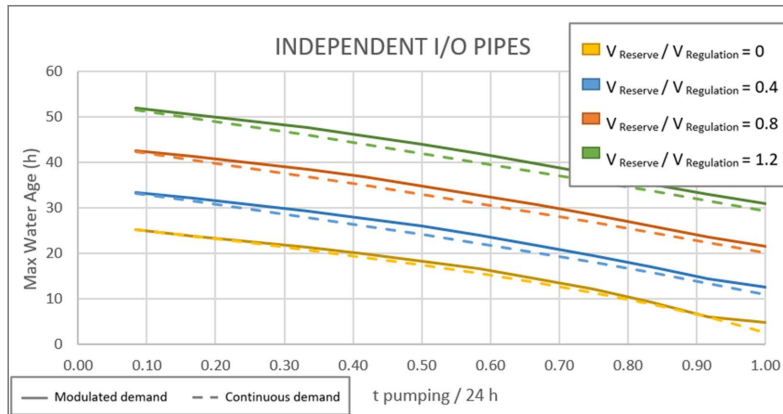

**Figure 7.** Evolution of water age in a tank with single pipe connection to the network.

7

For independent inlet/outlet pipes, the results for continuous average demand and modulated demand are also similar, even for extended pumping regimes, as shown in Figure 8. Water age is lower in all cases than for a single connection and still increases with the rate of reserve volume.

However, in contrast to the previous case, water age now decreases as the pumping time increases, since a steady inlet flow continuously renews the water stored in the tank.



**Figure 8.** Evolution of water age in a tank with independent inlet/outlet pipe connection to the network.

The rate of reserve versus injected volume is what influences the evolution of water age, instead of the total tank volume. Additionally, the tank demand regime, whether continuous or modulated, has little influence on the results achieved. Therefore, these results can be applied regardless of the tank's demand pattern, particularly for independent inlet/outlet pipe configurations.

Overall, the analysis shows that an independent inlet/outlet pipe configuration presents better results in terms of water age. This configuration allows for higher reserve volumes, which is beneficial for supplying demand peaks and emergencies. Additionally, the dependence on the pumping regime is lower, allowing for the implementation of different pumping strategies, such as optimizing the pumping schedule to minimize energy costs, without penalizing water age.

#### 4. Analysis of Water Age Evolution for Different Mixing Models

In previous sections, the influence of certain parameters on water age has been analysed for design purposes, assuming complete mixing. However, Epanet offers other mixing models for simulating the tank behaviour. A comparison between the results obtained with the different models is made in the following sections.

##### 4.1. Case Study 1

The Case Study 1 (Figure 9) focuses on the evolution of water age in a tank connected to a single inlet/outlet pipe, which serves as a balance tank, for the four mixing models available in Epanet. A 2,000 m<sup>3</sup> balance tank of the geometrical characteristics given in Table 1 is considered.

Table 1. Tank properties.

TANK PROPERTIES	
Diameter (m)	26.0
Minimum level (m)	0.0
Maximum level (m)	4.0
Initial level (m)	2.0

There is a demand node that requires 7.5 l/s for 12 hours at night and 22.5 l/s for the remaining 12 hours at daylight. The whole system is fed by a continuous flow of 15 l/s coming from an upper reservoir and controlled by a Flow Control Valve (FCV), resulting in a daily average flow to the balance tank of 0.

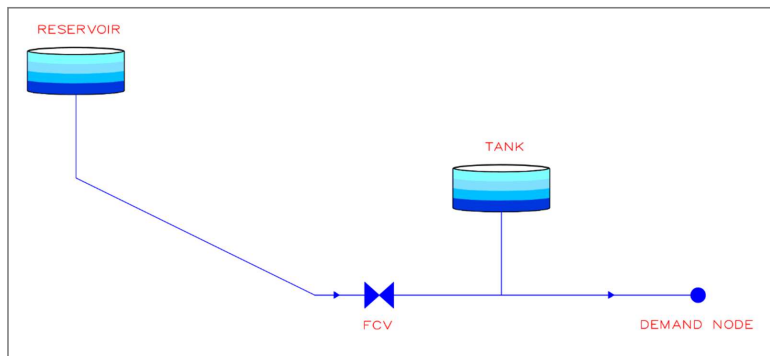

Figure 9. Case Study 1 network diagram.

Figure 10 summarises the hydraulic behaviour of Case Study 1:

- At night, when the demand is lower, the tank fills up from 2.0 to 2.6 meters.
- During the day, as demand increases, the tank level drops from 2.6 to 2.0 meters.

Note that the presented tank configuration, with a single pipe connection to the network, does not allow for simultaneous inlet and outlet flows to the tank. Therefore, the tank fills when the injected flow is higher than the demand flow and empties when the injected flow is lower than the demand flow.

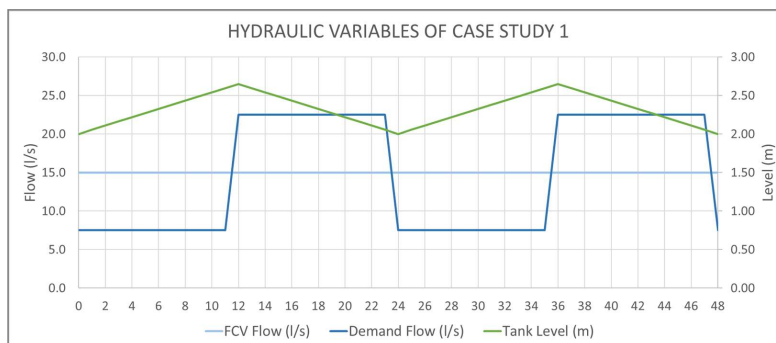

Figure 10. Evolution of the main hydraulic variables of Case Study 1.

Even though the maximum level of the tank is 4 m, it only reaches 2.6 m, so in practice, according to the real maximum and minimum levels reached, the used volume of the tank is 1,300 m<sup>3</sup> instead of its total capacity of 2,000 m<sup>3</sup>. As a result, the daily water renewal rate is about 25%, so it takes approximately 4 days to renew all the water stored in the tank.

$$\text{Daily Renewal Rate (\%)} = \frac{(15 - 7.5) * 12 * 3.6}{1,300} * 100 \approx 25 \% \quad (1)$$

Finally, the hydraulic and quality results in Case Study 1 stabilise at approximately 20 days or 480 hours of simulation time (Figure 5). Therefore, the analysis is focused on the results from the last 48 hours of the simulation.

#### Complete Mixing

In Complete Mixing, all water that enters the tank fully mixes with the water already inside. Figure 11 shows that as the tank fills, new water with a low water age enters the tank, so water age decreases. Conversely, when the tank is being emptied, water age increases as the stored volume keeps ageing.

The maximum water age is 97.75 hours, which coincides with the renewal time of all stored volume, approximately 4 days. This can also be calculated using the following expression [30]:

$$T_r = 24 \cdot \frac{V_T}{\sum V_i} \quad (2)$$

where  $T_r$  is the renewal time in hours,  $V_T$  the total tank volume and  $V_i$  the incoming volumes to the tank during one day.

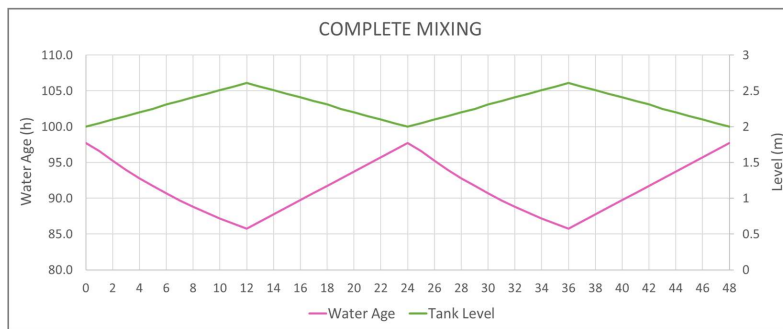

**Figure 11.** Evolution of water age and tank level. Complete mixing.

#### Two-Compartment Mixing

In Two-Compartment Mixing, the total available storage volume of the tank is divided into two compartments, both of which are assumed to be completely mixed. The inlet/outlet pipes of the tank are located in the first compartment.

In Epanet, the mixing fraction must be defined as the fraction of the total volume dedicated to the first compartment. The simulation in the example was performed with mixing fractions of 0.2, 0.5, and 0.8, and the results are displayed in Figure 12.

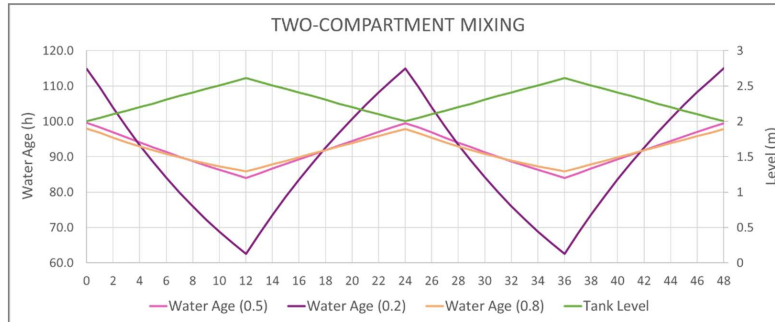

Figure 12. Evolution of water age and tank level. Two-Compartment mixing.

Results obtained for a mixing fraction of 0.5 and 0.8 are similar to those obtained for complete mixing. This is because the mixing fraction is related to the total volume (max. level of 4 m) and not to the actual volume used (max. level of 2.6), as depicted in the following Figure 13, so all the used volume is mostly or totally located in the first compartment.

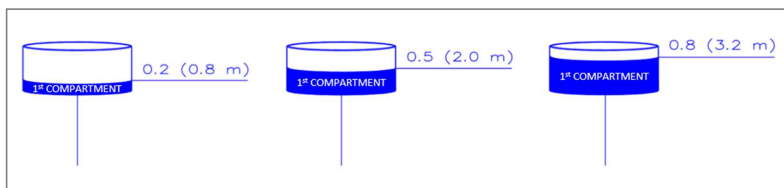

Figure 13. Mixing fractions and levels of the first compartment.

However, when the mixing fraction is 0.2, the tank behaves as a real two-compartment mixer. The first compartment only reaches a level of 0.8 m, and from there on, all volume corresponds to the second compartment. When the tank is filling, new water enters the first compartment and mixes completely with the water already present. This water is less than the total water, so water age decreases faster (remember that in these cases the tank quality reported by Epanet is that of the first compartment). On the contrary, during the emptying of the tank, water exits the first compartment and is replaced by water from the second compartment, which has a higher water age. This results in a faster increase in water age.

The results indicate that the hydraulic behaviour of the tank and the fixed mixing fraction are crucial when selecting a two-compartment mixing system. Special attention should be paid to the renewed volume and initial level of the tank. The hydraulic behaviour affects the accurate definition of the mixing fraction, which in turn determines the accuracy of the results obtained.

#### *FIFO Plug Flow*

FIFO Plug Flow model assumes that water parcels move through the tank separately. The first parcel to enter is also the first to leave. In the case of opposite inlet and outlet pipes, this would correspond to a horizontal movement of the parcels. Also, the presence of baffles within tanks will lead to FIFO behaviour. In the case of vertical stratification, it would correspond to filling the tank from the top.

To enhance comprehension of the behaviour of FIFO Plug Flow, the scheme presented in Figure 14 was developed for the last case. It shows the evolution of the water age of the parcels in the tank.

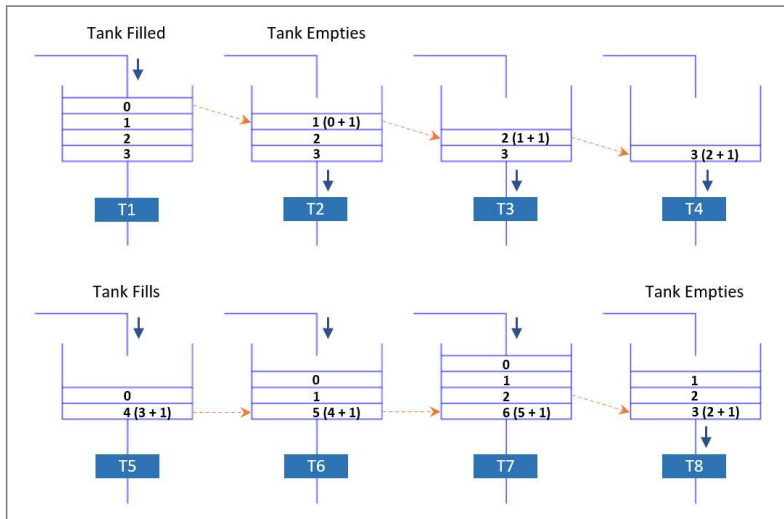

**Figure 14.** Evolution of water age in the parcels of the tank. FIFO Plug Flow. Numbers on parcels stand for the water age, in h. Each figure represents the evolution of parcels for a time step of 1 h.

Starting from a full tank and assuming a fixed time steps of 1 h, observing the movement of various water parcels within the tank can provide a better understanding of the FIFO Plug Flow behaviour.

As the tank empties, upper parcels age at a rate of 1 hour per time step. This ensures that each parcel reaches the lower location, which is determined by Epanet, with the same water age. Therefore, the water age simulation presents a constant value when the tank is emptying.

Furthermore, as the tank fills, upper parcels are generated with a lower water age, which increases when filling at a rate of 1 h. Meanwhile, the lower parcel remains stored and ages with each time step at a rate of 1 h. Therefore, during the filling process, the simulation shows a constant rate of increase in water age.

The simulation results, shown in Figure 15, follow this behaviour (remember that the tank quality reported by Epanet is that of the outlet parcel). During the tank filling process, there is no outgoing flow, and the water age of bottom parcels increases for the time it takes to fill the tank. When the tank is emptied, there is no incoming flow, resulting in a drop of water age from 99.5 h to 87.5 h, which is the time it takes to fill the tank, i.e., 12 hours, and it remains constant during emptying because the time it takes for the water to leave the tank is the time it takes for the age of the stored water to increase.

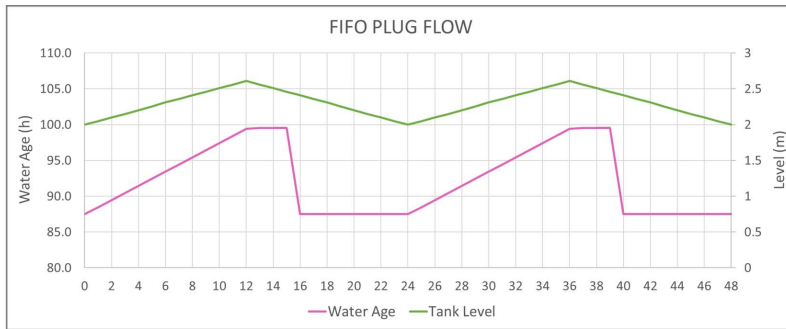

Figure 15. Evolution of water age and tank level. FIFO Plug Flow.

#### LIFO Plug Flow

The behaviour of LIFO Plug Flow is similar to that of FIFO Plug Flow. But in this case water parcels are stacked one on top of the other and the last one to enter the tank is the first to leave. In the case of vertical stratification, it would correspond to filling and emptying the tank from the bottom.

To better understand the behaviour of the LIFO plug flow model, the scheme presented in Figure 16 shows the water age evolution of the parcels inside the tank, starting from a full tank and fixed time steps of 1 h.

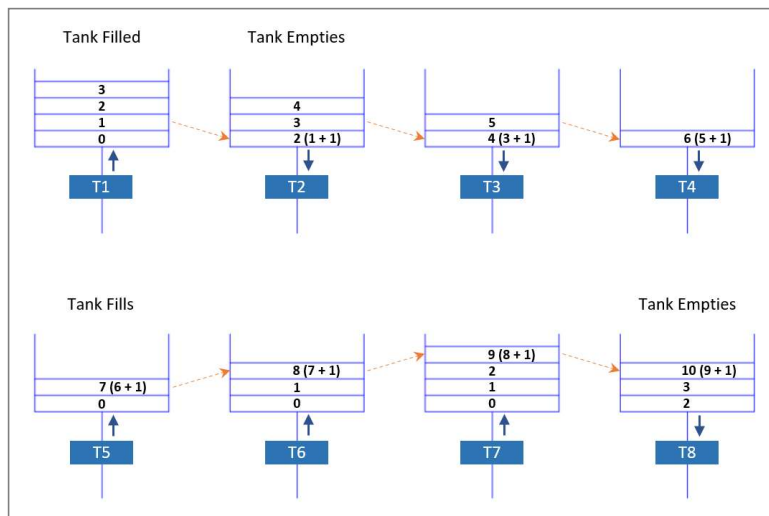

Figure 16. Evolution of water age in the parcels of the tank. LIFO Plug Flow. Numbers on parcels stand for the water age, in h. Each figure represents the evolution of parcels for a time step of 1 h.

As the tank empties, the stored parcels age at a rate of 1 h at each time step. Thus, the lowest parcel (whose value is that provided by Epanet) ages at a rate of 2 h.

In addition, as the tank fills, new water with a low water age enters the tank, creating the lower parcels with a sudden decrease in the water age simulation results. Meanwhile, the water stored in the upper parcels ages at each time step, resulting in an abrupt increase in water age when the tank begins to empty.

Note that under normal conditions, where there is always some reserve volume stored in the tanks, the upper parcels never leave the network nor mix with other parcels and continue to age at each simulation time step, reaching high water age values up to the total simulation time.

Figure 17 shows the simulation results, where water age decreases abruptly to zero when the tank is being filled, as new water enters the tank and fills the lower parcel. Conversely, when the tank empties, the water age doubles the real time because the old water stored in the upper lagged parcels exits as it becomes older. At the end of the emptying cycle, there is a peak in water age that corresponds to the upper parcels that were never renewed. In fact, this is due to mass imbalances that occurred during the implementation of the quality model in Epanet.

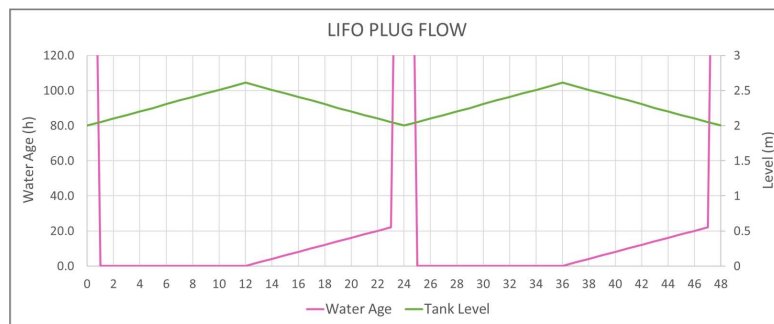

Figure 17. Evolution of water age and tank level. LIFO Plug Flow.

#### 4.2. Case Study 2

Figure 18 shows the network for Case Study 2, which is similar to Case Study 1. However, in this case, the tank has two independent connection pipes. Therefore, all demand flow enters the tank before exiting to the network, and incoming and outgoing flow can overlap.

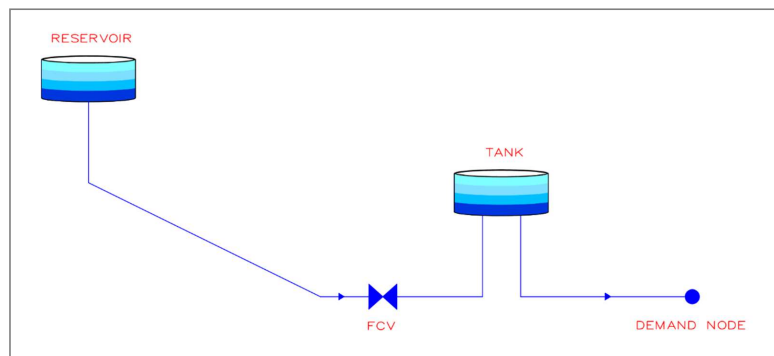
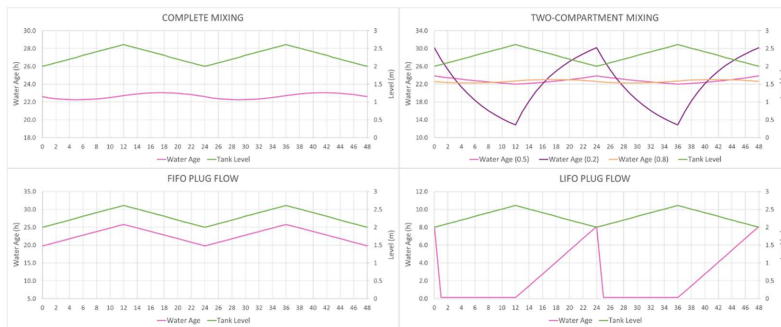

Figure 18. Case Study 2 network diagram.

The hydraulic behaviour is similar in both cases, but not the quality behaviour. The detailed analysis of WQ behaviour in each case would be carried out following the same steps as shown for case study 1. But it is important to note that the daily water renewal rate in Case Study 2 is much higher, at 52.68 %, thus in general terms, water age in Case Study 2 will be lower in general than in Case Study 1, being the results shown in Figure 19.

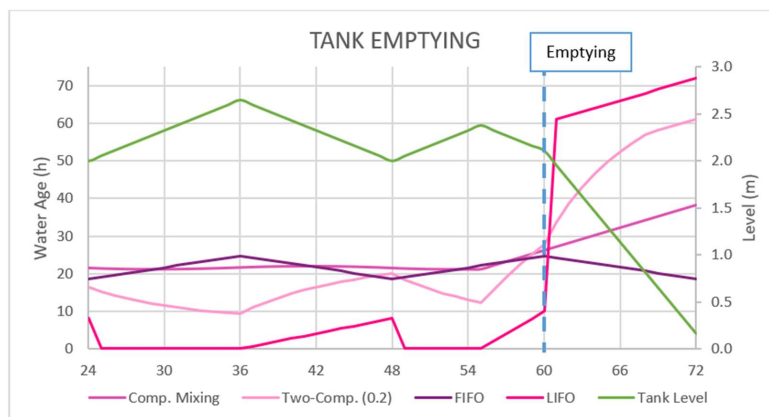

**Figure 19.** Evolution of water age and tank level for all four Epanet tank mixing models. Independent I/O pipes.

#### 4.3. Revealing the Quality of Water Inside the Tank

As stated before, Epanet provides the water age in the storage tanks as the water age at the tank outlet. Therefore, the total average water age of the volume stored within the storage tank is unknown, except for the complete mixing model.

One way to get a rough idea of the quality of the water in the different compartments or parcels inside the tank is to cause the tank to be emptied cancelling the inflow. Figure 20 illustrates the evolution of water age for different mixing models as the tank empties.



**Figure 20.** Evolution of water age when the tank empties.

For the Complete Mixing model, the water age calculated in Epanet at the tank outlet coincides with the average water age of the entire volume of water within the tank and so the water age increases linearly as the tank empties.

The Two-Compartment Mixing model operates in two stages. In the first stage, the first compartment with the lower water age begins to empty and the water from the second compartment fills the left volume of the first compartment, so that the water age increases abruptly. In the second stage, once the second compartment empties, all volume with higher water age remains exclusively in the first compartment, and there is no further mixing between volumes with high and low water age, resulting in a softening of the line slope.

The FIFO Plug Flow has a decreasing water age during emptying, as expected from the study of the behaviour of this model. This is due to the fact that water exits the tank at a faster rate than it entered, so the water age decreases.

The LIFO Plug Flow exhibits an abrupt increase in water age when the tank empties. This is because the stored water in the tank ages without being renewed, and when the tank empties, all of that volume exits, resulting in an increase in water age.

## 5. Field Tests

Determining the mixing that best represents a real tank behaviour can be done by following the evolution of a tracer injected into the tank [31]. The tracer can be controlled at both the inlet and outlet of the tank. When dealing with non-reactive materials, intermittent injection is sufficient as there will be no reaction over time. On the other hand, the tracer can be a reactive substance that undergoes decay or growth while remaining in the tank. By monitoring the concentration at the tank outlet, it is possible to determine the evolution of the substance inside the tank and, consequently, the most suitable mixing model to match reality.

Continuous monitoring of chlorine residuals concentration is common in many WDNs. In this way, following the chlorine evolution at tank's inlet and outlet permits to choose the Epanet mixing model that reproduces reality with higher accuracy.

### 5.1. Description of the Facilities

The drinking water supply system of the study includes several tanks. The following analysis was carried out in one of these tanks, whose configuration is shown in Figure 21.

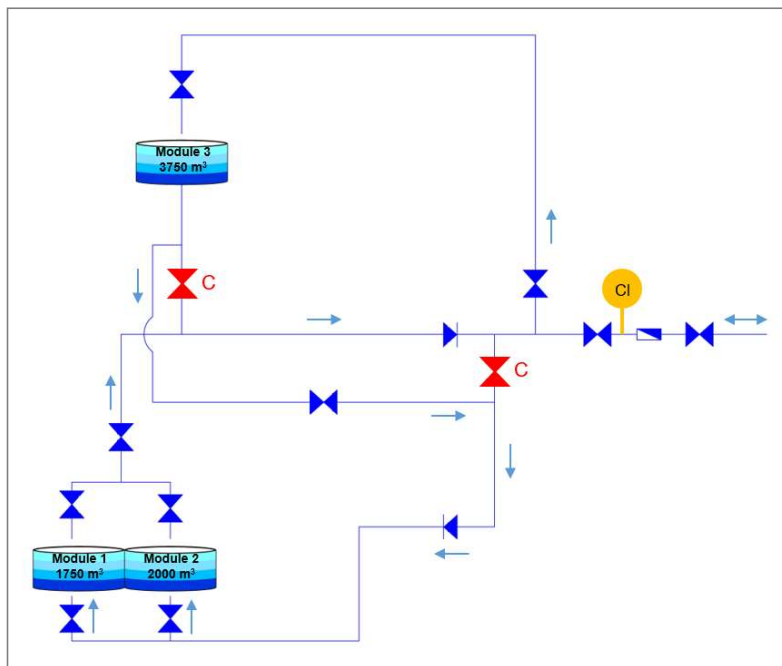

Figure 21. Tank configuration (plant view).

The tank operates by creating a sequential circulation circuit. Water first enters Module 3, which has the highest capacity, from the bottom right and exits the tank from the bottom left. It then flows in parallel to Modules 1 and 2, entering from the bottom and exiting from the opposite bottom side. The modules are connected to the network through a single pipe, allowing water to enter or leave the modules compound, but never at the same time. A chlorine sensor is located at the point where the set of tank connects to the network.

A priori, given the tank configuration, it is not clear which mixing model would be the most appropriate. Under ideal operating conditions, the system exhibits FIFO behaviour. However, in more realistic scenarios, water flows with different ages may interact, so Complete Mixing or Two-Compartment Mixing may be more appropriate. Furthermore, due to the close proximity of the inlet and outlet pipes, a short-circuit may occur at the bottom of the modules. This could cause water to remain on the upper side of the tank for longer periods, resulting in a LIFO model.

As previously noted, reality is much more complex, and the behaviour of a real tank may be a combination of these theoretical models. However, to integrate tanks into a complete WQ model of the entire network, it is necessary to determine through experimental measurements which Epanet simplified model best represents reality.

On average, the tank demand is 19.85 l/s, with a regulating volume of 1,715 m<sup>3</sup> when three modules are operating. Additionally, there is a reserve volume of 2,465 m<sup>3</sup> to ensure supply security. Figure 22 displays the level evolution and inlet/outlet flows for the tank's module set over a 48-h interval.

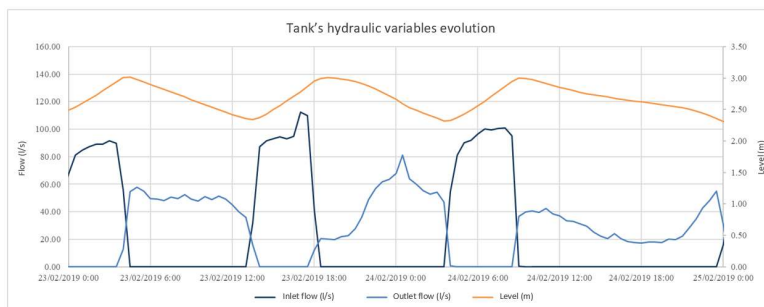

**Figure 22.** Evolution of the tank level, inlet and outlet flows.

The graph illustrates that the filling and emptying regimes are clearly differentiated due to the single pipe connection to the network.

The field tests carried out consisted of making the various modules independent and characterising their behaviour from the point of view of WQ. Figure 23 presents the operation schemes that governed the field test.

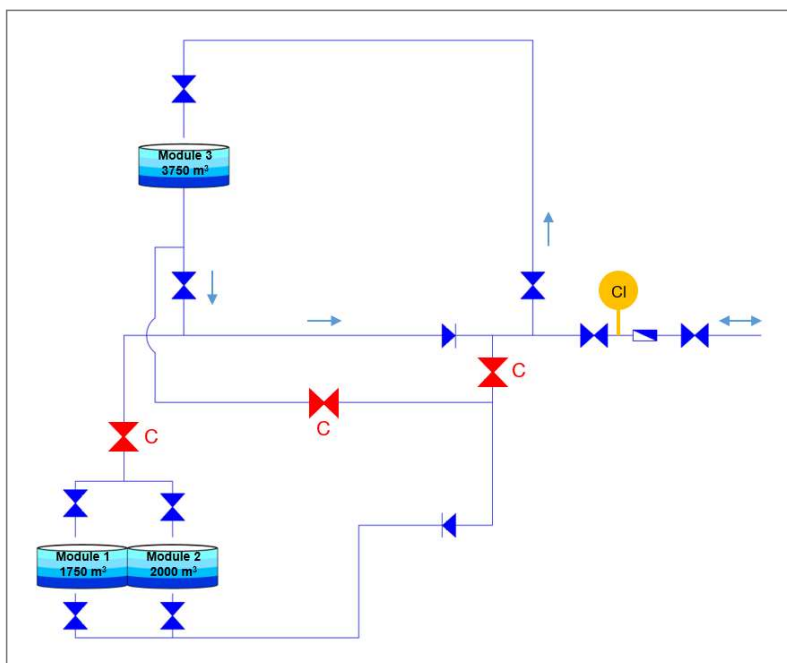

**Figure 23.** Tank configuration when performing the field tests. Modules 1 and 2 are isolated.

### 5.2. Determination of Chlorine Bulk Coefficient

To model the behaviour of the tank, it is necessary to first determine the bulk coefficient that governs chlorine decay.

The laboratory obtained the bulk coefficient of chlorine from six samples taken from two points, A and B, located in the transport pipe connecting the tank to the network. Three samples were taken from each point, and they were kept at a constant temperature of 20 °C. The chlorine concentration was periodically measured, and the measurements were validated using two different sampling equipment.

The evolution of chlorine concentration follows a first-order decay, as described by Levenspiel in 1999.

$$C = C_0 \cdot e^{-K \cdot t} \quad (3)$$

being  $K$  the chlorine bulk reaction rate and  $C_0$  the initial chlorine concentration.

The relation between chlorine concentration and water age for the samples taken at 20 °C is presented in Tables 2 and 3.

Table 2. Chlorine decay over time in sample A.

TIME (h)	POINT A			POINT A			AVERAGE C(t)
	Sampling equipment 1			Sampling equipment 2			
	PA-S1	PA-S2	PA-S3	PA-S1	PA-S2	PA-S3	
0	0.99	0.95	0.93	0.91	0.95	0.93	0.943
1	0.94	0.93	0.92	0.97	0.96	0.97	0.948
2	0.98	0.94	0.88	0.98	0.96	0.95	0.948
3	0.92	0.89	0.86	0.99	0.96	0.95	0.928
4	0.96	0.92	0.92	0.99	0.94	0.93	0.943
5.5	0.91	0.92	0.9	0.92	0.92	0.87	0.907
7	0.9	0.92	0.9	0.91	0.89	0.86	0.897
23.5	0.81	0.77	0.68	0.76	0.77	0.71	0.750
31.5	0.6	0.59	0.57	0.58	0.56	0.56	0.577
119.5	0.22	0.17	0.21	0.20	0.11	0.22	0.188
149.5	0.11	0.08	0.15	0.13	0.05	0.15	0.112

Table 3. Chlorine decay over time in sample B.

TIME (h)	POINT B			POINT B			AVERAGE C(t)
	Sampling equipment 1			Sampling equipment 2			
	PB-S1	PB-S2	PB-S3	PB-S1	PB-S2	PB-S3	
0	0.98	1.04	1.00	1.02	1.06	1.03	1.02
1	0.99	1.00	0.98	-	1.00	1.04	1.00
2	0.90	0.93	0.92	1.01	1.01	1.01	0.96
3	1.01	0.90	0.93	1.02	0.94	0.98	0.96
4.5	0.98	1.00	0.93	0.98	0.95	0.98	0.97
6	0.91	0.98	0.92	0.96	0.96	0.95	0.95
22.5	0.71	0.75	0.81	0.75	0.78	0.79	0.77
30.5	0.67	0.59	0.64	0.75	0.57	0.58	0.63
118.5	0.18	0.07	0.15	0.10	0.13	0.17	0.13
148.5	0.08	0.09	0.11	0.11	0.08	0.10	0.10

By representing the results in a logarithmic base, a line is obtained whose slope corresponds to the bulk coefficient K. In this way, the bulk coefficient of chlorine determined is  $0.0145 \text{ h}^{-1}$ , which is similar for the two measurement points.

### 5.3. Experimental Assessment of the Evolution of Chlorine at the Tank Inlet/Outlet Pipe

The chlorine evolution in the tank was experimentally determined by isolating Module 3 in the first phase. Module 3 has a higher capacity of  $3,750 \text{ m}^3$  and was used to obtain the chlorine concentration at the outlet of Module 3, which in a second phase will be the inlet of Modules 1 and 2 from which water returns to the network. The evolution of chlorine in Modules 1 and 2, which are located in parallel with volumes of  $1,750 \text{ m}^3$  and  $2,000 \text{ m}^3$  respectively, was finally obtained.

Figure 24 presents the results obtained for Module 3 over a 24 h period starting on 06/17/2019 at 00:00.

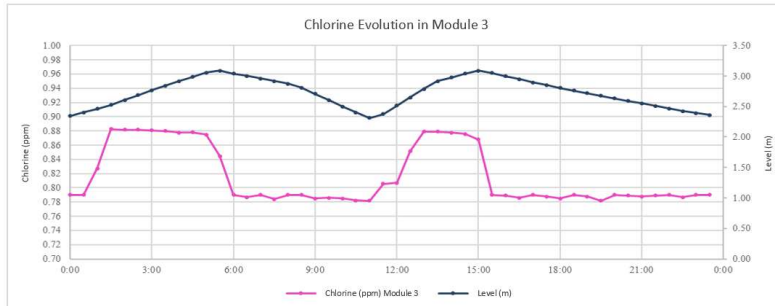

Figure 24. Tank level and chlorine evolution in Module 3.

The graph illustrates that during the filling of the tank, water with a lower water age is introduced, so that the chlorine measurements increase up to 0.9 ppm. Conversely, when the tank is being emptied, chlorine measurements decrease abruptly to 0.8 ppm due to the increase in water age after being stored inside the tank, resulting in a decrease in chlorine values.

It is important to note that the field tests were conducted in accordance with the tank's operational rules. It was not possible to extend the field tests in order to preserve the WQ in Modules 1 and 2, trying not to significantly increase the water age in them. Therefore, the field tests were conducted on three alternate days to assess the repeatability of the results without affecting the normal system operation.

The analysis of Module 3 indicates that the chlorine value decreases by approximately 0.1 ppm compared to the input value. No fluctuations were observed, resulting in a constant chlorine value.

After studying Module 3 independently, the chlorine evolution at the pipe connection to the rest of the network was analysed with all modules in operation in order to characterise the chlorine evolution at Modules 1 and 2.

Figure 25 shows that in this case, chlorine evolution follows a similar trend to that of Module 3. However, the decrease in chlorine is higher as the storage volume and water age increase.

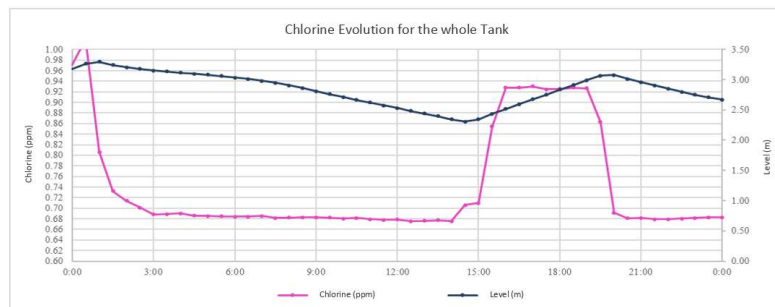

Figure 25. Tank level and chlorine evolution with all three modules operating.

The experimental analysis indicates that when all three modules are operating, chlorine is reduced by approximately 0.25 ppm, of which 0.1 ppm is reduced in Module 3 and 0.15 ppm in modules 1 and 2.

The larger decrease in chlorine concentration observed in Modules 1 and 2 may be due to the simplified internal configuration assumed, resulting in a 3,750 m<sup>3</sup> module with baffles. Guiding baffles reduce stagnation zones and promote higher stored volume renewal, thereby decreasing the total water age of all stored volume. However, since it takes more time to renew a higher volume, an

increase in water age at the tank outlet is observed, resulting in a higher decrease in chlorine concentration.

#### 5.4. Epanet Modelling

The purpose of modelling the tank behaviour with Epanet is to analyse theoretically the water age and chlorine evolution inside the tanks and to compare the results obtained with experimental measurements in order to determine the Epanet mixing model that better simulates the observed measurements and to confirm whether or not this model matches the model derived from the physical tank characteristics, including the baffles inside Modules 1 and 2.

Figure 26 illustrates the chlorine evolution and tank level for a 48-hour simulation using Epanet, for Module 3 and all available mixing models.

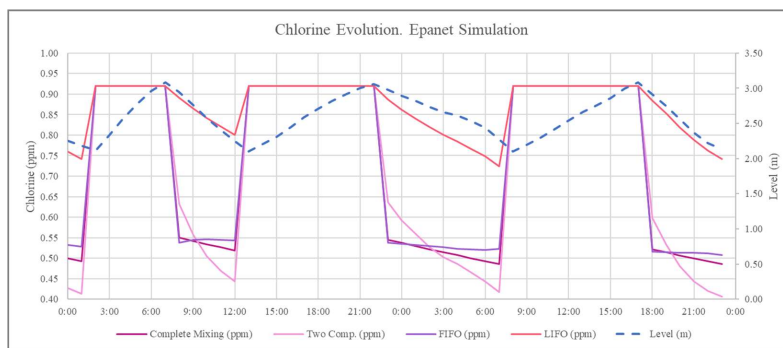

**Figure 26.** Simulated chlorine evolution for all mixing models available in Epanet.

The tank behaviour with the three modules was simulated using Epanet to determine the mixing model that best represents reality. Since Modules 1 and 2 together have similar characteristics to Module 3, the results obtained are comparable to those of Module 3 alone.

## 6. Discussion

To determine the mixing model that best represents reality, the decay amount and the trend of this decay were considered.

Firstly, it is important to note that the simulated chlorine decay for Complete Mixing, Two-Compartment Mixing, and FIFO Plug Flow is significantly higher than that observed in field tests. During the experimental phase, a decay of 0.1 ppm was observed, while the simulations resulted in a decay of approximately 0.35 ppm. This indicates a significant difference between the models and reality. Additionally, the simulated and observed chlorine decay for the LIFO Plug Flow model is similar, 0.1 ppm. Regarding the decay amount, LIFO Plug Flow better reproduces reality. This means that as the tank fills and empties from the bottom, only the lower part of the tank is renewed, resulting in stratification in the upper part.

Regarding the decay trend, for Complete Mixing, Two-Compartment Mixing, and LIFO Plug Flow, the simulation of chlorine decay shows a descending trend during emptying, which does not correspond to reality. However, FIFO Plug Flow presents continuous values during emptying, without fluctuations, which matches the results observed in field tests. Therefore, in the lower part of the tank, there is an area that behaves like FIFO Plug Flow.

Thus, it can be concluded that the tank's behaviour matches the FIFO Plug Flow model with stagnation in the upper part of the tank. Figure 27 illustrates this behaviour, with stratification in the upper section and FIFO Plug Flow behaviour in the lower section, where water enters from one side and moves in an orderly manner to the outer section. Unfortunately, this combined model is not

currently offered by Epanet, which could be an important improvement for the future given the experimental results observed in our case study.

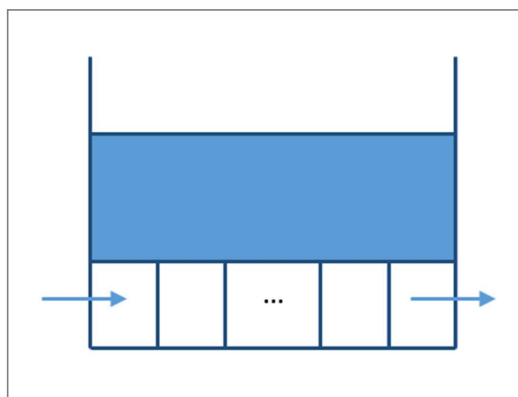

Figure 27. Schematic of the proposed mixing model.

## 7. Conclusions

As reviewed in this work, storage tanks can have a significant impact on WQ. Therefore, analysing the tank behaviour is crucial during both the design and operation phases.

During the design phase, it is possible to determine the tank configuration and operation that most efficiently preserves WQ. Defining tank configurations with independent inlet/outlet pipes and operations with high daily renewal rates will result in a closer approximation to complete mixing or FIFO behaviours, which is beneficial from a WQ perspective. Additionally, high daily renewal rates result in lower retention times, which is also beneficial for preserving WQ. However, it is important to note that this approach may not be the best for ensuring a security storage volume.

During operational phases, it is crucial to analyse the behaviour of tanks in terms of WQ to ensure adequate values throughout the network. Modelling tanks in Epanet is useful for incorporating them into a global WQ model of the network and gaining insights into the behaviour of the system. Field tests can also aid in analysing how tanks behave in reality and determining the Epanet mixing model that best reflects reality. Based on the experimental results, for the tank analysed in this study, a Two-Compartment Mixing model appears to be the most suitable. The upper compartment behaves as a Complete Mixing model, while the lower compartment behaves as a FIFO model.

**Author Contributions:** Conceptualization, F.M. and M.H.; methodology, F.M., M.H. and P.C.; validation, F.M., M.H. and P.C.; formal analysis, F.M., M.H. and P.C.; writing—original draft preparation, M.H.; writing—review and editing, M.H., F.M. and P.C.; visualization, M.H. and F.M. All authors have read and agreed to the published version of the manuscript.

**Funding:** This research received not external funding.

**Data Availability Statement:** The data of examples presented in this study are available on request from the corresponding author. The data of experimental case not reported here are not public due to confidentiality reasons since a real network was used as example.

**Conflicts of Interest:** The authors declare no conflicts of interest.

## References

1. Spencer, C. Water quality in the distribution system. A review. *Journal AWWA* **2012**, *104*, 45-55.
2. Grayman, W.; Clark, R.; Harding, B.; Maslia, M.; Aramini, J. Reconstructing Historical Contamination Events. In *Book Water Security and Safety*, McGraw-Hill, 2004, pp 10.2-10.55.

3. Janke, R.; Tryby, M.; Clark, R. Protecting Water Supply Critical Infrastructure: An Overview. In *Book Securing Water and Wastewater Systems Global Experiences*, Springer-Science, 2014, pp 29-85.
4. Grayman, W.; Mahmood, F.; Roberts, M. Water Quality Calibration. In *Book Handbook for Water Distribution Systems Model Calibration*, Ed. Parault, P.; Ziemann, S. AWWA, Denver, CO, 2023, pp 91-111.
5. Hervás, M.; Martínez-Alzamora, F.; Conejos, P.; Alonso, J.C. Advantages of the Event Method for the Simulation of Water Quality in Pressurised Water Systems. *Water* **2024**, *16*, 599. <https://doi.org/10.3390/w16040599>
6. Conejos Fuertes, P.; Martínez Alzamora, F.; Hervás Carot, M.; Alonso Campos, J.C. Building and exploiting a Digital Twin for the management of drinking water distribution networks. *Urban Water Journal* **2020**. <https://doi.org/10.1080/1573062X.2020.1771382>
7. Rossman, L.A.; Woo, H.; Tryby, M.; Shang, F.; Janke, R.; Haxton, T. *EPANET 2.2 User Manual*. Water Infrastructure Division, Center for Environmental Solutions and Emergency Response, U.S. Environmental Protection Agency. Cincinnati, USA, 2020.
8. Vidal, R., Martínez-Alzamora, F., Ayzá, M. Applications of water quality models in water distribution networks simulation (in Spanish). *Ingeniería del agua*, **1994**, *1*(3), 55-68.
9. AWWA. Computer Modeling of Water Distribution Systems. M32 manual. Journal AWWA, 4th Edition. Denver, USA, 2017.
10. Grayman, W. History of water quality modelling in distribution systems. 1st International WDSA/CCWI Joint Conference, Kingston, Ontario, Canada, 2018.
11. Kirmeyer, G.; Friedman, M.; Martel, K.; Noran, P.; Smith, D. Practical guidelines for maintaining distribution system water quality. *Journal AWWA* **2001**, *93*(7), 62-73.
12. Grayman, W.; Deininger, R.; Green, A.; Boulos, P.; Bowcock, R.; Godwin, C. Water quality and mixing models for tanks and reservoirs. *Journal AWWA* **1996**, *88*(7), 60-73.
13. Grayman, W.; Rossman, L.; Arnold, C.; Deininger, R.; Smith, C.; Smith, J.; Schnipke, R. *Water Quality Modeling of Distribution System Storage Facilities*; AWWA Research Foundation: Denver, CO, USA, 2000.
14. Mahmood, F.; Pimblett, J.; Grace, N.; Grayman, W. Evaluation of water mixing characteristics in distribution system storage tanks. *Journal AWWA*, **2005**, *97*(3), 74-88.
15. Akuffo, I.; Cobbina, S. J.; Alhassan, E. H.; Nkoom M. Assessment of the quality of water before and after storage in the Nyankpala Community of the Tolon-Kumbungu District, Ghana. *International Journal of Scientific & Technology Research* **2013**, *2* (2), 221–227.
16. Clark, R. M.; Abdesaken, F.; Boulos, P. F.; Mau, R. E.; Mixing in distribution system storage tanks: its effect on water quality. *Journal of Environmental Engineering* **1996**, *122* (9), 814–821.
17. Edwards, J.; Maher, J. Water quality considerations for distribution system storage facilities. *Journal of the American Water Works Association*, **2008**, *100* (7), 60–65.
18. Kennedy, M. S.; Moegling, S.; Sarikelle, S.; Surava, K. Assessing the effects of storage tank design on water quality. *Journal of the American Water Works Association* **1993**, *85*, 78-88.
19. Pinheiro, A.; Monteiro, L.; Almeida, M.; Covas, D. Water mixing in rectangular storage tanks: small-scale versus field tests. *Journal of Hydraulic Research* **2023**, *61*:2, 233-248, <https://doi.org/10.1080/00221686.2022.2161960>
20. Chalchisa, D.; Megersa, M.; Beyene, A. Assessment of the quality of drinking water in storage tanks and its implication on the safety of urban water supply in developing countries. *Environmental Systems Research* **2018**, vol. 6, p. 1-6. <https://doi.org/10.1186/s40068-017-0089-2>
21. Malinowski, N.; Domingos, S.; Wylie, J.; Morgan, M. J.; Metcalfe, S.; Walsh, T.; Ahmed, W.; Kaksonen, A. H.; Puzon, G. J. Free-living amoeba and associated pathogenic bacteria in well-chlorinated drinking water storage tanks. *ACS ES&T Water* **2022**, *2*(9), 1511-1520.
22. Rossman, L.; Grayman, W. Scale-model studies of mixing in drinking water storage tanks. *Journal of Environmental Engineering* **1999**, *125* (8), 755,761.
23. Pinheiro, A.; Monteiro, L.; Carneiro, J.; Almeida, M.; Covas, D. Water Mixing and Renewal in Circular Cross-Section Storage Tanks as Influenced by Configuration and Operational Conditions. *Journal Hydraulic Engineering* **2021**, *147*(12), 04021050. [https://doi.org/10.1061/\(ASCE\)HY.1943-7900.0001955](https://doi.org/10.1061/(ASCE)HY.1943-7900.0001955)
24. Tian, X.; Roberts, P. J. Mixing in water storage tanks. I: no buoyancy effects. *Journal of Environmental Engineering* **2008**, *134* (12), 974-985.
25. Sauner, J.; Maslia, M.; Grayman, W. Storage tank mixing models: comparison of tracer data with model simulation. In *World Environmental and Water Resources Congress: Restoring Our Natural Habitat*, Tampa, Florida, USA, 2007; pp. 1-11
26. Abrha, B.; Ostfeld, A. Analytical Solutions to Conservative and Non-Conservative Water Quality Constituents in Water Distribution System Storage Tanks. *Water* **2021**, *13*, 3502. <https://doi.org/10.3390/w13243502>
27. Grayman, W.; Arnold, C. Overview of CFD methods in analysis of distribution system tanks and reservoirs. Proceedings, AWWA Annual Conference, Anaheim, California, USA, 2003.

28. Gualtieri, C. Analysis of flow and concentration fields in a baffled circular storage tank. 33rd IAHR Congress: Water engineering for a sustainable environment, 2009.
29. Fard, M. A.; Baruah, A.; Barkdoll, B. D. CFD modeling of stagnation reduction in drinking water storage tanks through internal piping. *Urban Water Journal* **2021**, *18*(8), 608-616, <https://doi.org/10.1080/1573062X.2021.1918184>
30. Ormsbee, L.; Wood, D.; Identification of supply source percentages and water age using KYPIPE and KYFSI. AWWA Annual Conference, Cincinnati, Ohio, USA, 1991.
31. Grayman, W.; Rossman, L.; Deininger, R.; Smith, C.; Arnold, C.; Smith, J. Mixing and aging of water in distribution system storage facilities. *Journal AWWA* **2004**, *96*(9), 70-80.

**Disclaimer/Publisher's Note:** The statements, opinions and data contained in all publications are solely those of the individual author(s) and contributor(s) and not of MDPI and/or the editor(s). MDPI and/or the editor(s) disclaim responsibility for any injury to people or property resulting from any ideas, methods, instructions or products referred to in the content.