

Article

Not peer-reviewed version

Development of Self-generated and LPWA-based Crop Growth Environment Monitoring and Bigdata Analysis System

[YeonJae Oh](#)*

Posted Date: 6 December 2023

doi: 10.20944/preprints202312.0410.v1

Keywords: smart farm; field crop growth environment monitoring; bigdata analysis; low power wide area(LPWA); one machine to machine(oneM2M),



Preprints.org is a free multidiscipline platform providing preprint service that is dedicated to making early versions of research outputs permanently available and citable. Preprints posted at Preprints.org appear in Web of Science, Crossref, Google Scholar, Scilit, Europe PMC.

Copyright: This is an open access article distributed under the Creative Commons Attribution License which permits unrestricted use, distribution, and reproduction in any medium, provided the original work is properly cited.

Article

Development of Self-Generated and LPWA-Based Crop Growth Environment Monitoring and Bigdata Analysis System

Yeon-Jae Oh

Department of Computer Engineering, Artificial Intelligence Major, Suncheon National University, Suncheon, 57952, Korea; oksug10@snu.ac.kr

Abstract: Smart farm is a technology that greatly helps improve the productivity and quality of crops and is being actively introduced into indoor environments such as green houses. However, it has not yet been distributed to field-grown crops. The main reason is that, unlike indoor environments, it is very difficult to collect sensor data for monitoring the growth environment of crops in open fields where weather conditions change significantly and power supply is difficult. Additionally, because various sensors are used, the data formats of the devices are different, making it difficult to process. This paper presents a field crop growth environment monitoring and big data analysis system. The proposed system first solves power supply and data communication problems using solar power generation and LPWA technology. Additionally, based on the oneM2M architecture, data from various sensors is transmitted to the server using standardized technology. The transmitted data is stored and managed on the server as big data, and can be used to predict the production and quality of field-grown crops and take appropriate measures. The proposed system is expected to create an environment optimized for the growth of field crops and help prevent and manage diseases.

Keywords: smart farm; field crop growth environment monitoring; bigdata analysis; Low Power Wide Area (LPWA); One Machine to Machine (oneM2M)

1. Introduction

Smart farm is a system that utilizes information and communication technology in the agricultural field to improve productivity and stably manage the quality and quantity of crops, and is being actively introduced to indoor environments such as green houses [1–4]. In the green house, sensor data such as temperature, humidity, CO₂, soil moisture, and pH can be easily collected through wired or short-distance wireless communication to monitor crop growth. However, it is difficult to collect sensor data using these communication methods in large open areas where weather conditions change significantly and power supply is limited. In addition, there are many limitations in controlling the growth environment of crops because it is difficult to operate irrigation and nutrient solution supply devices. Due to these problems, smart farms for field crops require self-power supply and LPWA (Low-Power Wide-Area) wireless communication technology. LPWA communication technology is a network technology designed for low-power, long-distance communication and is mainly used to transmit small amounts of data such as sensor data and monitoring information at low power [5–8]. LPWA communication encompasses several protocols and technologies. For example, there are Narrowband Internet of Things (NB-IoT), Long Term Evolution for Machines (LTE-M), and Long Range Wide Area Network (LoRa WAN), and each technology is selected according to specific uses and requirements. Combining a self-generating system with LPWA communication technology can provide an efficient and economical solution for collecting and transmitting data in outdoor environments. This can be used in various application fields such as sensor data collection in remote areas, energy monitoring, and environmental monitoring.

Also, a standardized platform such as oneM2M is essential to respond to various types of sensors for monitoring the outdoor cultivation environment. oneM2M is a standardized platform for Internet-based M2M (Machine-to-Machine) communication. It can provide a variety of services by efficiently collecting, storing, and analyzing data generated from various devices and networks. Additionally, oneM2M provides interconnectivity between IoT devices and enables automated control and monitoring through communication between devices.

This paper presents a field crop growth environment monitoring and big data analysis system. The proposed system first solves power supply and data communication problems using solar power generation and LPWA technology. Additionally, based on the oneM2M architecture, data from various sensors is transmitted to the server using standardized technology. The transmitted data is stored and managed on the server as big data, and can be used to predict the production and quality of field-grown crops and take appropriate measures. The proposed system is expected to contribute to the production of low-cost, high-quality field crops through the convergence of renewable energy and smart farms, and can be applied to other industrial fields that monitor the growth environment of crops in the field and utilize the oneM2M architecture.

The structure of this paper is as follows. Section 2 describes LPWA communication technology and oneM2M platform, and Section 3 describes the proposed LPWA-based field crop growth monitoring and big data analysis system. Section 4 presents the implementation results of the proposed system, and Section 5 concludes.

2. Related Works

2.1. LPWA

LPWA stands for Low Power Wide Area and is a low-power, wide-range communication technology. LPWA is mainly used to communicate with IoT devices and has characteristics such as low power consumption, wide coverage, and low cost [9,10]. LPWA is primarily used to communicate with small-scale IoT devices such as sensors, monitoring devices, smart meters, etc [11]. These devices have low power consumption and slow data transfer rates, but require the ability to connect large numbers of devices at once. LPWA is a technology developed to meet these requirements. LPWA services currently available include NB-IoT (Narrowband IoT), LoRa WAN provided by the LoRa alliance, and LTE-M (Long Term Evolution for Machines). The following table shows the LPWA technologies of NB-IoT, LTE-M, and LoRa WAN [12–18].

Table 1. Comparison of LPWA technologies.

Technology	NB-IoT	LTE-M	LoRa WAN
Frequency band	Licensed bands	Licensed bands	Unlicensed bands
Transfer speed	250 kbps	1 Mbps	0.3~50 kbps
Coverage	Good	Good	Very excellent
Power Consumption	Very low	Low	Very low
Cost	Relatively high	Relatively high	Relatively low
Compatibility	Compatible with existing mobile communication networks	Compatible with existing mobile communication networks	Not compatible with existing mobile networks

NB-IoT uses licensed bands, and although the transmission speed is relatively slow, it has good coverage and power consumption. LTE-M uses licensed bands and has fast transmission speeds but relatively high-power consumption. LoRa WAN uses unlicensed radio frequency bands and has low transmission rates but very good coverage and power consumption [19]. In terms of cost, LoRa WAN can be implemented at relatively low cost. Considering these characteristics, the system presented in this paper constructed a communication network using LoRa WAN.

2.2. oneM2M

oneM2M is a standard jointly developed by international standardization organizations such as ITU, ETSI, TTA, and ARIB, and provides a standardized interface by integrating various network technologies and protocols [20]. oneM2M allows various IoT devices to interconnect and exchange data in a standardized way. In addition, oneM2M provides functions such as security, privacy protection, and device management to ensure the stability and reliability of the Internet of Things system. Due to these advantages, it is used in various industrial fields of the Internet of Things, especially playing an important role in fields such as smart cities, smart homes, smart grids, and smart farms [21–23].

While existing IoT services are comprised of separate platforms, oneM2M supports a variety of services by integrating them into one service platform. Figure 1 shows the difference between the existing platform and the oneM2M platform.

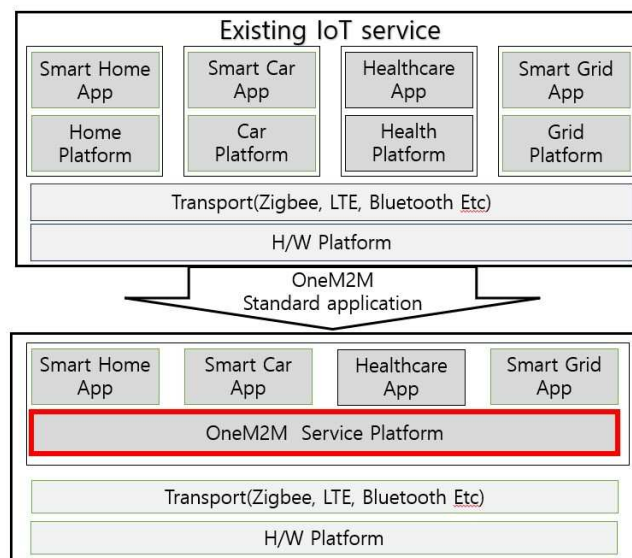

Figure 1. Difference between the existing IoT service and the oneM2M based IoT service.

oneM2M consists of NSE(Network Services Entity), CSE(Common Service Entity), and AE(Application Entity), and the functions provided by the platform are defined as CSF(Common Service Function). Each entity communicates through a reference point.

The main purpose of OneM2M Release 2 is to interoperate with various industrial IoT platforms and networks, and it provides interconnection specifications with AllJoyn and OCF (Open Connectivity Foundation) LWM2M (Lightweight M2M) technology for the purpose of interoperating with the IoT. Additionally, for network interoperability, a traffic pattern configuration function for interoperability with 3GPP Rel-13 network is defined [24]. oneM2M Release 3 derives requirements to support domains such as smart factories and autonomous vehicles and provides standard functions for these [25]. In particular, support for mobile IoT devices has been strengthened.

oneM2M Release 4 is a standard that supports various vertical industries such as Smart-X(city, health, transportation, factory) and disaster safety, and consists of 24 detailed specifications and 4 technical reports [26]. It also includes 5G network interconnection and the latest edge computing technology. By providing SDT(Smart Device Template) 4.0, which guarantees interconnection and compatibility with various smart devices, it makes it possible to provide an IoT digital convergence platform in various vertical industries.

Table 2. Entities in oneM2M.

Entity	NSE	CSE	AE
Role	Provides oneM2M network service	Provides oneM2M's core services	Communicate with oneM2M applications
Function	Network connection management Authentication and Security Data transfer and routing Network status monitoring	Resource management Data storage and retrieval Service control Management of event and alarm	Interface with applications Resource creation and management Send and receive data Receive events and notifications
Example	MQTT broker CoAP server	Database Web server	Control application

3. Crop Growth Environment Monitoring and Bigdata Analysis System

3.1. Crop Growth Environment Sensor Node

To collect field crop growth environment data, we designed a sensor node that generates self-power using solar energy. Sensing items consist of meteorological data of temperature, humidity, wind direction, wind speed, solar radiation, and rainfall, and soil environmental data of soil temperature, soil humidity, and EC(Electrical Conductivity). Figure 2 shows the hardware circuit diagram of the sensor node and the specifications of the sensors are listed in Table 2.

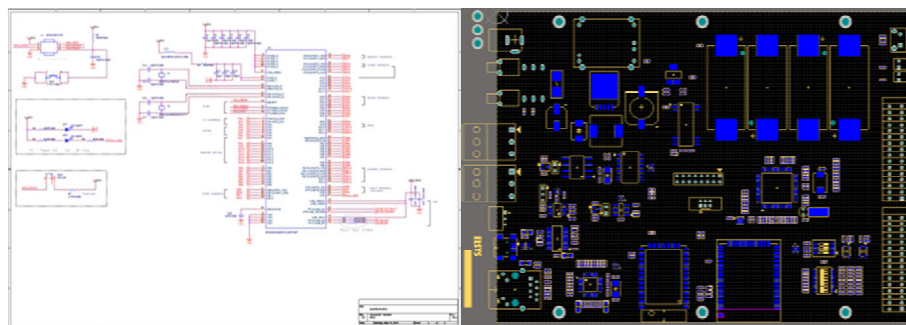
**Figure 2.** The hardware circuit diagram of sensor node.**Table 2.** Environment Sensor specifications.

Environment	Sensor type	Specifications	
		Measure range	Precision
Air environment	Wind speed	1~54 m/s	1 m/s or 5%
	Wind direction	0 ~ 360°	7°
	Temperature	-40 ~ 65 °C	0.5 °C
	Humidity	0 ~ 100%	3% RH
	Rainfall volume	0 ~ 9999mm	4%
Soil environment	Radiation	0 ~ 1800 W/m ²	5%
	Humidity	0 ~ 99.9%	1%
	Soil temperature	0 ~ 66 °C	0.5%
	EC	0 ~ 6.0 dS/m	0.1 dS/M

Since the cultivation environment is outdoors rather than indoors, a long-distance, low-power communication module that supports dust and moisture prevention was designed. As a wireless communication technology, LoRa WAN was selected among LPWA technologies considering

frequency band, cost, coverage, and power consumption. The sensor node was designed to enable low-power, long-distance communication by connecting the SX1276 chip that supports LoRa wireless communication and the STM32 MCU. The hardware block diagram of the sensor node is shown in Figure 3 below.

In addition, it is equipped with a small solar panel, battery, and charge/discharge control module to enable its own power supply.

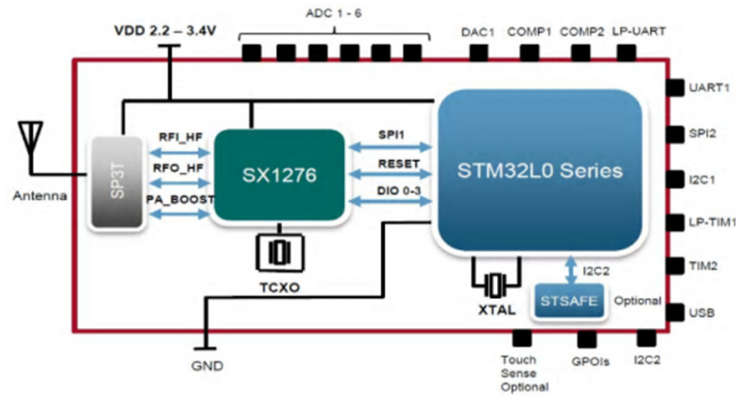

Figure 3. The hardware block diagram of sensor node.

3.2. Gateway

Air and soil environmental data collected by sensor nodes are transmitted to the gateway through the LPWA communication module. The gateway processes the received data and transmits it to the server. At this time, the oneM2M platform is utilized to transmit data in various formats. The hardware block diagram of the gateway equipped with the oneM2M platform are shown in Figure 4 below.

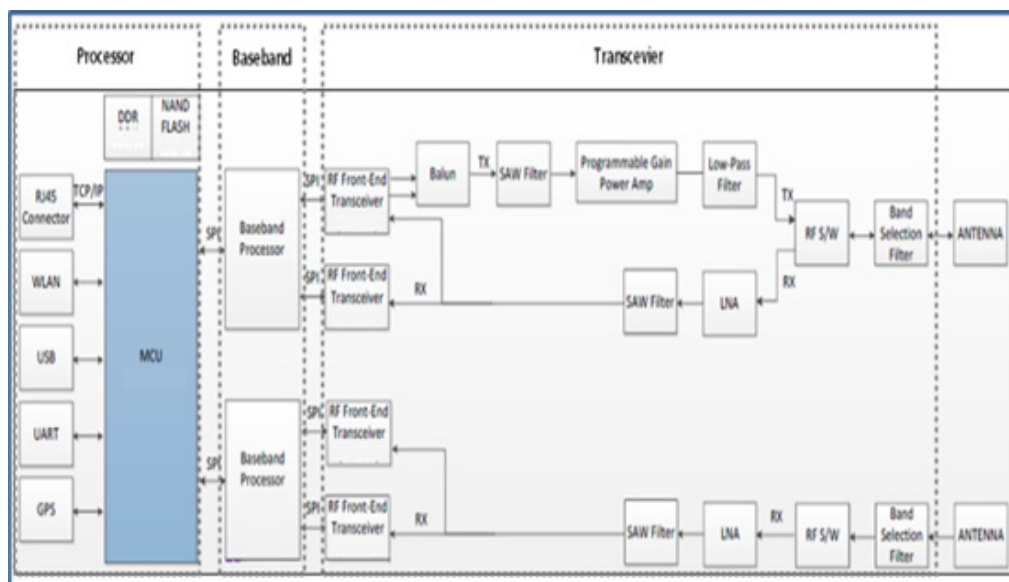

Figure 4. The hardware block diagram of gateway.

The hardware structure of the gateway uses two basebands to communicate with multiple end devices. The master part performs transmission/reception with the upper server, gateway control function, reception for eight reception channels, and transmission/reception functions, and the slave part is designed to only be responsible for reception for eight reception channels. Figure 5 shows the function configuration diagram of gateway.

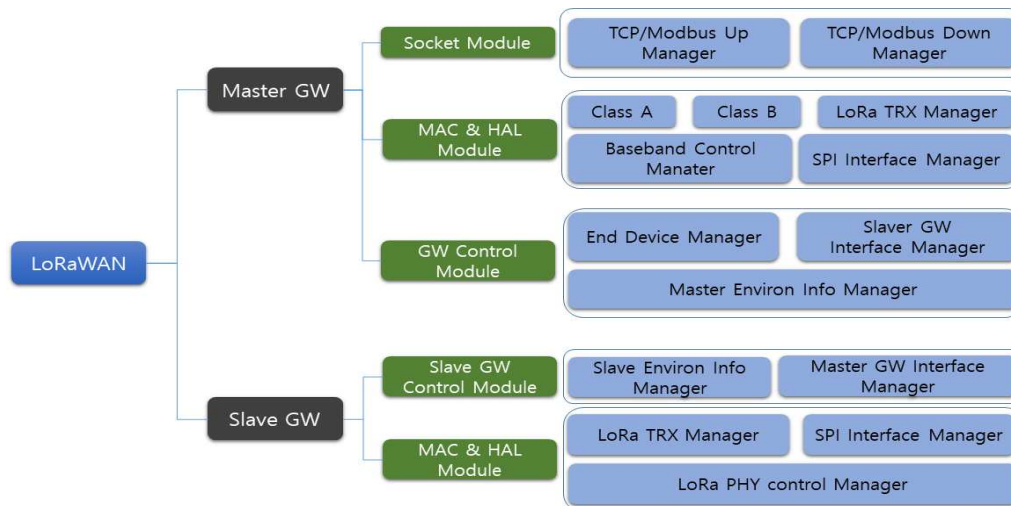

Figure 5. The function configuration diagram of gateway.

The gateway master part consists of a Socket Module for TCP/Modbus communication with the upper server, a GW Control Module for setting and controlling the gateway environment, and a LoRa TRX Manager for transmitting and receiving using LoRa WAN with the end device.

The gateway slave part consists of a slave part control module and MAC & HAL module. First, the sleeve control module manages the interface and settings with the master unit. The MAC & HAL module consists of a LoRa TRX Manager to process LoRa packets received from sensor nodes, a LoRa PHY control manager, and an SPI interface manager to control the LoRa chip.

3.3. Bigdata analysis system

We designed a bigdata analysis system that can reliably process various types of sensing data transmitted from a oneM2M-based gateway. The configuration diagram of the designed data analysis system is shown in Figure 6 below.

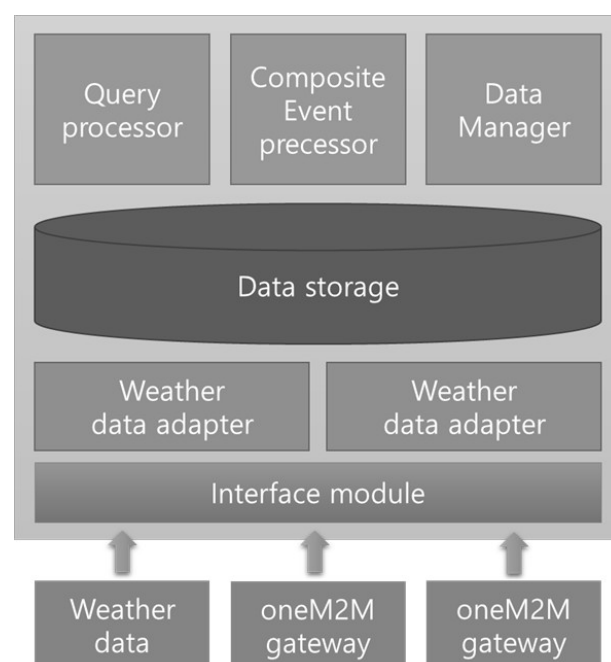

Figure 6. The structure diagram of bigdata analysis system.

It receives data transmitted from the gateway through the environmental information collection standard interface, parses the data received through the external weather data adapter and the ground/soil environmental information adapter, and checks whether the data is correct. The data through the adapter is built as big data in the storage, and the user's query is processed through the environmental information query processor to provide analyzed information.

4. Implementation Results

To evaluate the performance of the proposed LPWA-based plantation growth environment data collection system, a native Actinidia plantation site was selected and a sensing network was constructed to collect LoRa-based micrometeorological and soil environment data. In order to collect various micro-meteorological and soil environment data on native Actinidia cultivation areas, we selected sunny areas with a lot of sunlight, areas with moderate amounts of sunlight, and shaded areas, reflecting the characteristics of the cultivation areas, and compared the correlation between environmental factors and quality within the orchard. The data collection device was installed as shown in Figure 6. The installed data collection device collects temperature, humidity, wind direction/speed, rainfall, solar radiation, ground temperature, humidity, and EC data.



Figure 7. Sensor node.

Sensor nodes collect air environment data and soil environment data and transmit them to the oneM2M-based gateway. The gateway installed in the plantation supports dustproofing and waterproofing and is implemented as shown in Figure 8.



Figure 8. Gateway implementation results.

The LoS test results in the LoRa-based sensing network showed good data transmission reliability and speed up to 2km, and although the data transmission speed slowed down at a distance of 3km, it was possible to collect a small amount of data from IoT-based sensor devices.

A harvest and quality prediction system for forest products was implemented using stored data. The plantation area where the system was installed was an Actinidia plant, and prediction of Actinidia yield and sugar content was performed using data collected. Figure 9 and 10 shows the predicted results of analyzed Actinidia yield and sugar content.

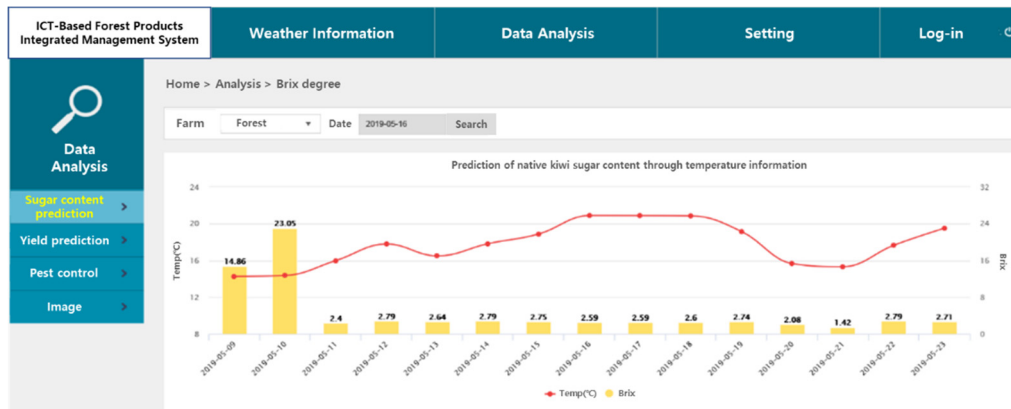

Figure 9. Kiwi sweetness prediction result.

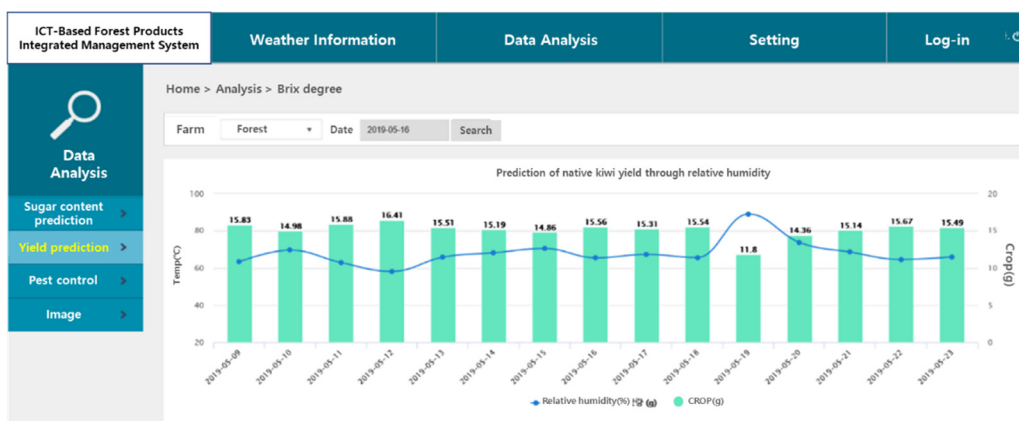

Figure 10. Result of predicting the production of Actinidia.

5. Conclusion

This paper proposed a field crop growth environment monitoring and big data analysis system. The proposed system consists of a self-generating environmental data collection node, an LPWA-based communication module, and a big data analysis server. We designed and developed a sensor node equipped with wind speed, wind direction, temperature, humidity, rainfall, and solar radiation sensors to collect the atmospheric environment, and ground temperature, humidity, and EC sensors to collect the soil environment. Considering the fact that there is no constant power supply, a LoRa-based LPWA sensing network using a self-generating system was established and installed at the field crop field, and data was transmitted to the server through a gateway. By combining a self-generating system and LPWA communication technology, it was shown to be a very efficient and economical solution for collecting and transmitting data in an outdoor environment. These solutions can be used in a variety of application fields, including sensor data collection in the open field, energy monitoring, and environmental monitoring.

Additionally, based on the oneM2M architecture, it is designed to process data from various sensors in a standardized way, allowing the system to be expanded more flexibly when new types of

sensors are added. The transmitted data is stored and managed on the server as big data, and can be used to predict the production and quality of field-grown crops and take appropriate measures. We implemented a system that predicts the yield and quality of forest products by analyzing big data stored on the server. Environmental information was collected from Actinidia cultivation areas and the results of predicting Actinidia yield and sugar content were presented. The proposed system is expected to contribute to improving the productivity of forest products and can be applied to the industrial field of monitoring the growth environment of other agricultural crops.

Author Contributions: Y.J.O is an expert in the field of artificial intelligence, augmented reality, metaverse and intelligent vehicle research, actively participating in various national projects in Korea. She contributes to algorithm development and conducts experiments using simulations. She has granted permission for the publication of the manuscript.

Institutional Review Board Statement: Not applicable.

Informed Consent Statement: Not applicable.

Data Availability Statement: Not applicable.

Conflicts of Interest: The authors declare no conflict of interest.

References

1. Choe, H.O.; Lee, M.-H. Artificial Intelligence-Based Fault Diagnosis and Prediction for Smart Farm Information and Communication Technology Equipment. *Agriculture* 2023, 13, 2124. <https://doi.org/10.3390/agriculture13112124>.
2. Joo, K.; Kim, H.M.; Hwang, J. Consequences of Psychological Benefits in the Context of Eco-Friendly Indoor Smart Farm Restaurants: The Moderating Role of Curiosity. *Sustainability* 2023, 15, 15496. <https://doi.org/10.3390/su152115496>
3. Sirimorok, N.; Paweroi, R.M.; Arsyad, A.A.; Köppen, M. Smart Farm Security by Combining IoT Sensor Network and Virtualized Mycelium Network. *Sensors* 2023, 23, 8689. <https://doi.org/10.3390/s23218689>
4. Dhillon, R.; Moncur, Q. Small-Scale Farming: A Review of Challenges and Potential Opportunities Offered by Technological Advancements. *Sustainability* 2023, 15, 15478. <https://doi.org/10.3390/su152115478>
5. Ojo, M.O.; Viola, I.; Baratta, M.; Giordano, S. Practical Experiences of a Smart Livestock Location Monitoring System Leveraging GNSS, LoRaWAN and Cloud Services. *Sensors* 2022, 22, 273. <https://doi.org/10.3390/s22010273>
6. Choi, W.; Chang, Y.-S.; Jung, Y.; Song, J. Low-Power LoRa Signal-Based Outdoor Positioning Using Fingerprint Algorithm. *ISPRS Int. J. Geo-Inf.* 2018, 7, 440. <https://doi.org/10.3390/ijgi7110440>
7. Ogudo, K.A.; Muwawa Jean Nestor, D.; Ibrahim Khalaf, O.; Daei Kasmaei, H. A Device Performance and Data Analytics Concept for Smartphones' IoT Services and Machine-Type Communication in Cellular Networks. *Symmetry* 2019, 11, 593. <https://doi.org/10.3390/sym11040593>
8. Choi, R.; Lee, S.; Lee, S. Reliability Improvement of LoRa with ARQ and Relay Node. *Symmetry* 2020, 12, 552. <https://doi.org/10.3390/sym12040552>
9. Wang, L.; Wang, C.; Lu, X.; Ping, D.; Jiang, S.; Wang, X.; Zhang, J. A Design for a Lithium-Ion Battery Pack Monitoring System Based on NB-IoT-ZigBee. *Electronics* 2023, 12, 3561. <https://doi.org/10.3390/electronics12173561>
10. Soy, H. Coverage Analysis of LoRa and NB-IoT Technologies on LPWAN-Based Agricultural Vehicle Tracking Application. *Sensors* 2023, 23, 8859. <https://doi.org/10.3390/s23218859>
11. Nguyen, H.; Le, N.T.; Hoan, N.C.; Jang, Y.M. Real-Time Mitigation of the Mobility Effect for IEEE 802.15.4g SUN MR-OFDM. *Appl. Sci.* 2019, 9, 3289. <https://doi.org/10.3390/app9163289>
12. Wang, L.; Wang, C.; Lu, X.; Ping, D.; Jiang, S.; Wang, X.; Zhang, J. A Design for a Lithium-Ion Battery Pack Monitoring System Based on NB-IoT-ZigBee. *Electronics* 2023, 12, 3561. <https://doi.org/10.3390/electronics12173561>
13. Semtech. LoRa and LoRaWAN: A Technical Overview. Online. 2019. Available online: https://loradevelopers.semtech.com/uploads/documents/files/LoRa_and_LoRaWAN-A_Tech_Overview-Downloadable.pdf (accessed on 8 November 2023).
14. Yang, X.; Karampatzakis, E.; Doerr, C.; Kuipers, F. Security Vulnerabilities in LoRaWAN. In Proceedings of the 2018 IEEE/ACM Third International Conference on Internet-of-Things Design and Implementation (IoTDI), Orlando, FL, USA, 17–20 April 2018; pp. 129 – 140.
15. Burczyk, R.; Czapiewska, A.; Gajewska, M.; Gajewski, S. LTE and NB-IoT Performance Estimation Based on Indicators Measured by the Radio Module. *Electronics* 2022, 11, 2892. <https://doi.org/10.3390/electronics11182892>

16. Fu, H.; Wang, X.; Zhang, X.; Saleem, A.; Zheng, G. Analysis of LTE-M Adjacent Channel Interference in Rail Transit. *Sensors* 2022, 22, 3876. <https://doi.org/10.3390/s22103876>
17. Benouakta, A.; Nguyen, T.M.; Ferrero, F.; Lizzi, L.; Staraj, R. Design of a Multi-Standard UWB-LoRa Antenna Structure and Transceiver Board for High-Accuracy and Long-Range Localization Applications. *Electronics* 2023, 12, 4487. <https://doi.org/10.3390/electronics12214487>
18. Al mojamed, M. LTM-LoRaWAN: A Multi-Hop Communication System for LoRaWAN. *Electronics* 2023, 12, 4225. <https://doi.org/10.3390/electronics12204225>
19. Ugwuanyi, S.; Paul, G.; Irvine, J. Survey of IoT for Developing Countries: Performance Analysis of LoRaWAN and Cellular NB-IoT Networks. *Electronics* 2021, 10, 2224. <https://doi.org/10.3390/electronics10182224>
20. oneM2M. <https://www.etsi.org/committee/1419-onem2m>
21. Taştan, M.; Gökozan, H. Real-Time Monitoring of Indoor Air Quality with Internet of Things-Based E-Nose. *Appl. Sci.* 2019, 9, 3435. <https://doi.org/10.3390/app9163435>
22. Yusoff, Y.M.; Rosli, R.; Karnaluddin, M.U.; Samad, M. Towards smart street lighting system in Malaysia. In Proceedings of the 2013 IEEE Symposium on Wireless Technology Applications (ISWTA), Kuching, Malaysia, 22–25 September 2013; pp. 301–305.
23. Kadusic, E.; Zivic, N.; Ruland, C.; Hadzajlic, N. A Smart Parking Solution by Integrating NB-IoT Radio Communication Technology into the Core IoT Platform. *Future Internet* 2022, 14, 219. <https://doi.org/10.3390/fi14080219>
24. Pappalardo, M.; Viridis, A.; Mingozzi, E. An Edge-Based LWM2M Proxy for Device Management to Efficiently Support QoS-Aware IoT Services. *IoT* 2022, 3, 169-190. <https://doi.org/10.3390/iot3010011>
25. <https://www.onem2m.org/technical/published-specifications/release-3>
26. <https://www.onem2m.org/technical/published-specifications/release-4>

Disclaimer/Publisher's Note: The statements, opinions and data contained in all publications are solely those of the individual author(s) and contributor(s) and not of MDPI and/or the editor(s). MDPI and/or the editor(s) disclaim responsibility for any injury to people or property resulting from any ideas, methods, instructions or products referred to in the content.