

Review

# Innate immunity in cardiovascular diseases – Identification of novel molecular players and targets

Wolfgang Poller<sup>1,2,3,\*</sup>, Bettina Heidecker<sup>1,3</sup>, Andrea Ammirati<sup>4</sup>, Andreas W. Kuss<sup>5</sup>, Ana Tzvetkova<sup>5,6</sup>, Wolfram C. Poller<sup>7</sup>, Carsten Skurk<sup>1,3</sup>, Arash Haghikia<sup>1,3,8</sup>

<sup>1,2</sup> Department of Cardiology, Campus *Benjamin Franklin*; and <sup>2</sup> Berlin-Brandenburg Center for Regenerative Therapies (BCRT), both at Charité - Universitätsmedizin Berlin, corporate member of Freie Universität Berlin, Humboldt-Universität zu Berlin, and Berlin Institute of Health, Berlin, Germany.

<sup>3</sup> German Center for Cardiovascular Research (DZHK), Site Berlin, Germany.

<sup>4</sup> De Gasperis Cardio Center and Transplant Center, Niguarda Hospital, Milano, Italy.

<sup>5,6</sup> Department of Functional Genomics, Interfaculty Institute of Genetics and Functional Genomics; and <sup>5</sup> Institute of Bioinformatics, both at University Medicine Greifswald, Greifswald, Germany.

<sup>7</sup> Cardiovascular Research Institute, Icahn School of Medicine at Mount Sinai, New York, NY, USA

<sup>8</sup> Berlin Institute of Health, Berlin, Germany.

\* Correspondence: pollerwolfgang1@gmail.com

**Abstract:** During the past few years unexpected developments have driven studies in the field of clinical immunology. One driver of immense impact was the outbreak of a pandemic caused by the novel virus SARS-CoV-2. Excellent recent reviews address diverse aspects of immunological research into cardiovascular diseases. Here, we specifically focus on selected studies taking advantage of advanced state-of-the-art molecular genetic methods ranging from genome-wide epi/transcriptome mapping and variant scanning to optogenetics and chemogenetics. First, we discuss emerging clinical relevance of advanced diagnostics for cardiovascular diseases including those associated with COVID-19 - with a focus on the role of inflammation in cardiomyopathies and arrhythmias. Second, we consider newly identified immunological interactions at organ and systems level which affect cardiovascular pathogenesis. Thus, studies into immune influences arising from the intestinal system are moving towards therapeutic exploitation. Further, powerful new research tools have enabled novel insight into brain – immune system interactions at unprecedented resolution. This latter line of investigation emphasizes the strength of influence of emotional stress - acting through defined brain regions - upon viral and cardiovascular disorders. Several challenges need to be overcome before the full impact of these far-reaching new findings will hit the clinical arena.

**Keywords:** Immunology; innate immunity; immunogenetics; noncoding genome; tRNA biology; evolutionary genetics

## 1. Introduction

Multiple excellent reviews have addressed diverse important aspects of immunological research into cardiovascular diseases during the past few years. In this review we specifically focus on preclinical and clinical studies which have provided unexpected insights by taking advantage of recent state-of-the-art molecular genetic and virological technologies ranging from clinical genome-wide transcriptome mapping and variant scanning to optogenetics and chemogenetics. Due to the intense worldwide efforts in these fields during the past years the present review cannot be comprehensive, but instead tries to convey an up-to-date perspective on promising developments which may shape research at the crossroads of cardiology – immunology - neurology (Fig. 1). Whereas advanced technologies are often confined to applications in basic research, we focus here on those with already proven or upcoming use in the clinical arena.

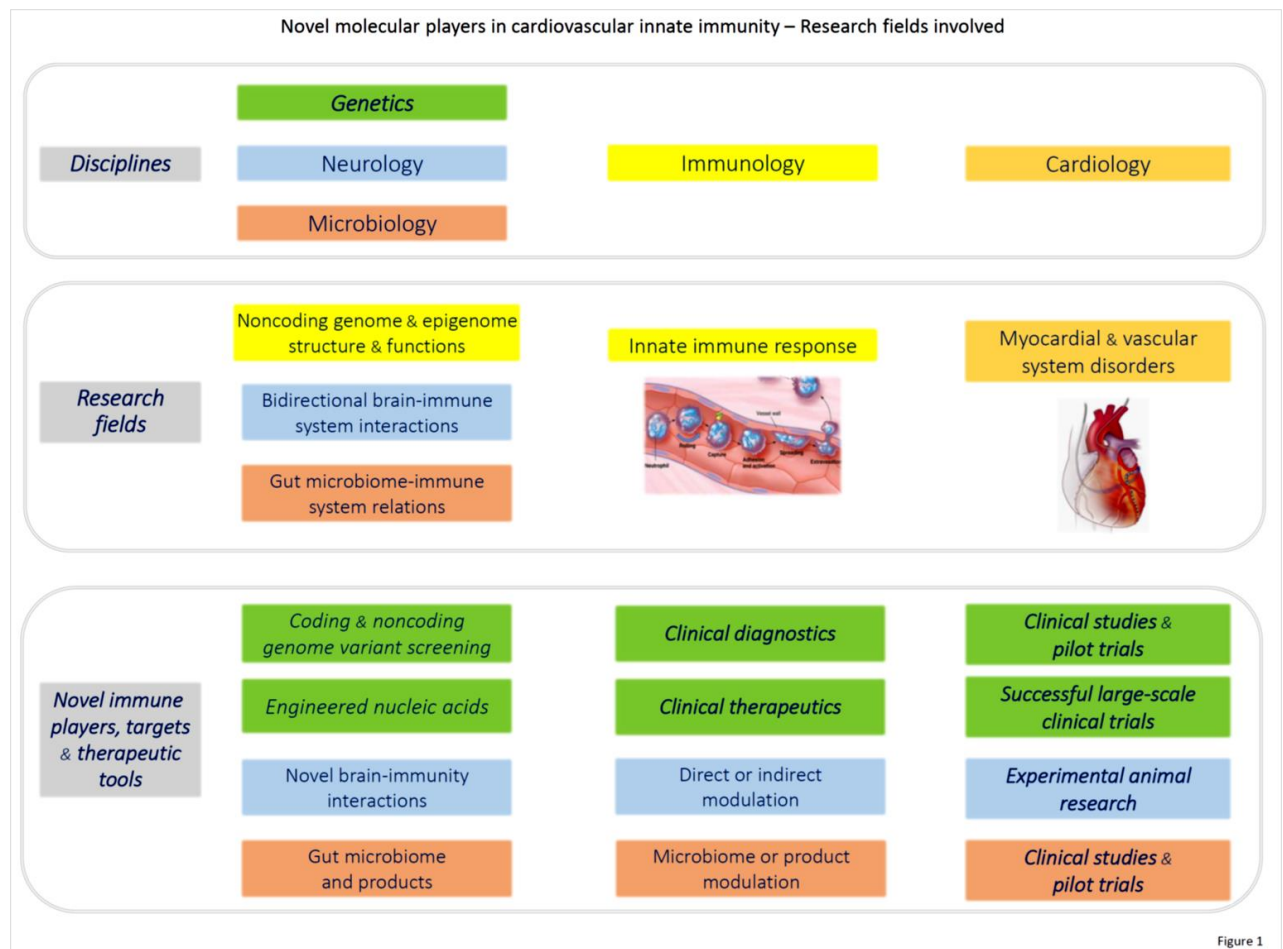

Figure 1. New research areas for cardiovascular diseases immunity

## 2. Molecular immunogenetics of cardiovascular diseases

While molecular genetic methods have been extensively employed in cardiovascular research since decades, only the rather recent advent of comprehensive and still affordable mutation/variant scanning tools ready for day-to-day clinical practice have significantly enhanced their clinical impact. As with all other topics discussed in this review, availability of practice-ready analytical tools is not simply a gradual step forward, but the critical threshold before widespread relevance for clinical medicine may be achieved. This degree of technological evolution may well take decades, as highlighted in recent reviews [1, 2] covering therapeutics based on noncoding RNAs and related nucleic acids. Once achieved, however, this defines the quantum leap from a “promising” to a “revolutionary” medical development.

### 2.1. Novel insights into the role of inflammation in human cardiomyopathies

Despite multiple obstacles to unequivocal detection of myocardial inflammation, it has been long known that myocardial inflammation [3-12] occurs in association with multiple types of ‘genetic’ [13-17] and ‘non-genetic’ [18, 19] cardiomyopathies. Fig. 2 provides an overview on currently known cellular receptors and signaling pathways linking innate immunity with cardiovascular diseases (CVD). For an excellent in-depth analysis of current knowledge in this field we refer the reader to Jaen et al. 2020 [20], and for an overview on CVD inflammation in general to a comprehensive review series [21].

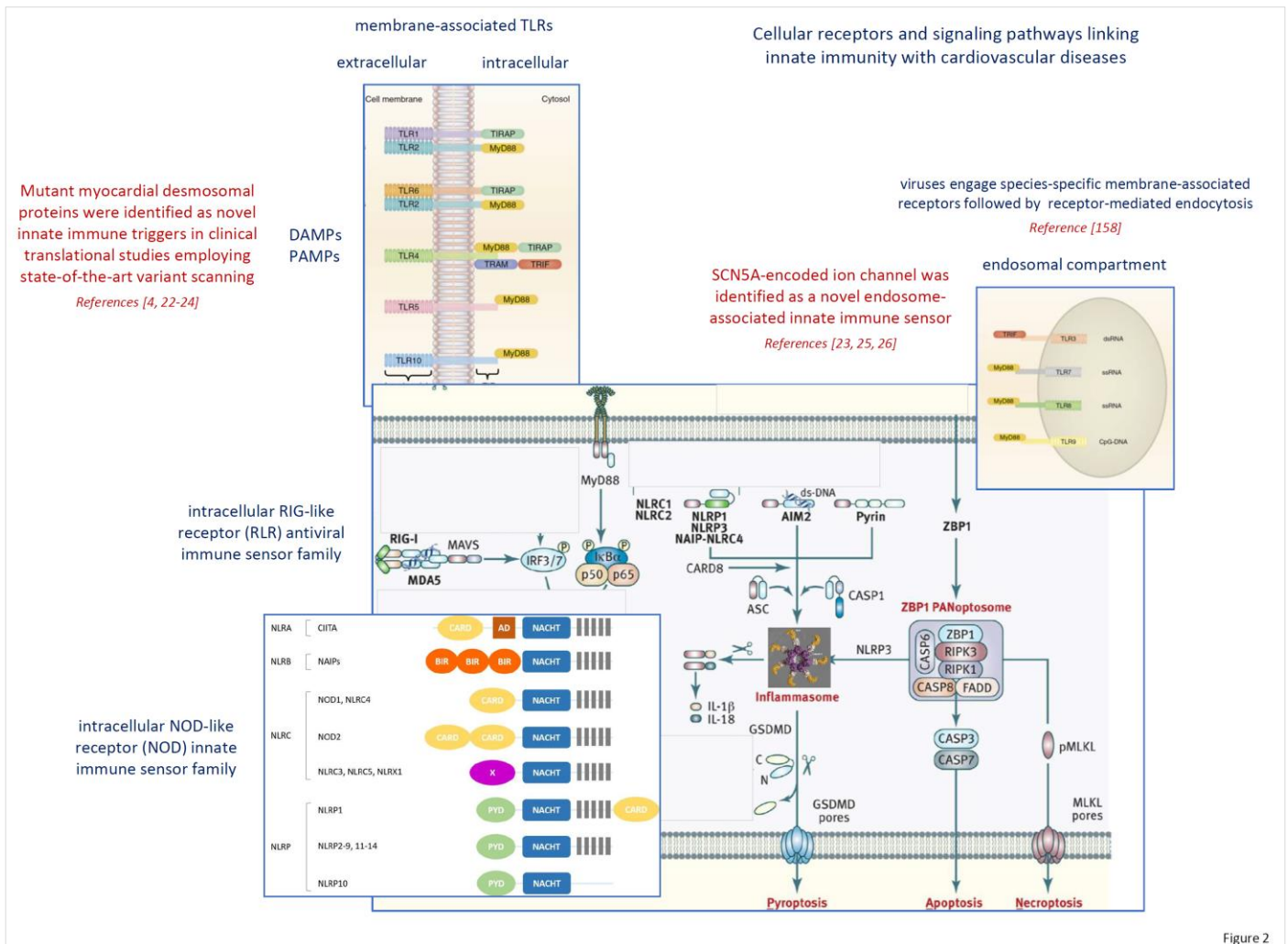

NEW Figure 2. Cellular receptors and signaling pathways linking innate immunity with cardiovascular diseases

Recent clinical studies employing highly advanced but clinical practice-ready genetic diagnostics [4, 22-24] have revealed significant direct impact of myocardial inflammation upon the induction of life-threatening arrhythmias. These studies investigated patients with well-defined genetic anomalies identified by large-scale mutation scanning. This research has so far led to the identification of a novel innate immune sensor (SCN5A sodium channel), and of hitherto unknown innate immune triggers (mutant desmosomal proteins) with significant implications for the clinical management of affected patients.

Thus, a missense variant E1295K of the sodium channel gene SCN5A was found to be associated with recurrent ventricular fibrillation and myocardial inflammation [23]. In this study, an immunosuppressive therapy course with prednisolone led to stabilization of cardiac rhythm and marked clinical improvement. SCN5A encodes sodium channel  $\alpha$ -subunit responsible for action potential initiation and conduction of electrical stimuli through the heart. SCN5A was initially assumed to be exclusively expressed in the myocardium, but recently a SCN5A splice variant was found to activate antiviral innate immune signaling [25]. Pioneering work revealed that SCN5A modulates myelin degradation by macrophages in multiple sclerosis (MS) and that overexpression of the macrophage SCN5A variant in mice protects against murine experimental MS [26]. Endosome-associated SCN5A variants thus emerged as novel innate immune sensors, indicating that patients so far classified as 'pure' myocardial ion-channel disease cases may carry independent 'immunologic' risk through hitherto-neglected anomalous function of their mutant ion channels. Another study taking advantage of high throughput mutation scanning found familial recurrent myocarditis to be triggered by exercise in patients with a

truncating variant of the desmoplakin gene [22]. This work illustrates the potential of advanced genetics in combination with state-of-the-art clinical myocardial diagnostics not only to improve clinical practice, but also to reveal unexpected pathogenetic processes. A third paper [4] investigating acute myocarditis associated with desmosomal gene variants (DGVs) found strong adverse impact of DGV-associated inflammation upon ventricular arrhythmogenesis and survival.

Unfortunately, there are multiple obstacles to unequivocal clinical recognition of myocardial inflammation as a precipitating factor for life-threatening arrhythmias or the development of terminal heart failure. Even in narrowly focused patient cohorts for whom genetic predisposition is suspected e.g. by family history or direct detection of pathogenic variants [4, 22, 23], recognition of myocardial inflammation requires in-depth diagnostic work-up (cardiac MRI, EMB, PET-CT) which may be unfeasible in many cases. Many of these patients may carry ICDs, often preventing reliable cardiac MRI diagnostics, and diagnostic accuracy of EMB may be limited by sampling error. Even *post mortem* examination would be unable to detect transient bouts of inflammation during the sometimes decades-long course of cardiomyopathies, unless inflammation persists until the time of death.

It is most likely that only a minute fraction of all inflammation-triggered arrhythmic events or critical heart failure progression is currently detected in routine clinical practice, generating a blind spot regarding the potential value of anti-inflammatory treatments in these contexts. The above studies employing state-of-the-art genetic tools strongly suggest to further evaluate the hypothesis of independent immunologic risk in major cohorts of patients carrying SCN5A or desmosomal gene variants. Conduction of such studies is challenging indeed and requires multicentric cooperation between experienced centers, but given the often young age of affected patients and possible life-saving impact the effort appears warranted. For an in-depth discussion regarding design and key problems of immunomodulating treatment trials in human cardiomyopathies we may refer the reader to a comprehensive recent review [27].

## 2.2. Common gene variants affecting antiviral response and myocardial disease

To illustrate that not only rare genetics variants, but also rather common genetic polymorphisms may significantly influence the immune response and associated cardiovascular diseases, we briefly discuss here a number of studies into the forkhead transcription factor Foxo3 [28, 29]. Foxo3 is involved in cell cycle regulation, apoptosis, oxidative stress, angiogenesis, and immunity. The immune-modulatory function of Foxo3 in adaptive immune responses has been elucidated to some extent. Foxo3 contributes to maintenance of T cell tolerance and quiescence and the differentiation of regulatory T cells is regulated by the transcription factor [30-32]. Moreover, Foxo3 maintains neutrophil vitality in models of neutrophil inflammation [33], plays an important role in cardiac hypertrophy [34], cardiomyocyte survival [35], cell differentiation and remodelling [36], and provokes resistance to oxidative stress in cardiac fibroblasts [37].

Remarkably, single nucleotide polymorphisms (SNPs) of the *FOXO3* gene are associated with longevity [38, 39], and low prevalence of cardiovascular diseases in diverse populations. These impressive initial studies have triggered a broad spectrum of research into translational aspects of Foxo3. Regarding the immune response, a human SNP in *FOXO3* is associated with increased risk for malaria, but a milder course in patients with autoimmune disease [40]. Further, combined experimental and clinical work revealed that Foxo3 negatively regulates natural killer (NK) cell function and viral clearance in myocarditis [41]. Virus-triggered myocarditis is associated with high mortality and an important cause for the need for heart transplantation. It is not well understood how the immune system recognizes and controls coxsackievirus B3 (CVB3) infections [42, 43], but murine studies suggest that NK cells play a critical role in viral clearance and host survival. Consistent with this, a paper by Loebel et al. [41] found an association of the *FOXO3* SNP rs12212067 with human NK cell function and clinical outcome in patients with virus-positive inflammatory cardiomyopathy, corroborating evidence from animal studies.

### 2.3. Novel immune players from the human non-coding genome

Similar to the above considered evolution of molecular genetic diagnostics, decades passed from the discovery that about 99% of the human genome do not encode proteins, but instead generate a broad spectrum of non-coding RNAs (ncRNAs) many of whom are involved in the immune response [44-60], until finally successful clinical exploitation of ncRNAs and of novel drugs developed using them as blueprints was achieved [1, 2]. Across the entire spectrum of medical disciplines it has been ascertained that the non-coding genome plays a key role in genetic programming and gene regulation during development as well as in health and disease. Fig 3 displays the general structure and some key features of the human noncoding genome and epigenome as well as suggested novel therapeutic targets therein.

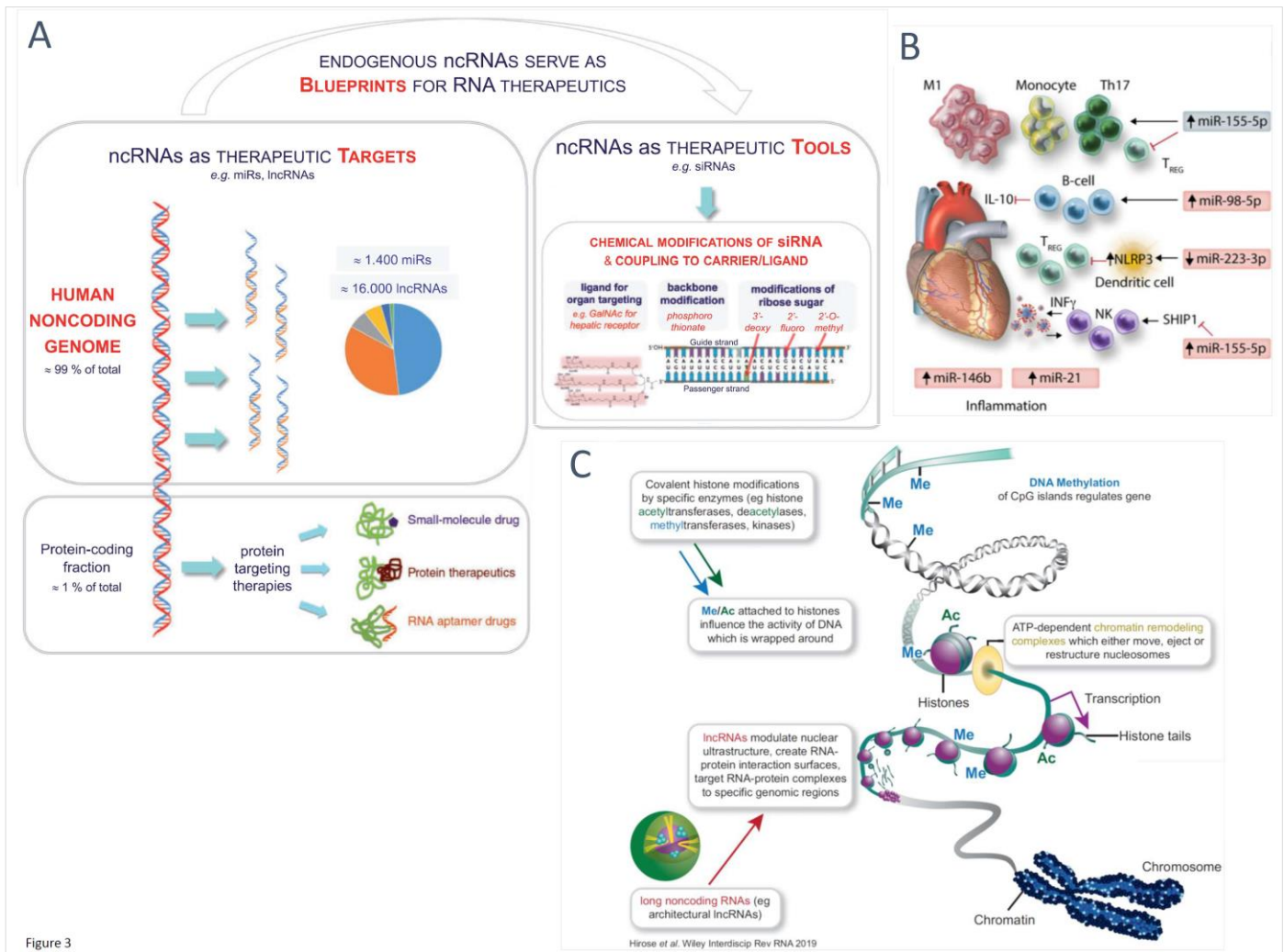

NEW Figure 3. Key features of the human noncoding genome and epigenome and novel therapeutic targets therein

In order to provide a fully balanced state-of-the-art assessment of the technically highly demanding field and rapidly evolving field of human genome research, we briefly address some current fundamental knowledge gaps regarding the molecular workings of diverse ncRNA species within intact fully functional cells. While the biosynthetic pathways and interactions of many miRNAs and RNAi-inducing siRNAs have been extensively characterized, this is not the case for the highly diverse species summarized under the rather unspecific term 'long-noncoding'. This huge pool encompassing many thousands of transcripts is in fact essentially unexplored with regard to mechanisms as well as biological relevance in health and disease. Different lncRNAs may modulate nuclear ultrastructure (e.g. *MALAT1*, *NEAT1*), create RNA-protein interaction surfaces, or target RNA-

protein complexes to specific genomic regions, making obvious that a more straightforward classification is needed in the future. While reductionist analysis in cell-free or other simple systems may reveal molecular insights, this does not yet reveal biological function in an intact differentiated cell or *in vivo*. Recent critical reviews [61, 62] have pointed out that essentially each lncRNA needs to be analyzed *per se* because of their diversity, and therefore suggest to focus research upon species fulfilling diverse criteria of biological relevance in humans.

#### 2.4. Novel nucleic acid therapeutics targeting conventional protein-coding genes and noncoding RNA targets

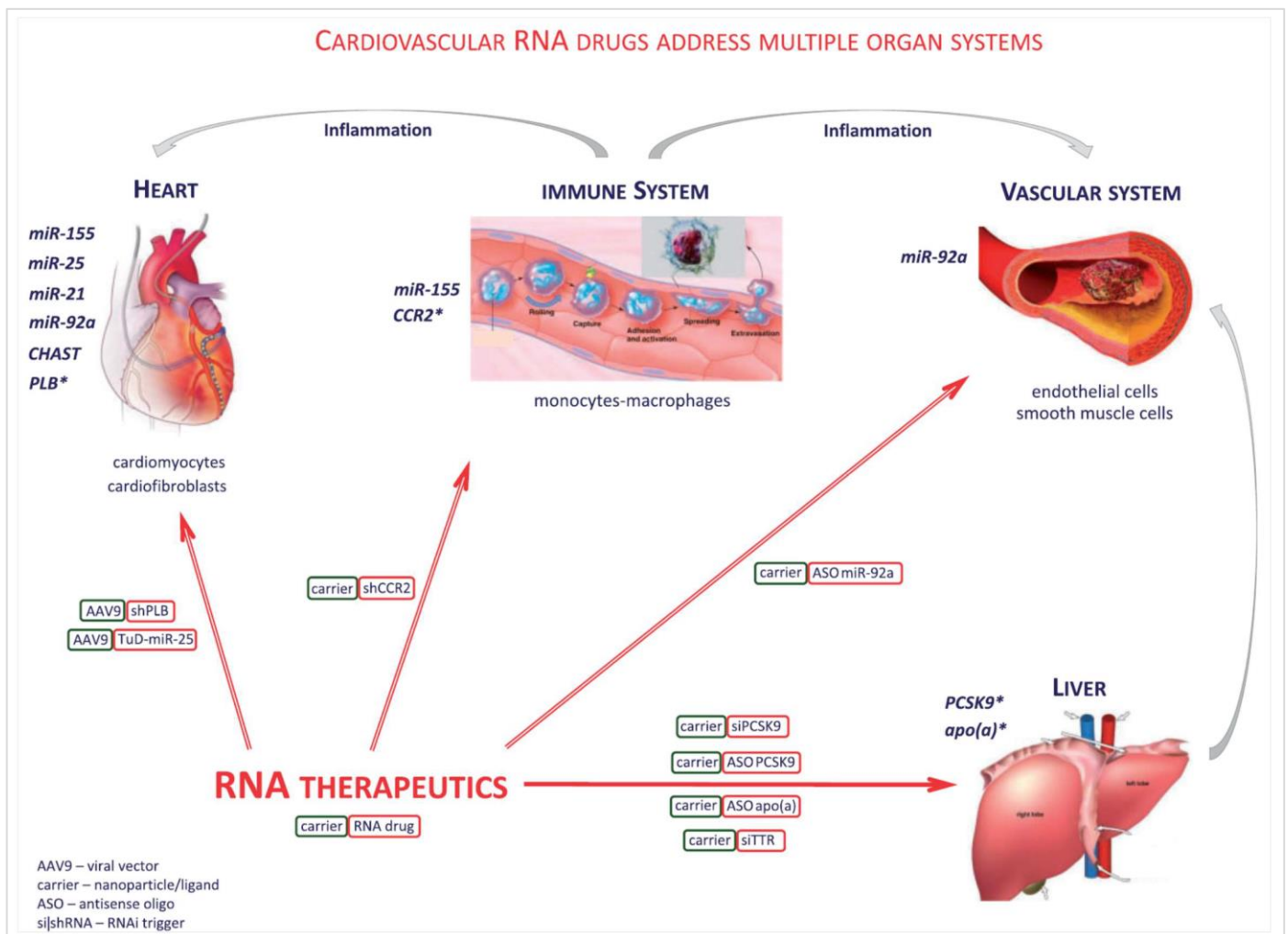

NEW Figure 4. Novel nucleic acid therapeutics targeting conventional protein-coding genes or noncoding RNA targets

Within the cardiovascular field, multiple early experimental studies [63-72] showed that certain ncRNAs (miRNAs) are regulators of cardiovascular pathogenesis in animal models. This of course immediately suggested they might have potential to improve diagnostics and could possibly even be developed into novel therapeutics. The road to in-depth understanding of the molecular workings of at least a few of the numerous ncRNA classes, and the development of sophisticated bioengineered nucleic acid drugs [63, 73-83] safe and efficacious for clinical applications, took two decades counting from early experimental work to the first clinically successful trials. Fig. 4 provides an overview on novel nucleic acid therapeutics targeting conventional protein-coding genes or noncoding RNA targets with relevance in cardiovascular disorders. Particularly advanced is the development of RNA interference (RNAi) drugs which use recently discovered pathways of

endogenous short interfering RNAs and are becoming versatile tools for efficient silencing of protein expression. Pioneering clinical studies include RNAi drugs targeting liver synthesis of PCSK9 resulting in highly significant lowering of LDL cholesterol or targeting liver transthyretin (TTR) synthesis for treatment of cardiac TTR amyloidosis. Further novel drugs mimicking actions of endogenous ncRNAs may arise from exploitation of molecular interactions not accessible to conventional pharmacology. For a more in-depth coverage of the enormously challenging bioengineering, safety and regulatory hurdles to be overcome towards clinical therapy during the past decades we may refer the reader to comprehensive recent reviews [1, 2, 84].

Whereas a series of ground-breaking clinical trials [77, 81, 82, 85-105, 106 ] has provided definite evidence of therapeutic potential of RNA interference and antisense drugs for cardiovascular disorders, the inclusion of ncRNA profiling into the clinical diagnostic process and prognosis assessment is less conclusive so far. Still, it may significantly contribute to optimize patient care in selected complex or otherwise equivocal cases. Thus, rapid diagnosis of life-threatening idiopathic giant cell myocarditis and cardiac sarcoidosis is significantly improved by myocardial gene expression profiling [107]. In another disease with highly variable clinical course and outcome, human enterovirus cardiomyopathy, differential cardiac microRNA profiling helps to predict the clinical course and the need for antiviral therapy [108]. As another example, circulating exosomal microRNAs predict functional recovery after interventional repair of severe mitral regurgitation [109]. Of course it needs to be emphasized that the definitive establishment of predictive or differential diagnostic expression profiles requires confirmation by several independent clinical studies. This has been rarely achieved so far [1, 2], but the available evidence does suggest significant clinical potential for selected clinical settings [1, 2, 110-113].

### 2.5. Continuously emerging new levels of complexity of the human genome

The more recent history of human genetics is characterized by several revolutionary discoveries [1, 2]. After the very important sequencing of the entire genome of humans (and meanwhile of a vast number of other species) it became apparent that 99% of the ascertained sequence does not encode proteins. This already suggested that this huge noncoding fraction plays truly critical and so far only very incompletely understood roles for the proper functioning and environmental adaptations of individuals, but for evolution itself through advanced species. Furthermore, prenatal influences as well as environmental factors are known to alter the genome through epigenetic mechanisms or imprinting. An individual's genome is on the one hand rather fixed at DNA level (except somatic mutations/recombinations), but it's functional status may still be significantly and durably altered by the environment via epigenetics. One may safely assume these complexities of evolutionary advanced genomes convey a distinct survival benefit, otherwise they would not have become commonplace in higher species. In the following we consider further data suggesting that certain genomic regions give rise to multiple immunomodulatory transcripts interacting with each other in a way reminiscent of integrated electronic circuits to generate an optimized responses to complex inputs. All hitherto known functional levels of the genome – from DNA editing [81, 98, 99] to epigenome-targeting “epi-drugs” [100, 114-120] – have already been investigated with regard to possible therapeutic potential.

To illustrate the multi-level functional integration of major strands of the human genome, we invoke the evolutionary conserved *NEAT1-MALAT1* cluster encountering high interest in both cardiovascular medicine and oncology. In the cardiovascular field, suppression of lncRNA *NEAT1* was observed in circulating immune cells of post-myocardial infarction (MI) patients. Mice lacking the lncRNAs *NEAT1* or *MALAT1* displayed immune disturbances affecting monocyte-macrophage as well as T cell differentiation and rendering the immune system highly vulnerable to stress stimuli, thereby promoting the development of atherosclerosis. Uncontrolled inflammation is also a key driver of multiple other diseases. The human *NEAT1-MALAT1* gene cluster generates large noncoding transcripts remaining nuclear, while tRNA-like transcripts (mascRNA, menRNA),

enzymatically generated from these precursors, translocate to the cytosol. *NEAT1<sup>-/-</sup>* and *MALAT1<sup>-/-</sup>* mice display massive atherosclerosis and vascular inflammation [121-124]. A recent study found that these tRNA-like molecules are critical components of innate immunity. They appear as prototypes of a new class of noncoding RNAs distinct from others (miRNAs, siRNAs) by biosynthetic pathway and intracellular kinetics. CRISPR-generated human  $\Delta$ mascrRNA and  $\Delta$ menRNA monocytes/macrophages display defective innate immune sensing, loss of cytokine control, imbalance of growth/angiogenic factor expression impacting upon angiogenesis, and altered cell-cell interaction systems. Antiviral response, foam cell formation/oxLDL uptake, and M1/M2 polarization are defective in  $\Delta$ mascrRNA and  $\Delta$ menRNA macrophages, defining the tRNA-like molecules' first described biological functions [125]. This study revealed that menRNA and mascrRNA represent novel components of innate immunity arising from the noncoding genome. Their *NEAT1-MALAT1* region of origin appears as archetype of a functionally highly integrated RNA processing system [125].

Two other recent studies illustrate the power of state-of-the-art genetics to reveal fundamentally new insights into immune system evolution [126] and large-scale human evolution in general [127]. Thus, a protective HLA extended haplotype was found to outweigh the major COVID-19 risk factor inherited from Neanderthals in the Sardinian population [126]. Another large study [128] conducted multilocus genotyping of SARS-CoV-2 genomes sampled globally and found evidence the majority of SARS-CoV-2 infections in 2020 and 2021 caused by genetically distinct variants that likely adapted to local populations. For further information on novel insights into genome structure and function we may refer the reader to a series of recent landmark papers and websites [62, 129-144].

Beyond the developments as reviewed in section 2.3, a further level of complexity—*i.e.* the human epigenome and its life-time dynamics in health and cardiovascular disease [84, 145-154] – emerged as holding promise for possible therapeutic exploitation [114-120, 155, 156]. At the present time, however, the impact of epigenetic drugs upon clinical medicine is still limited as compared to the nucleic acid drugs discussed above.

### 3. Current expansion of virological research in the cardiovascular field

#### 3.1. Impact of viral infections upon the cardiovascular system

Infection of the myocardium with cardiotropic viruses is one of the main causes of myocarditis and acute and chronic inflammatory cardiomyopathy (DCMi). However, viral myocarditis and subsequent dilated cardiomyopathy is still a challenging disease to diagnose and to treat and is therefore a significant public health issue globally [157]. Advances in clinical phenotyping and thorough molecular genetic analysis of intramyocardial viruses and their activation status have incrementally improved our understanding of molecular pathogenesis and pathophysiology of viral infections of the heart muscle. To date, several cardiotropic viruses have been implicated as causes of myocarditis and DCMi. These include, among others, classical cardiotropic enteroviruses (Coxsackieviruses B) [42, 158], the most commonly detected parvovirus B19 [159], human herpes virus 6 [160, 161], and hepatitis C virus (HCV) [162, 163]. Entirely unwelcome newcomer is the respiratory virus which has triggered the worst pandemic since a century, SARS-CoV-2, whose involvement and impact in viral cardiovascular disease is under scrutiny [164-169]. Despite extensive research into the pathomechanisms of viral infections of the cardiovascular system (Fig. 5), our knowledge regarding their treatment and management is still incomplete. Recent reviews aimed to explore and summarize the current knowledge and available evidence on viral infections of the heart, focused on

pathophysiology, diagnostics, clinical relevance and cardiovascular consequences, and current and novel treatment strategies [157].

NEW Figure 5. Cellular receptor-mediated entry and innate immune activation mechanisms of human-pathogenic viruses

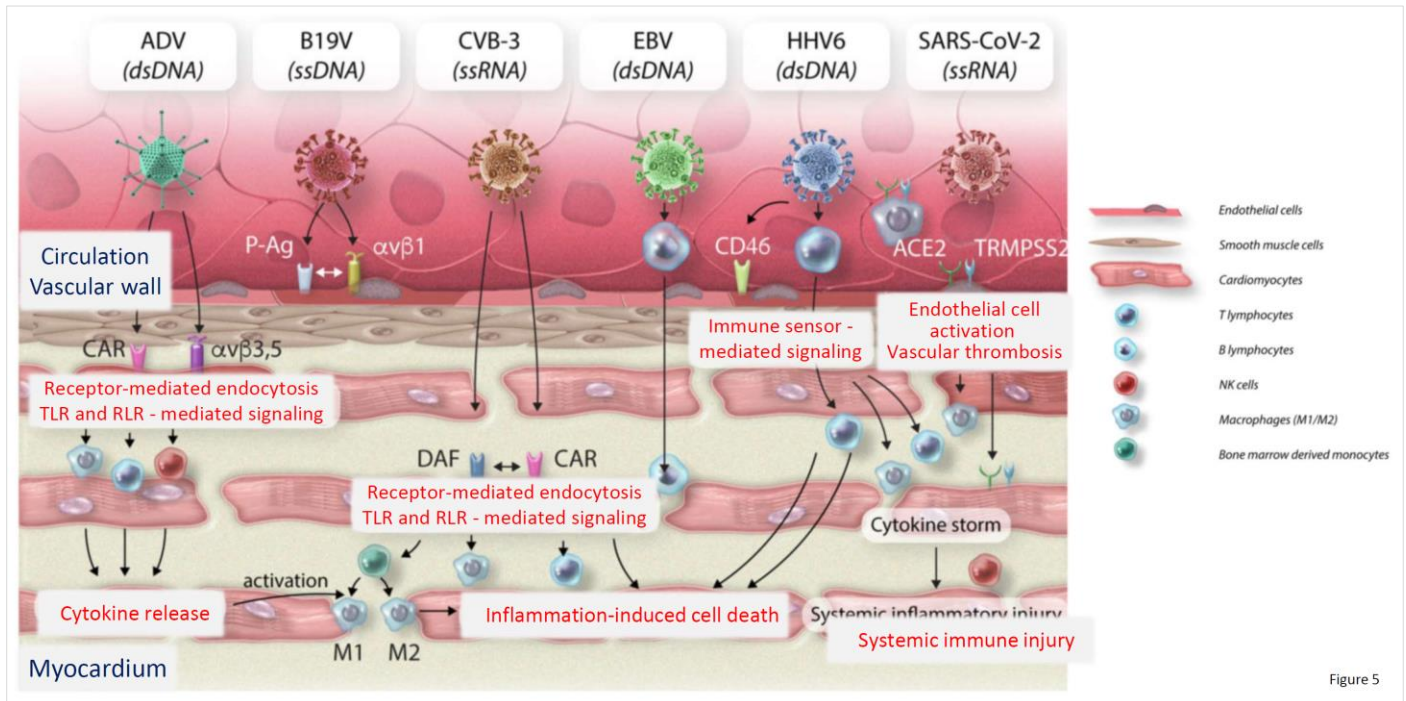

Figure 5

*Prophylaxis and vaccination:* Whereas conventional antiviral vaccine development methods have proven efficient against SARS-CoV-2, the most recent virus inducing the COVID 19 pandemic, novel RNA-based vaccines have yielded exceptionally good results against this pathogen. The revolutionary method successfully used to develop the BioNTecVC and ModernaVC vaccine was never before employed at scale, and indeed the RNA modification/stabilization/purification methods as well as the associated nanoparticle delivery tools are of recent origin. Importantly, as emphasized by the authors of the landmark paper reporting the results of the BioNTecVC vaccine trial, development of the vaccination RNA sequence started immediately after publication of the novel virus genome sequence, which was derived soon after the recognition of COVID-19 as a new disease entity. Speed of development and adaptability to entirely new or variant viruses, which unfortunately are most likely to emerge in the future, bring significant advantages lasting beyond the current pandemic.

*Need for highly versatile antiviral tools:* The current pandemic, originating from transmission of a mutated animal virus to men, has heightened concerns and awareness that amongst the vast number of animal viruses others may cross the species barrier to humans. Therefore, foresighted expansion of our antiviral arsenal appears warranted. Fortunately, novel therapeutic approaches as reviewed in section 2.3 offer high versatility enabling rapid adaption to essentially any coding or non-coding, viral or host cell, molecular target [170-178]. Further, their large-scale production will follow similar (*i.e.* RNA, DNA, and XNA) synthetic pathways, enabling massive up-scaling of therapeutics production if required.

*Advanced molecular virological tools:* While several human-pathogenic cardiotropic viruses are identified, there is good reason to believe that traditional molecular virological tools (*e.g.* PCR, RT-PCR) will fail to recognize novel viruses with any of those currently in focus. Thus, the etiology of giant cell myocarditis (GCM), most fulminant and life-threatening of the inflammatory cardiomyopathies, is unknown. GCM presents with extensive myocardial inflammation that is only responding to high-dose immunosuppression. GCM has been associated with other autoimmune diseases, suggesting a relevant

autoimmune component in its pathogenesis. However, the phenomenon of giant cells has been observed during viral infections such as herpes, suggesting a contribution of viral pathogens. In a recent paper, a study of plasma, peripheral blood mononuclear cells, endomyocardial biopsies (EMBs), and cardiac tissue samples from explanted heart of patients with GCM and other subtypes of myocarditis [179], *Virome Capture Sequencing for Vertebrate Viruses (VirCapSeq-VERT)* was employed, a novel method that simultaneously screens for all known vertebrate viruses with sensitivity similar to real-time PCR [179, 180]. The entire field of basic and clinical virology took great advantage from broad application of novel technologies and large – sometimes global— research consortia [181-183]. Within the cardiovascular field, extended use of these novel, more comprehensive virological tools may well lead to important insights into the pathogenesis of long-known but still etiologically enigmatic human diseases (cardiac sarcoidosis, eosinophilic cardiomyopathy, GCM and others.)

### 3.2. *The human genetic architecture of SARS-CoV-2*

The current COVID-19 pandemic, caused by infection with SARS-CoV-2, resulted in enormous health and economic burden worldwide [184-187]. One of the most remarkable features of SARS-CoV-2 infections is the extremely high variability of clinical sequelae, ranging from asymptomatic patients to life-threatening pneumonia and acute respiratory distress syndrome [157, 164-167, 188-195]. Since the rise of the COVID-19 pandemic, there has been an urgent need to identify pathophysiological characteristics leading to a severe clinical course in patients infected with SARS-CoV-2 [157].

Although established host factors correlate with disease severity (*e.g.* increasing age, male sex, higher body-mass index), these risk factors alone do not explain all of the variability in disease severity observed across individuals. Genetic factors contributing to COVID-19 susceptibility and severity may provide new biological insights into disease pathogenesis and identify mechanistic targets for therapeutic development or drug repurposing, as treating the disease remains a highly important goal despite the recent development of vaccines. A large number of genome-wide association studies (GWAS) addressing the contribution of common genetic variation to COVID-19 in different populations worldwide have provided support for the involvement of several genomic loci associated with COVID-19 severity and susceptibility [128, 178, 188-191, 196-202]. The global COVID-19 Host Genetics Initiative (COVID-19 HGI) (<https://www.covid19hg.org/>) [203] recently reported the results of meta-analyses of 46 studies from 19 countries for host genetic effects [191]. Smaller studies analyzed *e.g.* the association between COVID-19 severity and HLAs in 435 individuals from Germany ( $n = 135$ ), Spain ( $n = 133$ ), Switzerland ( $n = 20$ ) and the United States ( $n = 147$ ). This study described a biologically plausible potential association of HLA-C\*04:01 with severe clinical course of COVID-19, as HLA-C\*04:01 has fewer predicted binding sites for relevant SARS-CoV-2 peptides compared to other HLA alleles.

For an excellent overview and discussion of invoked loci and their clinical implications we refer the reader to van der Made *et al.* [196] who provide comprehensive tables with significant large-scale genome-wide associations in patients with severe or critical COVID-19. Importantly, they also review and discuss the reported outcomes of SARS-CoV-2 infection in patients with known inborn errors of immunity (IEI). One recent study [197] important for the assessment of GWAS emphasizes the impact of COVID-19 phenotype definitions, and revealed distinct patterns of genetic association and protective effects upon their replication analysis of 12 previously reported COVID-19 genetic associations. From a clinical practice perspective, GWAS have not identified a single gene locus with overwhelming impact upon disease course suggesting population-wide screening for high-risk individuals. On the other hand, for severely affected patients genetic screening for IEI as suggested by van der Made *et al.* [196] may reveal individual clinical insights with possible therapeutic use.

Another type of contribution of large-scale molecular genetic analyses to better understand the variable clinical expression of SARS-CoV-2 infections, and the global

dynamics of virus evolution, has been published by Chan *et al.* [128]. They have described the contrasting epidemiology and population genetics of COVID-19 infections defined by multilocus genotyping of the SARS-CoV-2 genomes. Their analysis of 22,164 SARS-CoV-2 genomes sampled worldwide suggests that the majority of SARS-CoV-2 infections in 2020 and 2021 were caused by genetically distinct variants that likely adapted to local populations.

### 3.3. Cardiovascular immunobiology of COVID-19 and long COVID syndromes

With regard to cardiovascular medicine, it is desirable to know specific genetic risk factors for the development of myocarditis during COVID-19 or upon vaccination [112, 164-169, 204-209], or for development of long COVID syndromes [190, 210-213].

Fortunately, SARS-CoV-2 is rather rarely directly causing severe myocarditis or cardiomyopathies [164-169]. While SARS-CoV-2 may infect human engineered heart tissues and models of COVID-19 myocarditis [168], the observed effects in COVID-19 patients are rather induced by secondary immune phenomena than by the virus itself [165]. Since there is continuous molecular evolution of the SARS-CoV-2 virus, however, it is important to note that human endothelial cells have shown increased susceptibility to infections by SARS-CoV-2 variants [193]. In COVID-19 patients developing any myocardial involvement, the molecular virological and immunological tools outlined in section 3.1 should be employed to characterize the myocardial disease, since this may enable individualized measures beyond standard heart failure and antiarrhythmic therapy.

## 4. Novel immune pathomechanisms at organ and systemic level

The individual response of the innate immune system to environmental (e.g. viral or other microbial infections) as well as to endogenous stimuli (e.g. tissue injury of any kind) is partially determined by genetic factors, but subject to modulation by non-genetic factors (e.g. stress of various types). While this has been well known for decades [214-216], recent research employing novel research tools [217-226, 248] has uncovered interactions between brain and immune system at unprecedented resolution. Similarly, advanced molecular genetic methods [181, 227-232] contributed to elucidate mechanistic pathways linking the GIT microbiome to the systemic innate immune response with its impact upon cardiovascular [233, 234] and neurological diseases [235, 236]. Below we try to assess the clinical translational status of these research fields, focusing on therapeutic modulation of stress-induced disturbed brain - immune system interactions (section 4.1), and of the GIT microbiome and its products (section 4.2).

### 4.1. Brain - immune system interactions

The adverse effect of psychological stress upon various human diseases has been well known since decades [214-216] and several stress-induced brain - immune system interactions have been elucidated at cellular and molecular level [215, 237]. It is also obvious that stress reduction is highly desirable with regard to cardiovascular diseases [238-241], although often difficult to achieve in everyday life or the clinical setting. Any new avenue arising from recent neuroimmune research would be most welcome, of course. Clinically, neuromodulation strategies have been evaluated to reduce inflammation and lung complications of COVID-19 patients [242], and cardiovascular sequelae in posttraumatic stress disorders [243]. In experimental animal models other approaches have been addressed: brain control of humoral immune responses by behavioural modulation [244]; modulation of the gut microbiome regulating psychological stress-induced inflammation [245, 246]; IL-17A blockade or depletion of Th17 cell-inducing gut microbiota to reduce stress-induced vaso-occlusive episodes (VOEs) of sickle cell disease as a vascular disease model [245].

Folk wisdom has long suggested that emotional stress takes a toll on health. The field of psychoneuroimmunology is now providing novel mechanistic insight into the

pathways through which psychological stress and negative emotions are translated into physiological changes [216]. Neuroimmunology in general is one of the fastest-growing fields in the life sciences aiming to stepwise elucidate the highly complex interactions between nervous system and immune system at the molecular and cellular level [247-251]. It is long known that acute and short-term stress induce rapid and significant redistributions of immune cells among different body regions. The underlying mechanisms are under close scrutiny, as stress-induced leukocyte redistribution appears to be of fundamental importance for survival. It appears critical to direct suitable immune cells to defined target organs in response to diverse external or internal challenges, thus significantly enhancing speed and efficacy of the immune response [247-250] [251].

Despite this secured general knowledge, the details of the mechanistic pathways linking stress networks in the brain to peripheral leukocytes remain poorly understood. A recent experimental study has, for the first time, demonstrated that distinct brain regions shape leukocyte distribution and function throughout the body upon different types of acute stress in mice. Employing optogenetics and chemogenetics this work revealed that motor circuits induce rapid neutrophil mobilization from the bone marrow to peripheral tissues via skeletal-muscle-derived neutrophil-attracting chemokines. Conversely, the paraventricular hypothalamus controlled monocyte and lymphocyte egress from secondary lymphoid organs and blood to the bone marrow through direct, cell-intrinsic glucocorticoid signaling. These stress-induced, counter-directional, population-wide leukocyte shifts were associated with altered disease susceptibility. On the one hand, acute stress changed innate immunity by reprogramming neutrophils and directing their recruitment to sites of injury. On the other hand, corticotropin-releasing hormone neuron-mediated immune cell shifts protected against the acquisition of autoimmunity, but impaired immunity against SARS-CoV-2 and influenza infection. These data identified distinct brain regions differentially and rapidly tailoring the immune cell landscape during psychological stress, thereby calibrating the ability of the immune system to respond to physical threats [248].

A recent study in mice and humans [251] revealed that sleep exerts lasting effects on hematopoietic stem cell function and diversity. In mice, sleep fragmentation altered the hematopoietic stem and progenitor cells (HSPCs) epigenome, priming cells for exaggerated inflammatory bursts. In humans, sleep restriction altered the HSPC epigenome and activated hematopoiesis. This work provides, for the first time, mechanistic insight into the prolonged effects of sleep disruption, another well-known stress-factor.

A third neuro-immune study investigated whether brain activities may directly control adaptive immune responses in lymphoid organs [244]. It was found that splenic denervation in mice specifically compromised plasma cell formation during a T cell-dependent, but not T cell-independent, immune response. Neurons in the central nucleus of the amygdala (CeA) and the paraventricular nucleus (PVN) expressing corticotropin-releasing hormone (CRH) connected to the splenic nerve. Ablation or pharmacogenetic inhibition of these neurons reduced plasma cell formation, while pharmacogenetic activation of these neurons increased plasma cell abundance. A behaviour regimen, with mice made to stand on an elevated platform, led to activation of CeA and PVN CRH neurons and increased plasma cell formation. In immunized mice, the elevated platform regimen induces an increase in antigen-specific IgG antibodies. By identifying a specific brain-spleen neural connection autonomically enhancing humoral responses, and by demonstrating immune stimulation by behaviour modification, this experimental study revealed brain control of adaptive immunity, suggesting possible enhancement of immunocompetency by behavioural intervention.

Another study, employing retrograde tracing and chemical as well as surgical and chemogenetic manipulations, identified a sympathetic aorticorenal circuit that modulates ILC2s in gonadal fat and connects to higher-order brain areas, including the paraventricular nucleus of the hypothalamus [278]. Similar to the other work, these results identify a neuro-mesenchymal unit translating signals from long-range neuronal circuitry into adipose-resident ILC2 function, thereby modulating host metabolism and obesity.

#### 4.2. Immune impact and therapeutic perspectives of the intestinal microbiome

The gastrointestinal tract (GIT) hosts a pool of immune cells representing 70% of the entire immune system, and the largest population of macrophages in the human body [244]. Through its local immune system, the GIT detects and responds to the local microbiome [236], but also impacts upon remote immune processes [252-267]. During the past years multiple experimental studies have revealed that the microbiome and local immune system of the GIT may modulate distant inflammation within the cardiovascular system and brain [216, 218, 235, 236, 245, 247, 268-276]. However, whereas experimental models incriminate disturbed gut microbiota in a number of diseases (CNS disorders, atherosclerosis), data from human studies are sparse [270, 271, 277, 278]. A theoretical basis for the use of microbiota-directed therapies in these disorders has been developed, but support from stringent clinical trials is missing and clinical confirmation is not yet received.

Regarding the cardiovascular system, a recent combined experimental and clinical study identified a novel regulatory circuit that links the gut microbiota metabolite propionic acid (PA), a short-chain fatty acid, with the gut immune system to control intestinal cholesterol homeostasis. The mechanism involves PA-mediated increase in regulatory T-cell numbers and IL-10 levels in the intestinal microenvironment, subsequently suppressing the expression of NPC1L1, a major intestinal cholesterol transporter. In a proof-of-concept clinical study, it was demonstrated that oral supplementation of PA over the course of 8 weeks significantly reduced LDL and non-HDL cholesterol levels in hypercholesterolaemic subjects. The data suggest PA supplementation may improve cholesterol homeostasis and contribute to cardiovascular health. Another translational perspective is modulation of the gut microbiome by dietary approaches, or by prebiotics to sustainably increase the intestinal abundance of PA producing species as an "intrinsic" concept of atheroprotection [233, 234]. An experimental study in mice found that a subset of integrin  $\beta 7+$  gut intraepithelial T lymphocytes within the small intestine enterocyte layer modulates systemic metabolism in a manner advantageous when food is scarce, but detrimental upon consumption of high fat and sugar diets [279]. This metabolic checkpoint might be therapeutically addressed by modulation of the GIT microbiome, *e.g.* through dietary approaches or prebiotics.

Critical impact of GIT microbiota upon the host immune system had previously been discovered in mice. Murine studies are paramount for the elucidation of basic biological phenomena, but have several limitations. These include conflicting results caused by divergent microbiota, and limited translational research value. Rosshart *et al.* [280] transferred C57BL/6 embryos into wild-type mice thus creating "wildlings." These had natural microbiota and pathogens at all body sites while retaining the well-defined and tractable genetics of the parent inbred strain. The bacterial microbiome, mycobiome, and virome [181, 227-232] of "wildlings" affected their immune landscape in multiple organs. Their gut microbiota outcompeted lab strain microbiota and proved resilient to environmental challenge. "Wildlings", but not the lab mice, phenocopied human immune responses in two preclinical investigations. This landmark study demonstrated that a combined natural microbiota- and pathogen-based model holds promise to enhance the reproducibility of experimental biomedical research and to improve translational success of immunological studies.

Regarding the brain, a series of important experimental studies uncovered hitherto unsuspected bidirectional relationships between gut and brain, challenging the classical view of the central nervous system as an immune-privileged site. These studies identified new specialized immune cell subtypes located to distinct anatomical sites: skull and vertebral bone marrow are myeloid cell reservoirs for meninges and CNS parenchyma [281]; the meninges contain diverse immune cells populations: macrophages, T cells, B cells [282], plasma cells producing IgA essential for defense of the central nervous system [283], and gut-licensed NK cells driving anti-inflammatory astrocytes [284]. Furthermore, host GIT microbiota constantly control maturation and function of microglia in the CNS [285-289]. They are also capable to reversibly modulate behavioral and physiological anomalies associated with neuroinflammation [280, 290-292].

Fig. 6 provides a synopsis of the novel players in CVD innate immunity discussed so far (noncoding genome/epigenome, cardiotropic viruses, brain – immune system and gut-brain-immunity axis).

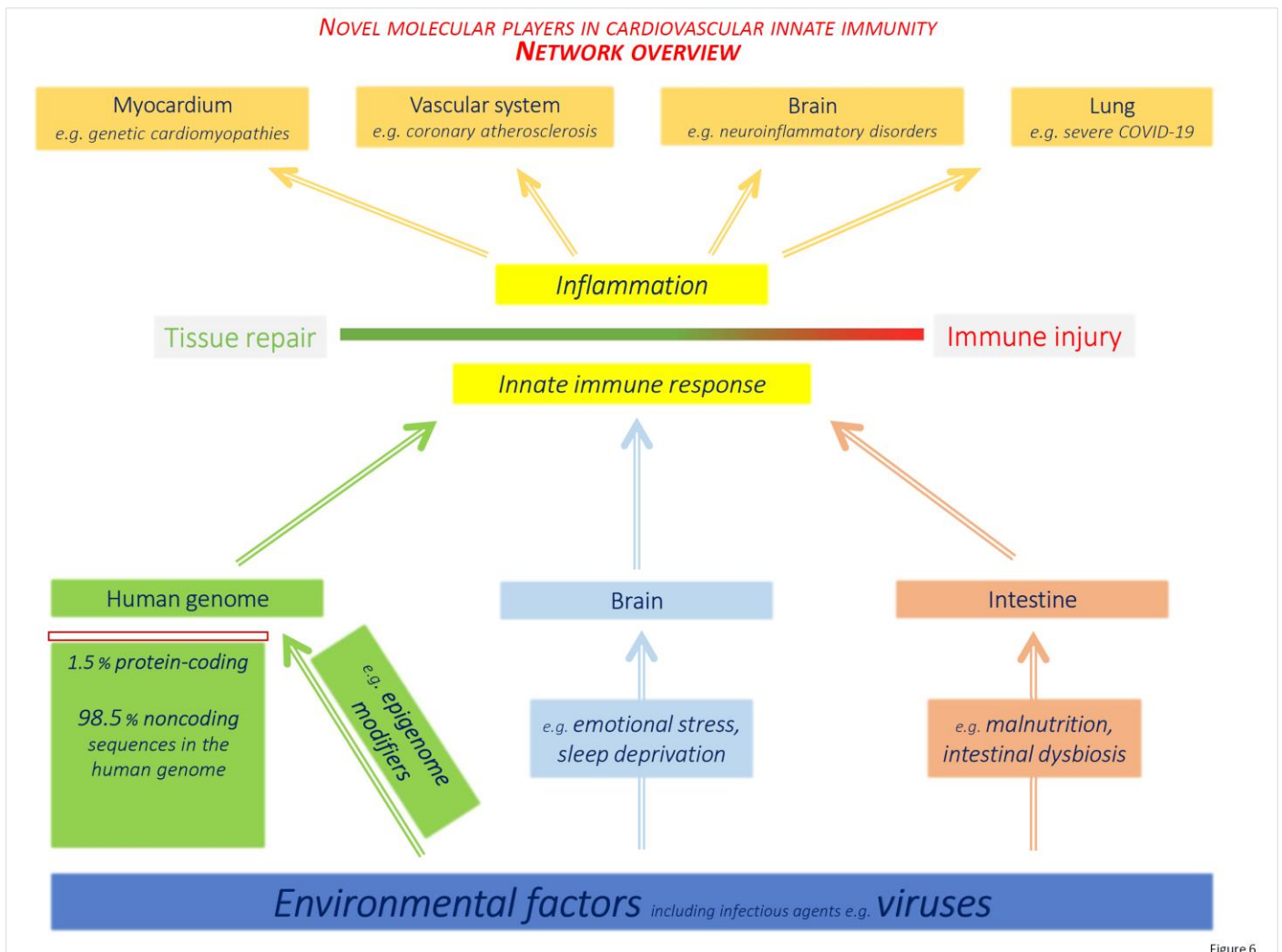

Figure 6

Figure 6. Novel molecular players in cardiovascular innate immunity – an overview of systems involved

## 5. Clinical perspectives of recent studies into novel immune mechanisms

### 5.1. Recognition of high genetic risk for severe COVID-19 or cardiovascular involvement

One of the most vexing feature of SARS-CoV-2 infections [293] is the extraordinary variability of clinical consequences, ranging from asymptomatic to pneumonia and acute respiratory distress syndrome. Of course, variable clinical course is common in diverse viral diseases, but rarely to such an extent as observed with SARS-CoV-2. Established host factors such as high age or body-mass index or concomitant diseases correlate with disease severity, but do not explain all of the variability observed across individuals. These observations have driven most extensive research into genetic factors contributing to COVID-19 susceptibility and severity [157, 164-167, 188-195], and the goal to identify otherwise healthy individuals at high genetic risk will persist despite any progress for prophylaxis or treatment options so far. Knowledge of particularly high individual risk would require and possibly enable tailor-made approaches towards these individuals. From the clinical perspective, none of the molecular genetic risk factors identified so far (chapter 3.2) has entered day-to-day outpatient or clinical practice.

### 5.2. Inflammation as therapeutic target in life-threatening arrhythmias and heart failure

Anomalous immune activation and macrophages are involved in multiple types of cardiomyopathies. From a clinical perspective, there are multiple obstacles to unequivocal detection of myocardial inflammation as a precipitating factor for life-threatening arrhythmias or cardiac remodeling and failure. Even in narrowly focused patient cohorts for whom genetic predisposition is suspected—such as by detection of pathogenic variants—this requires significant additional diagnostic work-up (cardiac MRI, EMB, PET-CT), which may not be feasible in all cases. It is highly likely that only a small fraction of all inflammation-triggered arrhythmic events or progressive heart failure will be clinically detected, generating a blind spot regarding the potential of anti-inflammatory treatments in this context. Notably, anti-arrhythmic potential of immunosuppression does not rely on genetic SCN5A variants because inflammation *per se* may cause dysfunction of normal SCN5A channels, generating a broader clinical incentive to follow this line of research. In view of possible therapeutic relevance, it appears recommendable to further evaluate the hypothesis of independent immunologic risk in major SCN5A variant-carrier cohorts [23]. For further in-depth discussion of recent approaches towards the potential of immunomodulating therapies in human cardiomyopathies we may refer the reader to a recent review covering the field from classical inflammatory cardiomyopathies to immune-checkpoint inhibitor-associated and SARS-CoV-2-associated myocardial inflammation [27].

### 5.3. Remaining clinical challenges in gastrointestinal microbiome and neuroimmune stress research

The novel immune pathomechanisms at organ and systemic level discussed in section 4 have certainly opened new avenues for clinical research. Experimental studies have documented significant impact of the gut microbiome and gut-brain-axis upon remote inflammation in cardiovascular system and brain. The rationale for the use of microbiota-directed therapies in these disorders is obvious, a clinical pilot trial was recently published [234], but final support from stringent clinical trials is not yet available. Within the field of psychoneuroimmunology, recent landmark experimental studies employing advanced genetic and neurosurgical methods have provided novel mechanistic insights into adverse immune impact resulting from different types of stress. Remarkable is their elucidation of differential impact arising from defined brain areas and neuroimmune pathways. Translational evaluation of possible relevance and clinical evaluation in cardiovascular medicine is awaited.

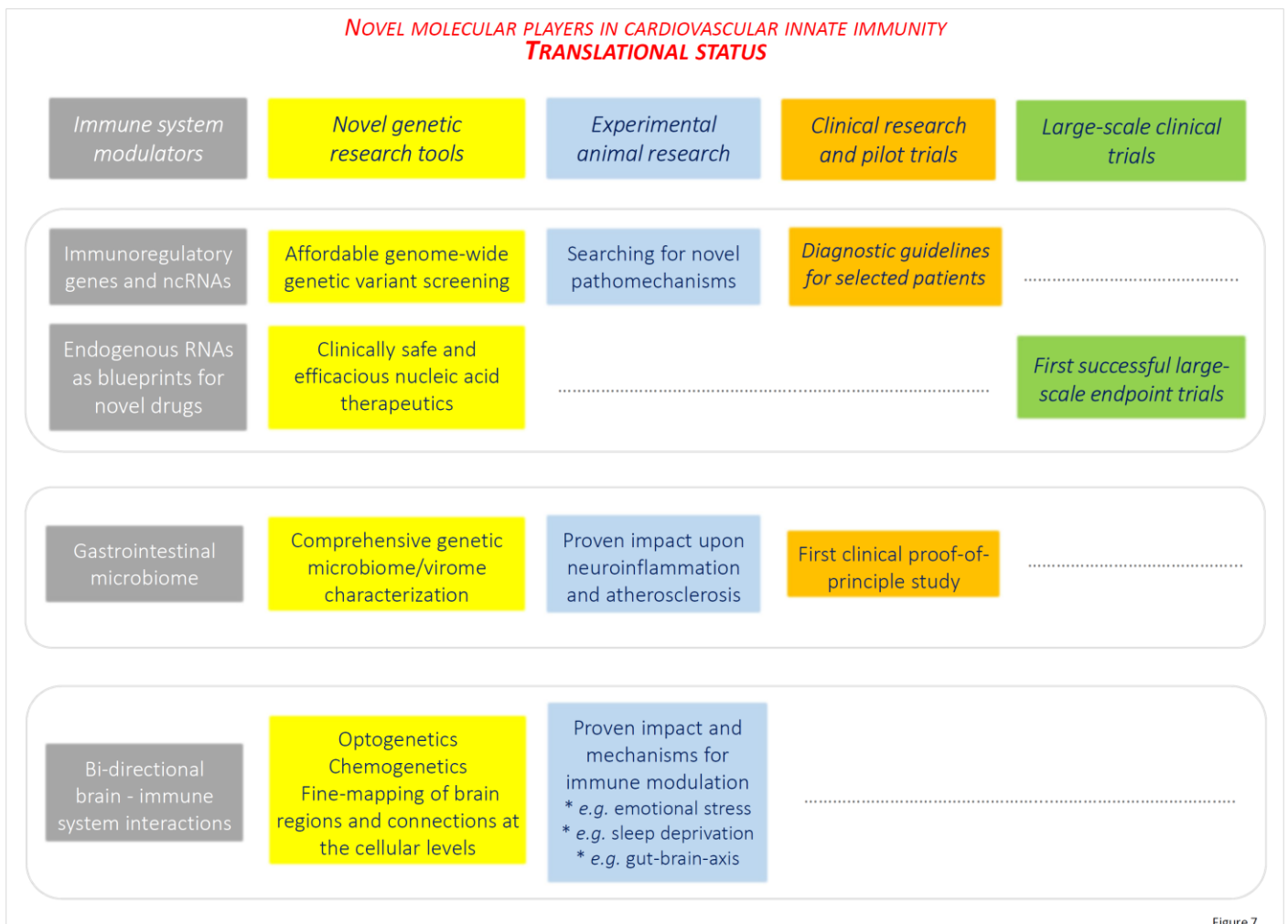

**Figure 7.** Clinical translational status of the research fields.

## 6. Clinical perspectives

While multiple excellent recent reviews have addressed diverse important aspects of immunological research into cardiovascular disorders, we have deliberately focused on selected studies characterized by their use of particularly advanced methodology in pre-clinical or clinical settings. Due to the immense worldwide efforts in the field during the past years the present review cannot be comprehensive, but instead tries to convey an up-to-date perspective on promising developments which may shape research at the crossroads of cardiology – immunology - neurology. During the next few years extensive use of the new research tools should lead to a deeper understanding of the processes at these crossroads, long recognized, but still far from being fully exploited in clinical medicine. Although several challenges need to be overcome before the full impact of these far-reaching new findings will hit the clinical arena, the above reviewed studies already exemplify an overarching aspect *i.e.* its interdisciplinary character of work to come.

## Figure legends

### Figure 1 - New research areas for cardiovascular diseases immunity

Several rapidly expanding research fields investigating cardiovascular innate immunity require logistic and advanced technological cooperation between the disciplines of genetics, neurology, microbiology, and immunology. Interdisciplinary use of the powerful new research tools should lead to deeper understanding of the processes governing cardiovascular immunopathogenesis. We try to convey a perspective on promising developments at the crossroads of cardiology – immunology – neurology. Whatever the ultimate clinical impact of research in these fields, an obvious overarching aspect is the interdisciplinary character of work to come.

### NEW Figure 2 - Cellular receptors and signaling pathways linking innate immunity with cardiovascular diseases

Pattern recognition receptors (PRRs) play a critical role in the activation of an innate immune response to invading pathogens *e.g.* viruses (Fig. 5) or mutant or otherwise modified endogenous structures. PRRs enable recognition of pathogen-associated molecular patterns (PAMPs), or of endogenous molecules released from injured cells and tissue designated damage-associated molecular patterns (DAMPs), acting as PRR ligands. Ligand-PRR interaction then triggers intracellular signalling pathways ultimately inducing expression and release of a multitude of pro-inflammatory or antiviral cytokines.

PRRs may be associated with the cell membrane (*e.g.* 10 Toll-like receptors - TLRs; C-type lectin receptors - CLRs), located within the cytosol (23 NOD-like receptors – NLRs; 3 three RIG-like receptors – RLRs), or in specialized intracellular compartments such as endosomes particularly relevant in viral infections (TLRs 3, 7, 8, 9)(Fig. 5). These PRRs are characterized by a variable number of ligand-sensing (LRR) at their N-terminal (TLRs) or C-terminal (NLRs) ends, and one or more protein-protein interaction (TIR, CARD, PYR) or oligomerization (NACHT) domains. NLRs are also involved in the formation of inflammasomes, a molecular machine activating inflammatory processes including programmed cell death.

While our understanding of the highly complex multiscale signalling network of innate immunity [294] is incomplete, a number of components have been elucidated in considerable detail. Here we may refer to excellent reviews addressing PRRs of particular interest for cardiovascular medicine [20, 295] (TLRs, NLRP3 – inflammasome pathway, IL-1 to IL-6 pathway). Within the context of our review, Fig. 2 shall display well-established classical players of the innate immune system to which several novel components (*e.g.* immunomodulating miRs or lncRNAs) may be added (Fig. 3).

### NEW Figure 3 – Key features of the human noncoding genome and epigenome and suggested novel therapeutic targets therein

*Panel A:* About 99% of the human genome does not encode proteins, but are transcriptionally highly active and give rise to a broad spectrum of ncRNAs with regulatory and structural functions. The observation of a steeply increasing fraction of non-coding RNAs (ncRNAs), in contrast to the modest increase in the number of protein-coding genes during evolution from simple organisms to humans, suggests a major role of ncRNAs in humans. ncRNAs including microRNAs (miRs), small interference RNAs (siRNAs), or long non-coding RNAs (lncRNAs) are involved in the maintenance of cellular homeostasis and the innate immune response to tissue injury or infection. *Panel B:* While many questions regarding the overall impact of the noncoding genome upon human health and disease are still unanswered [61, 62, 296], available experimental and clinical evidence so far suggests a limited number of miRs (miR-17-92 cluster, miR-21, miR-142, miRNA-146a, miR-155, miR-181, miR-223) [297] and lncRNAs [1, 2, 298] may

constitute therapeutic targets in cardiovascular diseases. For each individual target, however, this depends on ensuring efficient drug targeting and clinical safety [106]. *Panel C: Experimental studies [299] shed first light upon therapeutic targeting of the epigenome epigenetics in the context of heart failure. While epigenetic modification is a highly interesting field of research, it should be emphasized [2] that epigenetic modifications are likely to result in pleiotropic actions making clinical translation particularly challenging. (modified from ref. 1 and 2 by permission of Eur. Heart J.)*

**NEW Figure 4** – Novel nucleic acid therapeutics targeting conventional protein-coding genes or noncoding RNA targets

Cardiovascular RNA drugs address multiple organ systems. RNA drugs do not need to address heart (A) or vasculature (B) directly. Instead, primarily liver-targeted RNA drugs (C) are the currently most successful development in the cardiovascular field. Another group of strategies addresses the immune system (D), in particular monocytes-macrophages. 'Carrier' denotes a synthetic nanoparticle and/or receptor ligand employed to deliver an RNA drug to its tissue target. 'Carrier' is bound to and serves to stabilize the RNA drug within the circulation, and to endow it with at least partial selectivity for the target cells, in order to minimize side effects. 'AAV9' denotes a cardiac-targeting recombinant adeno-associated viral vector containing a genome from which the therapeutic RNA sequence is continuously transcribed. Molecular targets: apo(a), apolipoprotein (a); CCR2, chemokine C-C motif receptor 2; CHAST, Cardiac hypertrophy associated transcript; PCSK9, proprotein convertase subtilisin/kexin type 9; PLB, phospholamban. *(modified from ref. 1 and 2 by permission of Eur. Heart J.)*

**NEW Figure 5** - Cellular receptors and signaling pathways linking innate immunity with cardiovascular diseases

Depicted are the most abundant cardiotropic viruses, as well as SARS-CoV-2, and their molecular entry mechanism into cardiovascular cells in the heart. CVB-3 and ADV enter cardiomyocytes *via* binding the transmembrane CAR. In addition, decay-accelerating factor serves as CVB-3 receptor. Integrins ( $\alpha\beta3$  and  $\alpha\beta5$ ) promote ADV internalization. B19V targets endothelial cells by binding to erythrocyte P antigen and integrin  $\alpha\beta1$  as co-receptor. EBV efficiently infects resting human B lymphocytes, whereas HHV6 primarily targets CD4+ T lymphocytes. Using CD46 as cellular receptor, HHV6 can directly infect endothelial cells and subsequently enter adjacent tissues. SARS-CoV-2 cellular entry involves specific binding to the ACE2 receptor as well as proteolytic cleavage by the host cell surface serine protease TMPRSS2. For SARS-CoV-2, several cardiac targets including vascular endothelial cells and cardiomyocytes are proposed. Moreover, pulmonary-derived macrophages are suggested carrying the virus into the myocardium. As a consequence of receptor-dependent cellular entry through the endo-lysosomal pathway, a TLR innate immune signalling cascade is initiated, followed by infiltration by inflammatory cells (T and B lymphocytes, natural killer cells, bone-marrow derived monocytes) which differentiate into M1 and M2 macrophages. ds, double stranded; ss, single-stranded. *(modified from ref. 158 by permission of Cardiovasc. Res.)*

**Figure 6** – Novel players in cardiovascular innate immunity – Systems overview

Several systems acting through innate immunity upon cardiovascular diseases have come under intense scrutiny taking advantage of advanced research tools. (1) Novel molecular components of the human noncoding genome and epigenome emerged as modulators of immunity acting through non-canonical pathways. (2) The intestinal immune system and microbiome exert far-reaching impact upon distant tissues (cardiovascular system, brain). (3) Brain – immune system interaction networks are becoming revealed at unprecedented resolution. (4) Classical environmental risk factors *e.g.* psychosocial stress or viral infections are under intense investigation again triggered by the SARS-CoV-2 pandemic with

major direct and indirect impact upon cardiovascular health. In all of these fields recent insights into human molecular genetics as well as advanced genetic research tools made major contributions.

**Figure 7** – Translational status of research into novel players of cardiovascular innate immunity

This final graph critically summarizes the clinical translational status of insights from the novel research fields, classified from experimental animal studies, through clinical research and pilot trials, to large scale clinical trials. Among the research fields, molecular genetics has made considerable contributions to improve clinical diagnostics and therapy within and beyond cardiovascular medicine.

**Key messages**

- Practice-ready affordable advanced genetic diagnostics has entered clinical practice and is continuously providing important insights not only into an individual's genetic risk, but may also uncover new pathomechanisms suitable to individualize therapy.
- After decades of experimental and translational work, progress from traditional pharmacological towards nucleic acid-based therapies for cardiovascular diseases has been achieved. Insights from basic genetic research (RNA interference, antisense drugs, CRISPR-Cas) are emerging fruitful for clinical medicine.
- Fundamentally improved understanding of the intestinal immune system and microbiome with experimental evidence for far-reaching immune impact upon cardiovascular system and brain has triggered clinical trials evaluating the potential of microbiome modulation.
- The rapidly evolving field of neuroimmunology has identified novel brain – immune system interaction networks revealed at unprecedented resolution, and documented grave adverse impact of stress upon cardiovascular and virological diseases.

**Abbreviations**

ASO	-	antisense oligonucleotide
CVD	-	cardiovascular diseases
CRISPR	-	CRISPR - Cas9 system
DAMP	-	damage-associated molecular pattern
lncRNA	-	long noncoding RNA
miR	-	microRNA
ncRNA	-	noncoding RNA
NLR	-	NOD-like receptor
PAMP	-	pathogen-associated molecular pattern
PRR	-	pattern recognition receptor
RLR	-	RIG-like receptor
RNAi	-	RNA interference
SCN5A	-	SCN5A sodium channel
TLR	-	Toll-like receptor

**Author Contributions:** Conceptualization and original draft preparation: Wolfgang Poller; Writing review and editing “molecular genetics”: Ana Tzvetkova, Andreas Kuss; Writing review and editing “COVID-19”: Bettina Heidecker, Carsten Skurk; Writing review and editing “intestine immunobiology”: Arash Haghikia

**Writing review and editing “brain-immune system interactions”:** Wolfram C. Poller; All authors have read and agreed to the published version of the manuscript

**Funding:** This research received no external funding

**Institutional Review Board Statement:** Not applicable

**Informed Consent Statement:** Not applicable

**Data Availability Statement:** Not applicable

**Acknowledgments:** Administrative support by Charite-Universitätsmedizin Berlin

**Conflicts of Interest:** None

## References

1. Poller, W.; Dimmeler, S.; Heymans, S.; Zeller, T.; Haas, J.; Karakas, M.; Leistner, D. M.; Jakob, P.; Nakagawa, S.; Blankenberg, S.; Engelhardt, S.; Thum, T.; Weber, C.; Meder, B.; Hajjar, R.; Landmesser, U., Non-coding RNAs in cardiovascular diseases: diagnostic and therapeutic perspectives. *Eur Heart J* **2018**, *39*, (29), 2704-2716.
2. Landmesser, U.; Poller, W.; Tsimikas, S.; Most, P.; Paneni, F.; Luscher, T. F., From traditional pharmacological towards nucleic acid-based therapies for cardiovascular diseases. *Eur Heart J* **2020**, *41*, (40), 3884-3899.
3. Grune, J.; Lewis, A. J. M.; Yamazoe, M.; Hulsmans, M.; Rohde, D.; Xiao, L.; Zhang, S.; Ott, C.; Calcagno, D. M.; Zhou, Y.; Timm, K.; Shanmuganathan, M.; Poulos, F. E.; Schloss, M. J.; Foy, B. H.; Capen, D.; Vinegoni, C.; Wojtkiewicz, G. R.; Iwamoto, Y.; Grune, T.; Brown, D.; Higgins, J.; Ferreira, V. M.; Herring, N.; Channon, K. M.; Neubauer, S.; Oxford Acute Myocardial Infarction, S.; Sosnovik, D. E.; Milan, D. J.; Swirski, F. K.; King, K. R.; Aguirre, A. D.; Ellinor, P. T.; Nahrendorf, M., Neutrophils incite and macrophages avert electrical storm after myocardial infarction. *Nat Cardiovasc Res* **2022**, *1*, (7), 649-664.
4. Ammirati, E.; Raimondi, F.; Piriou, N.; Infirri, L. S.; Mohiddin, S. A.; Mazzanti, A.; Shenoy, C.; Cavallari, U. A.; Imazio, M.; Aquaro, G. D.; Olivotto, I.; Pedrotti, P.; Sekhri, N.; Van de Heyning, C. M.; Broeckx, G.; Peretto, G.; Guttman, O.; DelleGrottaglie, S.; Scatteia, A.; Gentile, P.; Merlo, M.; Goldberg, R. I.; Reyentovich, A.; Sciamanna, C.; Klaassen, S.; Poller, W.; Trankle, C. R.; Abbate, A.; Keren, A.; Cederboim, S. H.; Cadrin-Tourigny, J.; Tadros, R.; Annoni, G. A.; Bonoldi, E.; Toquet, C.; Marteau, L.; Probst, V.; Trochu, J. N.; Kissopoulou, A.; Grosu, A.; Kukavica, D.; Trancuccio, A.; Gil, C.; Tini, G.; Pedrazzini, M.; Torchio, M.; Sinagra, G.; Gimeno, J. R.; Bernasconi, D.; Valsecchi, M. G.; Klingel, K.; Adler, E. D.; Camici, P. G.; Cooper, L. T., Acute Myocarditis Associated With Desmosomal Gene Variants. *JACC : Heart Failure* **2022**, in press.
5. Belkaya, S.; Kontorovich, A. R.; Byun, M.; Mulero-Navarro, S.; Bajolle, F.; Cobat, A.; Josowitz, R.; Itan, Y.; Quint, R.; Lorenzo, L.; Boucherit, S.; Stoven, C.; Di Filippo, S.; Abel, L.; Zhang, S. Y.; Bonnet, D.; Gelb, B. D.; Casanova, J. L., Autosomal Recessive Cardiomyopathy Presenting as Acute Myocarditis. *J Am Coll Cardiol* **2017**, *69*, (13), 1653-1665.
6. Ammirati, E.; Brambatti, M.; Braun, O. O.; Shah, P.; Cipriani, M.; Bui, Q. M.; Veenis, J.; Lee, E.; Xu, R.; Hong, K. N.; Van de Heyning, C. M.; Perna, E.; Timmermans, P.; Cikes, M.; Brugs, J. J.; Veronese, G.; Minto, J.; Smith, S.; Gjesdal, G.; Gernhofer, Y. K.; Partida, C.; Potena, L.; Masetti, M.; Boschi, S.; Loforte, A.; Jakus, N.; Milicic, D.; Nilsson, J.; De Bock, D.; Sterken, C.; Van den Bossche, K.; Rega, F.; Tran, H.; Singh, R.; Montomoli, J.; Mondino, M.; Greenberg, B.; Russo, C. F.; Pretorius, V.; Liviu, K.; Frigerio, M.; Adler, E. D., Outcome of patients on heart transplant list treated with a continuous-flow left ventricular assist device: Insights from the TRans-Atlantic registry on VAd and TrAnsplant (TRAViATA). *Int J Cardiol* **2021**, *324*, 122-130.
7. Ammirati, E.; Veronese, G.; Brambatti, M.; Merlo, M.; Cipriani, M.; Potena, L.; Sormani, P.; Aoki, T.; Sugimura, K.; Sawamura, A.; Okumura, T.; Pinney, S.; Hong, K.; Shah, P.; Braun, O.; Van de Heyning, C. M.; Montero, S.; Petrella, D.; Huang, F.; Schmidt, M.; Raineri, C.; Lala, A.; Varrenti, M.; Foa, A.; Leone, O.; Gentile, P.; Artico, J.; Agostini, V.; Patel, R.; Garascia, A.; Van Craenenbroeck, E. M.; Hirose, K.; Isotani, A.; Murohara, T.; Arita, Y.; Sionis, A.; Fabris, E.; Hashem, S.; Garcia-Hernando, V.; Oliva, F.; Greenberg, B.; Shimokawa, H.; Sinagra, G.; Adler, E. D.; Frigerio, M.; Camici, P. G., Fulminant Versus Acute Nonfulminant Myocarditis in Patients With Left Ventricular Systolic Dysfunction. *J Am Coll Cardiol* **2019**, *74*, (3), 299-311.
8. Gentile, P.; Merlo, M.; Peretto, G.; Ammirati, E.; Sala, S.; Della Bella, P.; Aquaro, G. D.; Imazio, M.; Potena, L.; Campodonico, J.; Foa, A.; Raafs, A.; Hazebroek, M.; Brambatti, M.; Cercek, A. C.; Nucifora, G.; Shrivastava, S.; Huang, F.; Schmidt, M.; Muser, D.; Van de Heyning, C. M.; Van Craenenbroeck, E.; Aoki, T.; Sugimura, K.; Shimokawa, H.; Cannata, A.; Artico, J.; Porcari, A.; Colopi, M.; Perkan, A.; Bussani, R.; Barbati, G.; Garascia, A.; Cipriani, M.; Agostoni, P.; Pereira, N.; Heymans, S.; Adler, E. D.; Camici, P. G.; Frigerio, M.; Sinagra, G., Post-discharge arrhythmic risk stratification of patients with acute myocarditis and life-threatening ventricular tachyarrhythmias. *Eur J Heart Fail* **2021**, *23*, (12), 2045-2054.

9. Alley, R.; Grizzard, J. D.; Rao, K.; Markley, R.; Trankle, C. R., Inflammatory Episodes of Desmoplakin Cardiomyopathy Masquerading as Myocarditis: Unique Features on Cardiac Magnetic Resonance Imaging. *JACC Cardiovasc Imaging* **2021**, *14*, (7), 1466-1469.
10. Seidel, F.; Laser, K. T.; Klingel, K.; Dartsch, J.; Theisen, S.; Pickardt, T.; Holtgrewe, M.; Gartner, A.; Berger, F.; Beule, D.; Milting, H.; Schubert, S.; Klaassen, S.; Kuhnisch, J., Pathogenic Variants in Cardiomyopathy Disorder Genes Underlie Pediatric Myocarditis-Further Impact of Heterozygous Immune Disorder Gene Variants? *J Cardiovasc Dev Dis* **2022**, *9*, (7).
11. Seidel, F.; Holtgrewe, M.; Al-Wakeel-Marquard, N.; Opgen-Rhein, B.; Dartsch, J.; Herbst, C.; Beule, D.; Pickardt, T.; Klingel, K.; Messroghli, D.; Berger, F.; Schubert, S.; Kuhnisch, J.; Klaassen, S., Pathogenic Variants Associated With Dilated Cardiomyopathy Predict Outcome in Pediatric Myocarditis. *Circ Genom Precis Med* **2021**, *14*, (4), e003250.
12. Augusto, J. B.; Eiros, R.; Nakou, E.; Moura-Ferreira, S.; Treibel, T. A.; Captur, G.; Akhtar, M. M.; Protonotarios, A.; Gossios, T. D.; Savvatis, K.; Syrris, P.; Mohiddin, S.; Moon, J. C.; Elliott, P. M.; Lopes, L. R., Dilated cardiomyopathy and arrhythmogenic left ventricular cardiomyopathy: a comprehensive genotype-imaging phenotype study. *Eur Heart J Cardiovasc Imaging* **2020**, *21*, (3), 326-336.
13. Mueller, M.; Zwinger, L.; Klaassen, S.; Poller, W.; Monserrat Iglesias, L.; Pablo Ochoa, J.; Klingel, K.; Landmesser, U.; Heidecker, B., Severe heart failure in the setting of inflammatory cardiomyopathy with likely pathogenic titin variant. *Int J Cardiol Heart Vasc* **2022**, *39*, 100969.
14. Violano, M.; Poller, W.; Abraham, M. R.; Huemer, M.; Scheinman, M.; Landmesser, U.; Heidecker, B., Deadly emotional argument: Sudden cardiac death in catecholaminergic polymorphic ventricular tachycardia (CPVT). *Int J Cardiol Heart Vasc* **2022**, *41*, 101062.
15. Gerhardt, T.; Monserrat, L.; Landmesser, U.; Poller, W., A novel Troponin I mutation associated with severe restrictive cardiomyopathy-a case report of a 27-year-old woman with fatigue. *Eur Heart J Case Rep* **2022**, *6*, (2), yta053.
16. Musunuru, K.; Hershberger, R. E.; Day, S. M.; Klinedinst, N. J.; Landstrom, A. P.; Parikh, V. N.; Prakash, S.; Semsarian, C.; Sturm, A. C.; American Heart Association Council on, G.; Precision, M.; Council on Arteriosclerosis, T.; Vascular, B.; Council on, C.; Stroke, N.; Council on Clinical, C., Genetic Testing for Inherited Cardiovascular Diseases: A Scientific Statement From the American Heart Association. *Circ Genom Precis Med* **2020**, *13*, (4), e000067.
17. Ortega-Vega, E. L.; Guzman-Castaneda, S. J.; Campo, O.; Velasquez-Mejia, E. P.; de la Cuesta-Zuluaga, J.; Bedoya, G.; Escobar, J. S., Variants in genes of innate immunity, appetite control and energy metabolism are associated with host cardiometabolic health and gut microbiota composition. *Gut Microbes* **2019**, 1-13.
18. Mueller, M.; Poller, W.; Klingel, K.; Neumann, T.; Landmesser, U.; Heidecker, B., Eosinophilic granulomatosis with polyangiitis (EGPA) with low activity EBV replication during the COVID 19 pandemic. *Int J Cardiol Heart Vasc* **2022**, *39*, 100968.
19. Poller, W.; Skurk, C.; Escher, F.; Manes, C.; Elgeti, T.; Schultheiss, H. P.; Taupitz, M.; Landmesser, U., Multimodality Imaging Reveals Divergent Responses of Left and Right Heart to Treatment in Cardiac Amyloidosis. *JACC Case Rep* **2019**, *1*, (3), 360-366.
20. Jaen, R. I.; Val-Blasco, A.; Prieto, P.; Gil-Fernandez, M.; Smani, T.; Lopez-Sendon, J. L.; Delgado, C.; Bosca, L.; Fernandez-Velasco, M., Innate Immune Receptors, Key Actors in Cardiovascular Diseases. *JACC Basic Transl Sci* **2020**, *5*, (7), 735-749.
21. Fernandez-Ruiz, I., Immune system and cardiovascular disease. *Nat Rev Cardiol* **2016**, *13*, (9), 503.
22. Poller, W.; Haas, J.; Klingel, K.; Kuhnisch, J.; Gast, M.; Kaya, Z.; Escher, F.; Kayvanpour, E.; Degener, F.; Opgen-Rhein, B.; Berger, F.; Mochmann, H. C.; Skurk, C.; Heidecker, B.; Schultheiss, H. P.; Monserrat, L.; Meder, B.; Landmesser, U.; Klaassen, S., Familial Recurrent Myocarditis Triggered by Exercise in Patients With a Truncating Variant of the Desmoplakin Gene. *J Am Heart Assoc* **2020**, *9*, (10), e015289.
23. Poller, W.; Escher, F.; Haas, J.; Heidecker, B.; Schultheiss, H. P.; Attanasio, P.; Skurk, C.; Haghikia, A.; Meder, B.; Klaassen, S., Missense Variant E1295K of Sodium Channel SCN5A Associated With Recurrent Ventricular Fibrillation and Myocardial Inflammation. *JACC Case Rep* **2022**, *4*, (5), 280-286.
24. Lota, A. S.; Hazebroek, M. R.; Theotokis, P.; Wassall, R.; Salmi, S.; Halliday, B. P.; Tayal, U.; Verdonschot, J.; Meena, D.; Owen, R.; de Marvao, A.; Iacob, A.; Yazdani, M.; Hammersley, D. J.; Jones, R. E.; Wage, R.; Buchan, R.; Vivian, F.; Hafouda, Y.; Nosedá, M.; Gregson, J.; Mittal, T.; Wong, J.; Robertus, J. L.; Baksi, J.; Vassiliou, V.; Tzoulaki, I.; Pantazis, A.; Cleland, J. G. F.; Barton, P. J. R.; Cook, S. A.; Pennell, D. J.; Garcia-Pavia, P.; Cooper, L. T.; Heymans, S.; Ware, J. S.; Prasad, S. K., Genetic Architecture of Acute Myocarditis and the Overlap With Inherited Cardiomyopathy. *Circulation* **2022**, 146.
25. Jones, A.; Kainz, D.; Khan, F.; Lee, C.; Carrithers, M. D., Human macrophage SCN5A activates an innate immune signaling pathway for antiviral host defense. *J Biol Chem* **2014**, *289*, (51), 35326-40.
26. Rahgozar, K.; Wright, E.; Carrithers, L. M.; Carrithers, M. D., Mediation of protection and recovery from experimental autoimmune encephalomyelitis by macrophages expressing the human voltage-gated sodium channel NaV1.5. *J Neuropathol Exp Neurol* **2013**, *72*, (6), 489-504.
27. Ammirati, E.; Bizzi, E.; Veronese, G.; Groh, M.; Van de Heyning, C. M.; Lehtonen, J.; Pineton de Chambrun, M.; Cereda, A.; Picchi, C.; Trotta, L.; Moslehi, J. J.; Brucato, A., Immunomodulating Therapies in Acute Myocarditis and Recurrent/Acute Pericarditis. *Front Med (Lausanne)* **2022**, *9*, 838564.

28. Zhao, Y.; Liu, Y. S., Longevity Factor FOXO3: A Key Regulator in Aging-Related Vascular Diseases. *Front Cardiovasc Med* **2021**, *8*, 778674.
29. Calissi, G.; Lam, E. W.; Link, W., Therapeutic strategies targeting FOXO transcription factors. *Nat Rev Drug Discov* **2021**, *20*, (1), 21-38.
30. Lin, L.; Hron, J. D.; Peng, S. L., Regulation of NF-kappaB, Th activation, and autoinflammation by the forkhead transcription factor Foxo3a. *Immunity* **2004**, *21*, (2), 203-13.
31. Dejean, A. S.; Beisner, D. R.; Ch'en, I. L.; Kerdiles, Y. M.; Babour, A.; Arden, K. C.; Castrillon, D. H.; DePinho, R. A.; Hedrick, S. M., Transcription factor Foxo3 controls the magnitude of T cell immune responses by modulating the function of dendritic cells. *Nat Immunol* **2009**, *10*, (5), 504-13.
32. Mouchiroud, L.; Houtkooper, R. H.; Moullan, N.; Katsyuba, E.; Ryu, D.; Canto, C.; Mottis, A.; Jo, Y. S.; Viswanathan, M.; Schoonjans, K.; Guarente, L.; Auwerx, J., The NAD(+)/Sirtuin Pathway Modulates Longevity through Activation of Mitochondrial UPR and FOXO Signaling. *Cell* **2013**, *154*, (2), 430-41.
33. Jonsson, H.; Allen, P.; Peng, S. L., Inflammatory arthritis requires Foxo3a to prevent Fas ligand-induced neutrophil apoptosis. *Nat Med* **2005**, *11*, (6), 666-71.
34. Skurk, C.; Izumiya, Y.; Maatz, H.; Razeghi, P.; Shiojima, I.; Sandri, M.; Sato, K.; Zeng, L.; Schiekofer, S.; Pimentel, D.; Lecker, S.; Taegtmeier, H.; Goldberg, A. L.; Walsh, K., The FOXO3a transcription factor regulates cardiac myocyte size downstream of AKT signaling. *J Biol Chem* **2005**, *280*, (21), 20814-23.
35. Sengupta, A.; Molkentin, J. D.; Paik, J. H.; DePinho, R. A.; Yutzey, K. E., FoxO transcription factors promote cardiomyocyte survival upon induction of oxidative stress. *J Biol Chem* **2011**, *286*, (9), 7468-78.
36. Ferdous, A.; Battiprolu, P. K.; Ni, Y. G.; Rothermel, B. A.; Hill, J. A., FoxO, autophagy, and cardiac remodeling. *J Cardiovasc Transl Res* **2010**, *3*, (4), 355-64.
37. Chiribau, C. B.; Cheng, L.; Cucoranu, I. C.; Yu, Y. S.; Clempus, R. E.; Sorescu, D., FOXO3A regulates peroxiredoxin III expression in human cardiac fibroblasts. *J Biol Chem* **2008**, *283*, (13), 8211-7.
38. Willcox, B. J.; Donlon, T. A.; He, Q.; Chen, R.; Grove, J. S.; Yano, K.; Masaki, K. H.; Willcox, D. C.; Rodriguez, B.; Curb, J. D., FOXO3A genotype is strongly associated with human longevity. *Proc Natl Acad Sci U S A* **2008**, *105*, (37), 13987-92.
39. Bao, J. M.; Song, X. L.; Hong, Y. Q.; Zhu, H. L.; Li, C.; Zhang, T.; Chen, W.; Zhao, S. C.; Chen, Q., Association between FOXO3A gene polymorphisms and human longevity: a meta-analysis. *Asian J Androl* **2014**, *16*, (3), 446-52.
40. Lee, J. C.; Espeli, M.; Anderson, C. A.; Linterman, M. A.; Pocock, J. M.; Williams, N. J.; Roberts, R.; Viatte, S.; Fu, B.; Peshu, N.; Hien, T. T.; Phu, N. H.; Wesley, E.; Edwards, C.; Ahmad, T.; Mansfield, J. C.; Gearry, R.; Dunstan, S.; Williams, T. N.; Barton, A.; Vinuesa, C. G.; Consortium, U. I. G.; Parkes, M.; Lyons, P. A.; Smith, K. G., Human SNP links differential outcomes in inflammatory and infectious disease to a FOXO3-regulated pathway. *Cell* **2013**, *155*, (1), 57-69.
41. Loebel, M.; Holzhauser, L.; Hartwig, J. A.; Shukla, P. C.; Savvatis, K.; Jenke, A.; Gast, M.; Escher, F.; Becker, S. C.; Bauer, S.; Stroux, A.; Beling, A.; Kespohl, M.; Pinkert, S.; Fechner, H.; Kuehl, U.; Lassner, D.; Poller, W.; Schultheiss, H. P.; Zeller, T.; Blankenberg, S.; Papageorgiou, A. P.; Heymans, S.; Landmesser, U.; Scheibebogen, C.; Skurk, C., The forkhead transcription factor Foxo3 negatively regulates natural killer cell function and viral clearance in myocarditis. *Eur Heart J* **2018**, *39*, (10), 876-887.
42. Kespohl, M.; Bredow, C.; Klingel, K.; Voss, M.; Paeschke, A.; Zickler, M.; Poller, W.; Kaya, Z.; Eckstein, J.; Fechner, H.; Spranger, J.; Fahling, M.; Wirth, E. K.; Radoshevich, L.; Thery, F.; Impens, F.; Berndt, N.; Knobloch, K. P.; Beling, A., Protein modification with ISG15 blocks coxsackievirus pathology by antiviral and metabolic reprogramming. *Sci Adv* **2020**, *6*, (11), eaay1109.
43. Rahnefeld, A.; Klingel, K.; Schuermann, A.; Diny, N. L.; Althof, N.; Lindner, A.; Bleienheuft, P.; Savvatis, K.; Respondek, D.; Opitz, E.; Ketscher, L.; Sauter, M.; Seifert, U.; Tschope, C.; Poller, W.; Knobloch, K. P.; Voigt, A., Ubiquitin-like protein ISG15 (interferon-stimulated gene of 15 kDa) in host defense against heart failure in a mouse model of virus-induced cardiomyopathy. *Circulation* **2014**, *130*, (18), 1589-600.
44. Malekos, E.; Carpenter, S., Short open reading frame genes in innate immunity: from discovery to characterization. *Trends Immunol* **2022**.
45. Michieletto, M. F.; Henao-Mejia, J., Ontogeny and heterogeneity of innate lymphoid cells and the noncoding genome. *Immunol Rev* **2021**, *300*, (1), 152-166.
46. Sadeq, S.; Al-Hashimi, S.; Cusack, C. M.; Werner, A., Endogenous Double-Stranded RNA. *Noncoding RNA* **2021**, *7*, (1).
47. Imamura, K.; Imamachi, N.; Akizuki, G.; Kumakura, M.; Kawaguchi, A.; Nagata, K.; Kato, A.; Kawaguchi, Y.; Sato, H.; Yoneda, M.; Kai, C.; Yada, T.; Suzuki, Y.; Yamada, T.; Ozawa, T.; Kaneki, K.; Inoue, T.; Kobayashi, M.; Kodama, T.; Wada, Y.; Sekimizu, K.; Akimitsu, N., Long noncoding RNA NEAT1-dependent SFPQ relocation from promoter region to paraspeckle mediates IL8 expression upon immune stimuli. *Mol Cell* **2014**, *53*, (3), 393-406.

48. Gomez, J. A.; Wapinski, O. L.; Yang, Y. W.; Bureau, J. F.; Gopinath, S.; Monack, D. M.; Chang, H. Y.; Brahic, M.; Kirkegaard, K., The NeST long ncRNA controls microbial susceptibility and epigenetic activation of the interferon-gamma locus. *Cell* **2013**, *152*, (4), 743-54.
49. Collier, S. P.; Henderson, M. A.; Tossberg, J. T.; Aune, T. M., Regulation of the Th1 genomic locus from Ifng through Tmevpg1 by T-bet. *J Immunol* **2014**, *193*, (8), 3959-65.
50. Ouyang, J.; Zhu, X.; Chen, Y.; Wei, H.; Chen, Q.; Chi, X.; Qi, B.; Zhang, L.; Zhao, Y.; Gao, G. F.; Wang, G.; Chen, J. L., NRAV, a long noncoding RNA, modulates antiviral responses through suppression of interferon-stimulated gene transcription. *Cell Host Microbe* **2014**, *16*, (5), 616-26.
51. Ouyang, J.; Hu, J.; Chen, J. L., lncRNAs regulate the innate immune response to viral infection. *Wiley Interdiscip Rev RNA* **2016**, *7*, (1), 129-43.
52. Li, Z.; Chao, T. C.; Chang, K. Y.; Lin, N.; Patil, V. S.; Shimizu, C.; Head, S. R.; Burns, J. C.; Rana, T. M., The long noncoding RNA THRIL regulates TNFalpha expression through its interaction with hnRNPL. *Proc Natl Acad Sci U S A* **2014**, *111*, (3), 1002-7.
53. Plasek, L. M.; Valadkhan, S., lncRNAs in T lymphocytes: RNA regulation at the heart of the immune response. *Am J Physiol Cell Physiol* **2021**, *320*, (3), C415-C427.
54. Spurlock, C. F., 3rd; Tossberg, J. T.; Guo, Y.; Collier, S. P.; Crooke, P. S., 3rd; Aune, T. M., Expression and functions of long noncoding RNAs during human T helper cell differentiation. *Nat Commun* **2015**, *6*, 6932.
55. Wang, P.; Xue, Y.; Han, Y.; Lin, L.; Wu, C.; Xu, S.; Jiang, Z.; Xu, J.; Liu, Q.; Cao, X., The STAT3-binding long noncoding RNA lnc-DC controls human dendritic cell differentiation. *Science* **2014**, *344*, (6181), 310-3.
56. Ranzani, V.; Rossetti, G.; Panzeri, I.; Arrighoni, A.; Bonnal, R. J.; Curti, S.; Gruarin, P.; Provasi, E.; Sugliano, E.; Marconi, M.; De Francesco, R.; Geginat, J.; Bodega, B.; Abrignani, S.; Pagani, M., The long intergenic noncoding RNA landscape of human lymphocytes highlights the regulation of T cell differentiation by linc-MAF-4. *Nat Immunol* **2015**, *16*, (3), 318-325.
57. Dijkstra, J. M.; Alexander, D. B., The "NF-k B interacting long noncoding RNA" (NKILA) transcript is antisense to cancer-associated gene PMEPA1. *F1000Res* **2015**, *4*, 96.
58. Imam, H.; Bano, A. S.; Patel, P.; Holla, P.; Jameel, S., The lncRNA NRON modulates HIV-1 replication in a NFAT-dependent manner and is differentially regulated by early and late viral proteins. *Sci Rep* **2015**, *5*, 8639.
59. Henzinger, H.; Barth, D. A.; Klec, C.; Pichler, M., Non-Coding RNAs and SARS-Related Coronaviruses. *Viruses* **2020**, *12*, (12).
60. Zhu, L.; Lin, X.; Chen, M., lncRNA NEAT1 correlates with Th17 cells and proinflammatory cytokines, also reflects stenosis degree and cholesterol level in coronary heart disease patients. *J Clin Lab Anal* **2022**, *36*, (6), e23975.
61. Wilusz, J. E., Long noncoding RNAs: Re-writing dogmas of RNA processing and stability. *Biochim Biophys Acta* **2016**, *1859*, (1), 128-38.
62. Ponting, C. P.; Haerty, W., Genome-Wide Analysis of Human Long Noncoding RNAs: A Provocative Review. *Annu Rev Genomics Hum Genet* **2022**, *23*, 153-172.
63. Suckau, L.; Fechner, H.; Chemaly, E.; Krohn, S.; Hadri, L.; Kockskamper, J.; Westermann, D.; Bisping, E.; Ly, H.; Wang, X.; Kawase, Y.; Chen, J.; Liang, L.; Sipo, I.; Vetter, R.; Weger, S.; Kurreck, J.; Erdmann, V.; Tschöpe, C.; Pieske, B.; Lebeche, D.; Schultheiss, H. P.; Hajjar, R. J.; Poller, W. C., Long-term cardiac-targeted RNA interference for the treatment of heart failure restores cardiac function and reduces pathological hypertrophy. *Circulation* **2009**, *119*, (9), 1241-52.
64. Fechner, H.; Sipo, I.; Westermann, D.; Pinkert, S.; Wang, X.; Suckau, L.; Kurreck, J.; Zeichhardt, H.; Müller, O.; Vetter, R.; Erdmann, V.; Tschöpe, C.; Poller, W., Cardiac-targeted RNA interference mediated by an AAV9 vector improves cardiac function in coxsackievirus B3 cardiomyopathy. *J Mol Med (Berl)* **2008**, *86*, (9), 987-97.
65. Bonauer, A.; Carmona, G.; Iwasaki, M.; Mione, M.; Koyanagi, M.; Fischer, A.; Burchfield, J.; Fox, H.; Doebele, C.; Ohtani, K.; Chavakis, E.; Potente, M.; Tjwa, M.; Urbich, C.; Zeiher, A. M.; Dimmeler, S., MicroRNA-92a controls angiogenesis and functional recovery of ischemic tissues in mice. *Science* **2009**, *324*, (5935), 1710-3.
66. Daniel, J. M.; Penzkofer, D.; Teske, R.; Dutzmann, J.; Koch, A.; Bielenberg, W.; Bonauer, A.; Boon, R. A.; Fischer, A.; Bauersachs, J.; van Rooij, E.; Dimmeler, S.; Sedding, D. G., Inhibition of miR-92a improves re-endothelialization and prevents neointima formation following vascular injury. *Cardiovasc Res* **2014**, *103*, (4), 564-72.
67. Thum, T.; Gross, C.; Fiedler, J.; Fischer, T.; Kissler, S.; Bussen, M.; Galuppo, P.; Just, S.; Rottbauer, W.; Frantz, S.; Castoldi, M.; Soutschek, J.; Koteliangsky, V.; Rosenwald, A.; Basson, M. A.; Licht, J. D.; Pena, J. T.; Rouhanifard, S. H.; Muckenthaler, M. U.; Tuschl, T.; Martin, G. R.; Bauersachs, J.; Engelhardt, S., MicroRNA-21 contributes to myocardial disease by stimulating MAP kinase signalling in fibroblasts. *Nature* **2008**, *456*, (7224), 980-4.
68. Sassi, Y.; Avramopoulos, P.; Ramanujam, D.; Gruter, L.; Werfel, S.; Giosele, S.; Brunner, A. D.; Esfandyari, D.; Papadopoulou, A. S.; De Strooper, B.; Hubner, N.; Kumarswamy, R.; Thum, T.; Yin, X.; Mayr, M.; Laggerbauer, B.; Engelhardt, S., Cardiac myocyte miR-29 promotes pathological remodeling of the heart by activating Wnt signaling. *Nat Commun* **2017**, *8*, (1), 1614.

69. Ganesan, J.; Ramanujam, D.; Sassi, Y.; Ahles, A.; Jentzsch, C.; Werfel, S.; Leierseder, S.; Loyer, X.; Giacca, M.; Zentilin, L.; Thum, T.; Laggerbauer, B.; Engelhardt, S., MiR-378 controls cardiac hypertrophy by combined repression of mitogen-activated protein kinase pathway factors. *Circulation* **2013**, *127*, (21), 2097-106.
70. Janssen, H. L.; Reesink, H. W.; Lawitz, E. J.; Zeuzem, S.; Rodriguez-Torres, M.; Patel, K.; van der Meer, A. J.; Patick, A. K.; Chen, A.; Zhou, Y.; Persson, R.; King, B. D.; Kauppinen, S.; Levin, A. A.; Hodges, M. R., Treatment of HCV infection by targeting microRNA. *N Engl J Med* **2013**, *368*, (18), 1685-94.
71. Corsten, M. F.; Papageorgiou, A.; Verhesen, W.; Carai, P.; Lindow, M.; Obad, S.; Summer, G.; Coort, S. L.; Hazebroek, M.; van Leeuwen, R.; Gijbels, M. J.; Wijnands, E.; Biessen, E. A.; De Winther, M. P.; Stassen, F. R.; Carmeliet, P.; Kauppinen, S.; Schroen, B.; Heymans, S., MicroRNA profiling identifies microRNA-155 as an adverse mediator of cardiac injury and dysfunction during acute viral myocarditis. *Circ Res* **2012**, *111*, (4), 415-25.
72. Foinquinos, A.; Batkai, S.; Genschel, C.; Viereck, J.; Rump, S.; Gyongyosi, M.; Traxler, D.; Riesenhuber, M.; Spannauer, A.; Lukovic, D.; Weber, N.; Zlabinger, K.; Hasimbegovic, E.; Winkler, J.; Fiedler, J.; Dangwal, S.; Fischer, M.; de la Roche, J.; Wojciechowski, D.; Kraft, T.; Garamvolgyi, R.; Neitzel, S.; Chatterjee, S.; Yin, X.; Bar, C.; Mayr, M.; Xiao, K.; Thum, T., Preclinical development of a miR-132 inhibitor for heart failure treatment. *Nat Commun* **2020**, *11*, (1), 633.
73. Hara, R. I.; Hisada, Y.; Maeda, Y.; Yokota, T.; Wada, T., Artificial cationic oligosaccharides for heteroduplex oligonucleotide-type drugs. *Sci Rep* **2018**, *8*, (1), 4323.
74. Farkas, N.; Scaria, P. V.; Woodle, M. C.; Dagata, J. A., Physical-chemical measurement method development for self-assembled, core-shell nanoparticles. *Sci Rep* **2019**, *9*, (1), 1655.
75. Smith, C. I. E.; Zain, R., Therapeutic Oligonucleotides: State of the Art. *Annu Rev Pharmacol Toxicol* **2019**, *59*, 605-630.
76. Yu, A. M.; Choi, Y. H.; Tu, M. J., RNA Drugs and RNA Targets for Small Molecules: Principles, Progress, and Challenges. *Pharmacol Rev* **2020**, *72*, (4), 862-898.
77. Graham, M. J.; Lee, R. G.; Brandt, T. A.; Tai, L. J.; Fu, W.; Peralta, R.; Yu, R.; Hurh, E.; Paz, E.; McEvoy, B. W.; Baker, B. F.; Pham, N. C.; Digenio, A.; Hughes, S. G.; Geary, R. S.; Witztum, J. L.; Crooke, R. M.; Tsimikas, S., Cardiovascular and Metabolic Effects of ANGPTL3 Antisense Oligonucleotides. *N Engl J Med* **2017**, *377*, (3), 222-232.
78. Zlatev, I.; Castoreno, A.; Brown, C. R.; Qin, J.; Waldron, S.; Schlegel, M. K.; Degaonkar, R.; Shulga-Morskaya, S.; Xu, H.; Gupta, S.; Matsuda, S.; Akinc, A.; Rajeev, K. G.; Manoharan, M.; Maier, M. A.; Jadhav, V., Reversal of siRNA-mediated gene silencing in vivo. *Nat Biotechnol* **2018**, *36*, (6), 509-511.
79. Fechner, H.; Suckau, L.; Kurreck, J.; Sipo, I.; Wang, X.; Pinkert, S.; Loschen, S.; Rekkittke, J.; Weger, S.; Dekkers, D.; Vetter, R.; Erdmann, V. A.; Schultheiss, H. P.; Paul, M.; Lamers, J.; Poller, W., Highly efficient and specific modulation of cardiac calcium homeostasis by adenovector-derived short hairpin RNA targeting phospholamban. *Gene Therapy* **2007**, *14*, (3), 211-218.
80. Le, B. T.; Paul, S.; Jastrzebska, K.; Langer, H.; Caruthers, M. H.; Veedu, R. N., Thiomorpholino oligonucleotides as a robust class of next generation platforms for alternate mRNA splicing. *Proc Natl Acad Sci U S A* **2022**, *119*, (36), e2207956119.
81. Hwang, J.; Yokota, T., Recent advancements in exon-skipping therapies using antisense oligonucleotides and genome editing for the treatment of various muscular dystrophies. *Expert Rev Mol Med* **2019**, *21*, e5.
82. Alexander, V. J.; Xia, S.; Hurh, E.; Hughes, S. G.; O'Dea, L.; Geary, R. S.; Witztum, J. L.; Tsimikas, S., N-acetyl galactosamine-conjugated antisense drug to APOC3 mRNA, triglycerides and atherogenic lipoprotein levels. *Eur Heart J* **2019**, *40*, (33), 2785-2796.
83. Iwamoto, N.; Butler, D. C. D.; Svrzikapa, N.; Mohapatra, S.; Zlatev, I.; Sah, D. W. Y.; Meena; Standley, S. M.; Lu, G.; Apponi, L. H.; Frank-Kamenetsky, M.; Zhang, J. J.; Vargeese, C.; Verdine, G. L., Control of phosphorothioate stereochemistry substantially increases the efficacy of antisense oligonucleotides. *Nat Biotechnol* **2017**, *35*, (9), 845-851.
84. Deogharia, M.; Gurha, P., The "guiding" principles of noncoding RNA function. *Wiley Interdiscip Rev RNA* **2022**, *13*, (4), e1704.
85. Ray, K. K.; Wright, R. S.; Kallend, D.; Koenig, W.; Leiter, L. A.; Raal, F. J.; Bisch, J. A.; Richardson, T.; Jaros, M.; Wijngaard, P. L. J.; Kastelein, J. J. P.; Orion; Investigators, O.-. Two Phase 3 Trials of Inclisiran in Patients with Elevated LDL Cholesterol. *N Engl J Med* **2020**, *382*, (16), 1507-1519.
86. Raal, F. J.; Kallend, D.; Ray, K. K.; Turner, T.; Koenig, W.; Wright, R. S.; Wijngaard, P. L. J.; Curcio, D.; Jaros, M. J.; Leiter, L. A.; Kastelein, J. J. P.; Investigators, O.-. Inclisiran for the Treatment of Heterozygous Familial Hypercholesterolemia. *N Engl J Med* **2020**, *382*, (16), 1520-1530.
87. Benson, M. D.; Waddington-Cruz, M.; Berk, J. L.; Polydefkis, M.; Dyck, P. J.; Wang, A. K.; Plante-Bordeneuve, V.; Barroso, F. A.; Merlini, G.; Obici, L.; Scheinberg, M.; Brannagan, T. H., 3rd; Litchy, W. J.; Whelan, C.; Drachman, B. M.; Adams, D.; Heitner, S. B.; Conceicao, I.; Schmidt, H. H.; Vita, G.; Campistol, J. M.; Gamez, J.; Gorevic, P. D.; Gane, E.; Shah, A. M.; Solomon, S. D.; Monia, B. P.; Hughes, S. G.; Kwok, T. J.; McEvoy, B. W.; Jung, S. W.; Baker, B. F.; Ackermann, E. J.; Gertz, M. A.; Coelho, T., Inotersen Treatment for Patients with Hereditary Transthyretin Amyloidosis. *N Engl J Med* **2018**, *379*, (1), 22-31.
88. Gertz, M. A.; Scheinberg, M.; Waddington-Cruz, M.; Heitner, S. B.; Karam, C.; Drachman, B.; Khella, S.; Whelan, C.; Obici, L., Inotersen for the treatment of adults with polyneuropathy caused by hereditary transthyretin-mediated amyloidosis. *Expert Rev Clin Pharmacol* **2019**, *12*, (8), 701-711.

89. Wright, R. S.; Ray, K. K.; Raal, F. J.; Kallend, D. G.; Jaros, M.; Koenig, W.; Leiter, L. A.; Landmesser, U.; Schwartz, G. G.; Friedman, A.; Wijngaard, P. L. J.; Garcia Conde, L.; Kastelein, J. J. P.; Investigators, O. P. I., Pooled Patient-Level Analysis of Inclisiran Trials in Patients With Familial Hypercholesterolemia or Atherosclerosis. *J Am Coll Cardiol* **2021**, *77*, (9), 1182-1193.
90. Ray, K. K.; Landmesser, U.; Leiter, L. A.; Kallend, D.; Dufour, R.; Karakas, M.; Hall, T.; Troquay, R. P.; Turner, T.; Visseren, F. L.; Wijngaard, P.; Wright, R. S.; Kastelein, J. J., Inclisiran in Patients at High Cardiovascular Risk with Elevated LDL Cholesterol. *N Engl J Med* **2017**, *376*, (15), 1430-1440.
91. Ray, K. K.; Stoekenbroek, R. M.; Kallend, D.; Leiter, L. A.; Landmesser, U.; Wright, R. S.; Wijngaard, P.; Kastelein, J. J. P., Effect of an siRNA Therapeutic Targeting PCSK9 on Atherogenic Lipoproteins. *Circulation* **2018**, *138*, (13), 1304-1316.
92. Ray, K. K.; Stoekenbroek, R. M.; Kallend, D.; Nishikido, T.; Leiter, L. A.; Landmesser, U.; Wright, R. S.; Wijngaard, P. L. J.; Kastelein, J. J. P., Effect of 1 or 2 Doses of Inclisiran on Low-Density Lipoprotein Cholesterol Levels: One-Year Follow-up of the ORION-1 Randomized Clinical Trial. *JAMA Cardiol* **2019**, *4*, (11), 1067-1075.
93. Witztum, J. L.; Gaudet, D.; Freedman, S. D.; Alexander, V. J.; Digenio, A.; Williams, K. R.; Yang, Q.; Hughes, S. G.; Geary, R. S.; Arca, M.; Stroes, E. S. G.; Bergeron, J.; Soran, H.; Civeira, F.; Hemphill, L.; Tsimikas, S.; Blom, D. J.; O'Dea, L.; Bruckert, E., Volanesorsen and Triglyceride Levels in Familial Chylomicronemia Syndrome. *N Engl J Med* **2019**, *381*, (6), 531-542.
94. Ramms, B.; Patel, S.; Nora, C.; Pessentheiner, A. R.; Chang, M. W.; Green, C. R.; Golden, G. J.; Secrest, P.; Krauss, R. M.; Metallo, C. M.; Benner, C.; Alexander, V. J.; Witztum, J. L.; Tsimikas, S.; Esko, J. D.; Gordts, P., ApoC-III ASO promotes tissue LPL activity in the absence of apoE-mediated TRL clearance. *J Lipid Res* **2019**, *60*, (8), 1379-1395.
95. Tsimikas, S.; Karwowska-Prokopczuk, E.; Gouni-Berthold, I.; Tardif, J. C.; Baum, S. J.; Steinhagen-Thiessen, E.; Shapiro, M. D.; Stroes, E. S.; Moriarty, P. M.; Nordestgaard, B. G.; Xia, S.; Guerriero, J.; Viney, N. J.; O'Dea, L.; Witztum, J. L.; Investigators, A. K.-A.-L. S., Lipoprotein(a) Reduction in Persons with Cardiovascular Disease. *N Engl J Med* **2020**, *382*, (3), 244-255.
96. Viney, N. J.; van Capelleveen, J. C.; Geary, R. S.; Xia, S.; Tami, J. A.; Yu, R. Z.; Marcovina, S. M.; Hughes, S. G.; Graham, M. J.; Crooke, R. M.; Crooke, S. T.; Witztum, J. L.; Stroes, E. S.; Tsimikas, S., Antisense oligonucleotides targeting apolipoprotein(a) in people with raised lipoprotein(a): two randomised, double-blind, placebo-controlled, dose-ranging trials. *Lancet* **2016**, *388*, (10057), 2239-2253.
97. Tsimikas, S.; Viney, N. J.; Hughes, S. G.; Singleton, W.; Graham, M. J.; Baker, B. F.; Burkey, J. L.; Yang, Q.; Marcovina, S. M.; Geary, R. S.; Crooke, R. M.; Witztum, J. L., Antisense therapy targeting apolipoprotein(a): a randomised, double-blind, placebo-controlled phase 1 study. *Lancet* **2015**, *386*, (10002), 1472-83.
98. Alfano, L. N.; Charleston, J. S.; Connolly, A. M.; Cripe, L.; Donoghue, C.; Dracker, R.; Dworzak, J.; Eliopoulos, H.; Frank, D. E.; Lewis, S.; Lucas, K.; Lynch, J.; Milici, A. J.; Flynt, A.; Naughton, E.; Rodino-Klapac, L. R.; Sahenk, Z.; Schnell, F. J.; Young, G. D.; Mendell, J. R.; Lowes, L. P., Long-term treatment with eteplirsen in nonambulatory patients with Duchenne muscular dystrophy. *Medicine (Baltimore)* **2019**, *98*, (26), e15858.
99. Minamisawa, M.; Claggett, B.; Adams, D.; Kristen, A. V.; Merlini, G.; Slama, M. S.; Dispenzieri, A.; Shah, A. M.; Falk, R. H.; Karsten, V.; Sweetser, M. T.; Chen, J.; Riese, R.; Vest, J.; Solomon, S. D., Association of Patisiran, an RNA Interference Therapeutic, With Regional Left Ventricular Myocardial Strain in Hereditary Transthyretin Amyloidosis: The APOLLO Study. *JAMA Cardiol* **2019**, *4*, (5), 466-472.
100. Ray, K. K.; Nicholls, S. J.; Buhr, K. A.; Ginsberg, H. N.; Johansson, J. O.; Kalantar-Zadeh, K.; Kulikowski, E.; Toth, P. P.; Wong, N.; Sweeney, M.; Schwartz, G. G.; Investigators, B. E.; Committees, Effect of Apabetalone Added to Standard Therapy on Major Adverse Cardiovascular Events in Patients With Recent Acute Coronary Syndrome and Type 2 Diabetes: A Randomized Clinical Trial. *JAMA* **2020**, *323*, (16), 1565-1573.
101. Elman, L.; Youn, B.; Proud, C. M.; Frey, M. R.; Ajroud-Driss, S.; McCormick, M. E.; Michelson, D.; Cartwright, M. S.; Heiman-Patterson, T.; Choi, J. M.; Chandak, A.; Khachatryan, A.; Martinez, M.; Paradis, A. D., Real-world Adherence to Nusinersen in Adults with Spinal Muscular Atrophy in the US: A Multi-site Chart Review Study. *J Neuromuscul Dis* **2022**.
102. Qiu, J.; Wu, L.; Qu, R.; Jiang, T.; Bai, J.; Sheng, L.; Feng, P.; Sun, J., History of development of the life-saving drug "Nusinersen" in spinal muscular atrophy. *Front Cell Neurosci* **2022**, *16*, 942976.
103. Adams, D.; Gonzalez-Duarte, A.; O'Riordan, W. D.; Yang, C. C.; Ueda, M.; Kristen, A. V.; Tournev, I.; Schmidt, H. H.; Coelho, T.; Berk, J. L.; Lin, K. P.; Vita, G.; Attarian, S.; Plante-Bordeneuve, V.; Mezei, M. M.; Campistol, J. M.; Buades, J.; Brannagan, T. H., 3rd; Kim, B. J.; Oh, J.; Parman, Y.; Sekijima, Y.; Hawkins, P. N.; Solomon, S. D.; Polydefkis, M.; Dyck, P. J.; Gandhi, P. J.; Goyal, S.; Chen, J.; Strahs, A. L.; Nochur, S. V.; Sweetser, M. T.; Garg, P. P.; Vaishnav, A. K.; Gollob, J. A.; Suhr, O. B., Patisiran, an RNAi Therapeutic, for Hereditary Transthyretin Amyloidosis. *N Engl J Med* **2018**, *379*, (1), 11-21.
104. Solomon, S. D.; Adams, D.; Kristen, A.; Grogan, M.; Gonzalez-Duarte, A.; Maurer, M. S.; Merlini, G.; Damy, T.; Slama, M. S.; Brannagan, T. H., 3rd; Dispenzieri, A.; Berk, J. L.; Shah, A. M.; Garg, P.; Vaishnav, A.; Karsten, V.; Chen, J.; Gollob, J.; Vest, J.; Suhr, O., Effects of Patisiran, an RNA Interference Therapeutic, on Cardiac Parameters in Patients With Hereditary Transthyretin-Mediated Amyloidosis. *Circulation* **2019**, *139*, (4), 431-443.
105. Levin, A. A., Treating Disease at the RNA Level with Oligonucleotides. *N Engl J Med* **2019**, *380*, (1), 57-70.

106. Taubel, J.; Hauke, W.; Rump, S.; Viereck, J.; Batkai, S.; Poetzsch, J.; Rode, L.; Weigt, H.; Genschel, C.; Lorch, U.; Theek, C.; Levin, A. A.; Bauersachs, J.; Solomon, S. D.; Thum, T., Novel antisense therapy targeting microRNA-132 in patients with heart failure: results of a first-in-human Phase 1b randomized, double-blind, placebo-controlled study. *Eur Heart J* **2021**, *42*, (2), 178-188.
107. Lassner, D.; Kuhl, U.; Siegismund, C. S.; Rohde, M.; Elezskurtaj, S.; Escher, F.; Tschöpe, C.; Gross, U. M.; Poller, W.; Schultheiss, H. P., Improved diagnosis of idiopathic giant cell myocarditis and cardiac sarcoidosis by myocardial gene expression profiling. *Eur Heart J* **2014**, *35*, (32), 2186-95.
108. Kuehl, U.; Lassner, D.; Gast, M.; Stroux, A.; Rohde, M.; Siegismund, C.; Wang, X.; Escher, F.; Gross, M.; Skurk, C.; Tschöpe, C.; Loebel, M.; Scheibenbogen, C.; Schultheiss, H. P.; Poller, W., Differential Cardiac MicroRNA Expression Predicts the Clinical Course in Human Enterovirus Cardiomyopathy. *Circ Heart Fail* **2015**, *8*, (3), 605-18.
109. Kasner, M.; Gast, M.; Galuszka, O.; Stroux, A.; Rutschow, S.; Wang, X.; Dohmen, P.; Skurk, C.; Landmesser, U.; Poller, W.; Gross, M., Circulating exosomal microRNAs predict functional recovery after MitraClip repair of severe mitral regurgitation. *Int J Cardiol* **2016**, *215*, 402-5.
110. Das, S.; Shah, R.; Dimmeler, S.; Freedman, J. E.; Holley, C.; Lee, J. M.; Moore, K.; Musunuru, K.; Wang, D. Z.; Xiao, J.; Yin, K. J.; American Heart Association Council on, G.; Precision, M.; Council on Arteriosclerosis, T.; Vascular, B.; Council on, C.; Stroke, N.; Council on Clinical, C., Noncoding RNAs in Cardiovascular Disease: Current Knowledge, Tools and Technologies for Investigation, and Future Directions: A Scientific Statement From the American Heart Association. *Circ Genom Precis Med* **2020**, *13*, (4), e000062.
111. Bar, C.; Chatterjee, S.; Falcao Pires, I.; Rodrigues, P.; Sluijter, J. P. G.; Boon, R. A.; Nevado, R. M.; Andres, V.; Sansonetti, M.; de Windt, L.; Ciccarelli, M.; Hamdani, N.; Heymans, S.; Figuinha Videira, R.; Tocchetti, C. G.; Giacca, M.; Zacchigna, S.; Engelhardt, S.; Dimmeler, S.; Madonna, R.; Thum, T., Non-coding RNAs: update on mechanisms and therapeutic targets from the ESC Working Groups of Myocardial Function and Cellular Biology of the Heart. *Cardiovasc Res* **2020**, *116*, (11), 1805-1819.
112. Dias, T. R.; Dias, F.; Teixeira, A. L.; Sousa, H.; Oliveira, J.; Medeiros, R., MicroRNAs as Potential Tools for Predicting Cancer Patients' Susceptibility to SARS-CoV-2 Infection and Vaccination Response. *Cells* **2022**, *11*, (15).
113. Marcia, M., The multiple molecular dimensions of long noncoding RNAs that regulate gene expression and tumorigenesis. *Curr Opin Oncol* **2022**, *34*, (2), 141-147.
114. Filippakopoulos, P.; Qi, J.; Picaud, S.; Shen, Y.; Smith, W. B.; Fedorov, O.; Morse, E. M.; Keates, T.; Hickman, T. T.; Felletar, I.; Philpott, M.; Munro, S.; McKeown, M. R.; Wang, Y.; Christie, A. L.; West, N.; Cameron, M. J.; Schwartz, B.; Heightman, T. D.; La Thangue, N.; French, C. A.; Wiest, O.; Kung, A. L.; Knapp, S.; Bradner, J. E., Selective inhibition of BET bromodomains. *Nature* **2010**, *468*, (7327), 1067-73.
115. Filippakopoulos, P.; Knapp, S., Targeting bromodomains: epigenetic readers of lysine acetylation. *Nat Rev Drug Discov* **2014**, *13*, (5), 337-56.
116. Ciceri, P.; Müller, S.; O'Mahony, A.; Fedorov, O.; Filippakopoulos, P.; Hunt, J. P.; Lasater, E. A.; Pallares, G.; Picaud, S.; Wells, C.; Martin, S.; Wodicka, L. M.; Shah, N. P.; Treiber, D. K.; Knapp, S., Dual kinase-bromodomain inhibitors for rationally designed polypharmacology. *Nature Chemical Biology* **2014**, *10*, 305.
117. Nicholls, S. J.; Ray, K. K.; Johansson, J. O.; Gordon, A.; Sweeney, M.; Halliday, C.; Kulikowski, E.; Wong, N.; Kim, S. W.; Schwartz, G. G., Selective BET Protein Inhibition with Apabetalone and Cardiovascular Events: A Pooled Analysis of Trials in Patients with Coronary Artery Disease. *Am J Cardiovasc Drugs* **2018**, *18*, (2), 109-115.
118. Tsujikawa, L. M.; Fu, L.; Das, S.; Halliday, C.; Rakai, B. D.; Stotz, S. C.; Sarsons, C. D.; Gilham, D.; Daze, E.; Wasiak, S.; Studer, D.; Rinker, K. D.; Sweeney, M.; Johansson, J. O.; Wong, N. C. W.; Kulikowski, E., Apabetalone (RVX-208) reduces vascular inflammation in vitro and in CVD patients by a BET-dependent epigenetic mechanism. *Clin Epigenetics* **2019**, *11*, (1), 102.
119. Kulikowski, E.; Halliday, C.; Johansson, J.; Sweeney, M.; Lebioda, K.; Wong, N.; Haarhaus, M.; Brandenburg, V.; Beddhu, S.; Tonelli, M.; Zoccali, C.; Kalantar-Zadeh, K., Apabetalone Mediated Epigenetic Modulation is Associated with Favorable Kidney Function and Alkaline Phosphatase Profile in Patients with Chronic Kidney Disease. *Kidney Blood Press Res* **2018**, *43*, (2), 449-457.
120. Shishikura, D.; Kataoka, Y.; Honda, S.; Takata, K.; Kim, S. W.; Andrews, J.; Psaltis, P. J.; Sweeney, M.; Kulikowski, E.; Johansson, J.; Wong, N. C. W.; Nicholls, S. J., The Effect of Bromodomain and Extra-Terminal Inhibitor Apabetalone on Attenuated Coronary Atherosclerotic Plaque: Insights from the ASSURE Trial. *Am J Cardiovasc Drugs* **2019**, *19*, (1), 49-57.
121. Gast, M.; Rauch, B. H.; Nakagawa, S.; Haghikia, A.; Jasina, A.; Haas, J.; Nath, N.; Jensen, L.; Stroux, A.; Böhm, A.; Friebel, J.; Rauch, U.; Skurk, C.; Blankenberg, S.; Zeller, T.; Prasanth, K. V.; Meder, B.; Kuss, A.; Landmesser, U.; Poller, W., Immune system-mediated atherosclerosis caused by deficiency of long non-coding RNA MALAT1 in ApoE<sup>-/-</sup> mice. *Cardiovasc Res* **2019**, *115*, (2), 302-314.
122. Gast, M.; Rauch, B. H.; Haghikia, A.; Nakagawa, S.; Haas, J.; Stroux, A.; Schmidt, D.; Schumann, P.; Weiss, S.; Jensen, L.; Kratzer, A.; Kraenkel, N.; Müller, C.; Bornigen, D.; Hirose, T.; Blankenberg, S.; Escher, F.; Kuhl, A. A.; Kuss, A. W.; Meder, B.; Landmesser, U.; Zeller, T.; Poller, W., Long noncoding RNA NEAT1 modulates immune cell functions and is suppressed in early onset myocardial infarction patients. *Cardiovasc Res* **2019**, *115*, (13), 1886-1906.

123. Cremer, S.; Michalik, K. M.; Fischer, A.; Pfisterer, L.; Jae, N.; Winter, C.; Boon, R. A.; Muhly-Reinholz, M.; John, D.; Uchida, S.; Weber, C.; Poller, W.; Gunther, S.; Braun, T.; Li, D. Y.; Maegdefessel, L.; Perisic Matic, L.; Hedin, U.; Soehnlein, O.; Zeiher, A.; Dimmeler, S., Hematopoietic Deficiency of the Long Noncoding RNA MALAT1 Promotes Atherosclerosis and Plaque Inflammation. *Circulation* **2019**, 139, (10), 1320-1334.
124. Gast, M.; Schroen, B.; Voigt, A.; Haas, J.; Kuehl, U.; Lassner, D.; Skurk, C.; Escher, F.; Wang, X.; Kratzer, A.; Michalik, K.; Papanageorgiou, A.; Peters, T.; Loebel, M.; Wilk, S.; Althof, N.; Prasanth, K. V.; Katus, H.; Meder, B.; Nakagawa, S.; Scheibenbogen, C.; Schultheiss, H. P.; Landmesser, U.; Dimmeler, S.; Heymans, S.; Poller, W., Long noncoding RNA MALAT1-derived mas-cRNA is involved in cardiovascular innate immunity. *J Mol Cell Biol* **2016**, 8, (2), 178-81.
125. Gast, M.; Nageswaran, V.; Kuss, A. W.; Tzvetkova, A.; Wang, X.; Mochmann, L. H.; Ramezani Rad, P.; Weiss, S.; Simm, S.; Zeller, T.; Voelzke, H.; Hoffmann, W.; Völker, U.; Felix, S. B.; Dörr, M.; Beling, A.; Skurk, C.; Leistner, D.-M.; Rauch, B. H.; Hirose, T.; Heidecker, B.; Klingel, K.; Nakagawa, S.; Poller, W. C.; Swirski, F. K.; Haghikia, A.; Poller, W., Novel tRNA-like transcripts from the NEAT1-MALAT1 genomic region critically influence human innate immunity and macrophage functions. *Research Square Preprint* **2022**.
126. Mocchi, S.; Littera, R.; Tranquilli, S.; Provenzano, A.; Mascia, A.; Cannas, F.; Lai, S.; Giuressi, E.; Chessa, L.; Angioni, G.; Campagna, M.; Firinu, D.; Del Zompo, M.; La Nasa, G.; Perra, A.; Giglio, S., A Protective HLA Extended Haplotype Outweighs the Major COVID-19 Risk Factor Inherited From Neanderthals in the Sardinian Population. *Front Immunol* **2022**, 13, 891147.
127. Le, M. K.; Smith, O. S.; Akbari, A.; Harpak, A.; Reich, D.; Narasimhan, V. M., 1,000 ancient genomes uncover 10,000 years of natural selection in Europe. *bioRxiv* **2022**.
128. Chan, F. H. M.; Ataide, R.; Richards, J. S.; Narh, C. A., Contrasting Epidemiology and Population Genetics of COVID-19 Infections Defined by Multilocus Genotypes in SARS-CoV-2 Genomes Sampled Globally. *Viruses* **2022**, 14, (7).
129. The Human Pangenome. <https://youtu.be/swNtGe9QWAQ>
130. Human Epigenome Consortium. <https://www.epigenome.org/>
131. WashU Epigenome Browser. <https://epigenomegateway.wustl.edu/browser/>
132. The complete sequence of a human genome. <https://www.science.org/doi/epdf/10.1126/science.abj6987>
133. The structure, function and evolution of a complete human chromosome 8. <https://www.nature.com/articles/s41586-021-03420-7>
134. Telomere-to-telomere assembly of a complete human X chromosome. <https://www.nature.com/articles/s41586-020-2547-7>
135. Segmental duplications and their variation in a complete human genome. <https://www.science.org/doi/10.1126/science.abj6965>
136. Epigenetic patterns in a complete human genome. <https://www.science.org/doi/10.1126/science.abj5089>
137. A complete reference genome improves analysis of human genetic variation. <https://www.science.org/doi/10.1126/science.abl3533>
138. From telomere to telomere: The transcriptional and epigenetic state of human repeat elements. <https://www.science.org/doi/10.1126/science.abk3112>
139. Complete genomic and epigenetic maps of human centromeres. <https://www.science.org/doi/10.1126/science.abl4178>
140. A next-generation human genome sequence. <https://www.science.org/doi/10.1126/science.abo5367>
141. Li, D.; Purushotham, D.; Harrison, J. K.; Hsu, S.; Zhuo, X.; Fan, C.; Liu, S.; Xu, V.; Chen, S.; Xu, J.; Ouyang, S.; Wu, A. S.; Wang, T., WashU Epigenome Browser update 2022. *Nucleic Acids Res* **2022**.
142. Ma, X.; Cheng, S.; Ding, R.; Zhao, Z.; Zou, X.; Guang, S.; Wang, Q.; Jing, H.; Yu, C.; Ni, T.; Li, L., ipaQTL-atlas: an atlas of intronic polyadenylation quantitative trait loci across human tissues. *Nucleic Acids Res* **2022**.
143. Harrison, L. J.; Bose, D., Enhancer RNAs step forward: new insights into enhancer function. *Development* **2022**, 149, (16).
144. Somasundaram, K.; Gupta, B.; Jain, N.; Jana, S., LncRNAs divide and rule: The master regulators of phase separation. *Front Genet* **2022**, 13, 930792.
145. Busscher, D.; Boon, R. A.; Juni, R. P., The multifaceted actions of the lncRNA H19 in cardiovascular biology and diseases. *Clin Sci (Lond)* **2022**, 136, (15), 1157-1178.
146. Shi, Y.; Zhang, H.; Huang, S.; Yin, L.; Wang, F.; Luo, P.; Huang, H., Epigenetic regulation in cardiovascular disease: mechanisms and advances in clinical trials. *Signal Transduct Target Ther* **2022**, 7, (1), 200.
147. Ntarelli, L.; Weber, C., A Non-Canonical Link between Non-Coding RNAs and Cardiovascular Diseases. *Biomedicines* **2022**, 10, (2).
148. Nukala, S. B.; Jousma, J.; Cho, Y.; Lee, W. H.; Ong, S. G., Long non-coding RNAs and microRNAs as crucial regulators in cardiovascular oncology. *Cell Biosci* **2022**, 12, (1), 24.
149. Anderson, K. M.; Anderson, D. M., LncRNAs at the heart of development and disease. *Mamm Genome* **2022**, 33, (2), 354-365.
150. Chen, Z.; Natarajan, R., Epigenetic modifications in metabolic memory: What are the memories, and can we erase them? *Am J Physiol Cell Physiol* **2022**, 323, (2), C570-C582.

151. Bavineni, M.; Wassenaar, T. M.; Agnihotri, K.; Ussery, D. W.; Luscher, T. F.; Mehta, J. L., Mechanisms linking preterm birth to onset of cardiovascular disease later in adulthood. *Eur Heart J* **2019**, *40*, (14), 1107-1112.
152. Al-Hasani, K.; Mathiyalagan, P.; El-Osta, A., Epigenetics, cardiovascular disease, and cellular reprogramming. *J Mol Cell Cardiol* **2019**, *128*, 129-133.
153. Ward-Caviness, C. K.; Agha, G.; Chen, B. H.; Pfeiffer, L.; Wilson, R.; Wolf, P.; Gieger, C.; Schwartz, J.; Vokonas, P. S.; Hou, L.; Just, A. C.; Bandinelli, S.; Hernandez, D. G.; Singleton, A. B.; Prokisch, H.; Meitinger, T.; Kastenmuller, G.; Ferrucci, L.; Baccarelli, A. A.; Waldenberger, M.; Peters, A., Analysis of repeated leukocyte DNA methylation assessments reveals persistent epigenetic alterations after an incident myocardial infarction. *Clin Epigenetics* **2018**, *10*, (1), 161.
154. Pagiatakis, C.; Condorelli, G., The RNA Methylome Blackboard. *Circulation* **2019**, *139*, (4), 546-548.
155. Gorica, E.; Mohammed, S. A.; Ambrosini, S.; Calderone, V.; Costantino, S.; Paneni, F., Epi-Drugs in Heart Failure. *Front Cardiovasc Med* **2022**, *9*, 923014.
156. Del Castillo Falconi, V. M.; Torres-Arciga, K.; Matus-Ortega, G.; Diaz-Chavez, J.; Herrera, L. A., DNA Methyltransferases: From Evolution to Clinical Applications. *Int J Mol Sci* **2022**, *23*, (16).
157. Schultheiss, H. P.; Baumeier, C.; Pietsch, H.; Bock, C. T.; Poller, W.; Escher, F., Cardiovascular consequences of viral infections: from COVID to other viral diseases. *Cardiovasc Res* **2021**, *117*, (13), 2610-2623.
158. Fechner, H.; Pinkert, S.; Geisler, A.; Poller, W.; Kurreck, J., Pharmacological and biological antiviral therapeutics for cardiac coxsackievirus infections. *Molecules* **2011**, *16*, (10), 8475-503.
159. Schultheiss, H.-P.; Bock, C.-T.; Aleshcheva, G.; Baumeier, C.; Poller, W.; Escher, F., Interferon- $\beta$  Suppresses Transcriptionally Active Parvovirus B19 Infection in Viral Cardiomyopathy: A Subgroup Analysis of the BICC-Trial. *Viruses* **2022**.
160. Escher, F.; Kuhl, U.; Gross, U.; Westermann, D.; Poller, W.; Tschöpe, C.; Lassner, D.; Schultheiss, H. P., Aggravation of left ventricular dysfunction in patients with biopsy-proven cardiac human herpesvirus A and B infection. *J Clin Virol* **2015**, *63*, 1-5.
161. Kuhl, U.; Lassner, D.; Wallaschek, N.; Gross, U. M.; Krueger, G. R.; Seeberg, B.; Kaufer, B. B.; Escher, F.; Poller, W.; Schultheiss, H. P., Chromosomally integrated human herpesvirus 6 in heart failure: prevalence and treatment. *Eur J Heart Fail* **2015**, *17*, (1), 9-19.
162. Poller, W.; Kaya, Z.; Mücke, M.; Kasner, M.; Skurk, C.; Kappert, K.; Tauber, R.; Escher, F.; Schultheiss, H. P.; Epple, H. J.; Landmesser, U., High incidence of cardiac dysfunction and response to antiviral treatment in patients with chronic hepatitis C virus infection. *Clin Res Cardiol* **2017**, *106*, (7), 551-556.
163. Poller, W.; Haghikia, A.; Kasner, M.; Kaya, Z.; Bavendiek, U.; Wedemeier, H.; Epple, H. J.; Skurk, C.; Landmesser, U., Cardiovascular Involvement in Chronic Hepatitis C Virus Infections - Insight from Novel Antiviral Therapies. *J Clin Transl Hepatol* **2018**, *6*, (2), 161-167.
164. Almamlouk, R.; Kashour, T.; Obeidat, S.; Bois, M. C.; Maleszewski, J. J.; Omrani, O. A.; Tleyjeh, R.; Berbari, E.; Chakhachiro, Z.; Zein-Sabatto, B.; Gerberi, D.; Tleyjeh, I. M.; Cardiac Autopsy in, C.-S. G., COVID-19-associated cardiac pathology at post-mortem evaluation: A Collaborative systematic Review. *Clin Microbiol Infect* **2022**.
165. Brauningner, H.; Stoffers, B.; Fitzek, A. D. E.; Meissner, K.; Aleshcheva, G.; Schweizer, M.; Weimann, J.; Rotter, B.; Warnke, S.; Edler, C.; Braun, F.; Roedl, K.; Scherschel, K.; Escher, F.; Kluge, S.; Huber, T. B.; Ondruschka, B.; Schultheiss, H. P.; Kirchhof, P.; Blankenberg, S.; Puschel, K.; Westermann, D.; Lindner, D., Cardiac SARS-CoV-2 infection is associated with pro-inflammatory transcriptomic alterations within the heart. *Cardiovasc Res* **2022**, *118*, (2), 542-555.
166. Lindner, D.; Fitzek, A.; Brauningner, H.; Aleshcheva, G.; Edler, C.; Meissner, K.; Scherschel, K.; Kirchhof, P.; Escher, F.; Schultheiss, H. P.; Blankenberg, S.; Puschel, K.; Westermann, D., Association of Cardiac Infection With SARS-CoV-2 in Confirmed COVID-19 Autopsy Cases. *JAMA Cardiol* **2020**, *5*, (11), 1281-1285.
167. Nicin, L.; Abplanalp, W. T.; Mellentin, H.; Kattih, B.; Tombor, L.; John, D.; Schmitto, J. D.; Heineke, J.; Emrich, F.; Arsalan, M.; Holubec, T.; Walther, T.; Zeiher, A. M.; Dimmeler, S., Cell type-specific expression of the putative SARS-CoV-2 receptor ACE2 in human hearts. *Eur Heart J* **2020**, *41*, (19), 1804-1806.
168. Bailey, A. L.; Dmytrenko, O.; Greenberg, L.; Bredemeyer, A. L.; Ma, P.; Liu, J.; Penna, V.; Winkler, E. S.; Sviben, S.; Brooks, E.; Nair, A. P.; Heck, K. A.; Rali, A. S.; Simpson, L.; Saririan, M.; Hobohm, D.; Stump, W. T.; Fitzpatrick, J. A.; Xie, X.; Zhang, X.; Shi, P. Y.; Hinson, J. T.; Gi, W. T.; Schmidt, C.; Leuschner, F.; Lin, C. Y.; Diamond, M. S.; Greenberg, M. J.; Lavine, K. J., SARS-CoV-2 Infects Human Engineered Heart Tissues and Models COVID-19 Myocarditis. *JACC Basic Transl Sci* **2021**, *6*, (4), 331-345.
169. Guzik, T. J.; Mohiddin, S. A.; Dimarco, A.; Patel, V.; Savvatis, K.; Marelli-Berg, F. M.; Madhur, M. S.; Tomaszewski, M.; Maffia, P.; D'Acquisto, F.; Nicklin, S. A.; Marian, A. J.; Nosalski, R.; Murray, E. C.; Guzik, B.; Berry, C.; Touyz, R. M.; Kreutz, R.; Wang, D. W.; Bhella, D.; Sagliocco, O.; Crea, F.; Thomson, E. C.; McInnes, I. B., COVID-19 and the cardiovascular system: implications for risk assessment, diagnosis, and treatment options. *Cardiovasc Res* **2020**, *116*, (10), 1666-1687.
170. Abbott, T. R.; Dhamdhare, G.; Liu, Y.; Lin, X.; Goudy, L.; Zeng, L.; Chemparathy, A.; Chmura, S.; Heaton, N. S.; Debs, R.; Pande, T.; Endy, D.; La Russa, M. F.; Lewis, D. B.; Qi, L. S., Development of CRISPR as an Antiviral Strategy to Combat SARS-CoV-2 and Influenza. *Cell* **2020**, *181*, (4), 865-876 e12.

171. Idris, A.; Davis, A.; Supramaniam, A.; Acharya, D.; Kelly, G.; Tayyar, Y.; West, N.; Zhang, P.; McMillan, C. L. D.; Soemardy, C.; Ray, R.; O'Meally, D.; Scott, T. A.; McMillan, N. A. J.; Morris, K. V., A SARS-CoV-2 targeted siRNA-nanoparticle therapy for COVID-19. *Mol Ther* **2021**, *29*, (7), 2219-2226.
172. Sajid, M. I.; Moazzam, M.; Cho, Y.; Kato, S.; Xu, A.; Way, J. J.; Lohan, S.; Tiwari, R. K., siRNA Therapeutics for the Therapy of COVID-19 and Other Coronaviruses. *Mol Pharm* **2021**, *18*, (6), 2105-2121.
173. Baldassarre, A.; Paolini, A.; Bruno, S. P.; Felli, C.; Tozzi, A. E.; Masotti, A., Potential use of noncoding RNAs and innovative therapeutic strategies to target the 5'UTR of SARS-CoV-2. *Epigenomics* **2020**, *12*, (15), 1349-1361.
174. Sun, L.; Li, P.; Ju, X.; Rao, J.; Huang, W.; Ren, L.; Zhang, S.; Xiong, T.; Xu, K.; Zhou, X.; Gong, M.; Miska, E.; Ding, Q.; Wang, J.; Zhang, Q. C., In vivo structural characterization of the SARS-CoV-2 RNA genome identifies host proteins vulnerable to repurposed drugs. *Cell* **2021**, *184*, (7), 1865-1883 e20.
175. DeGrace, M. M.; Ghedin, E.; Frieman, M. B.; Krammer, F.; Grifoni, A.; Alisoltani, A.; Alter, G.; Amara, R. R.; Baric, R. S.; Barouch, D. H.; Bloom, J. D.; Bloyet, L. M.; Bonenfant, G.; Boon, A. C. M.; Boritz, E. A.; Bratt, D. L.; Bricker, T. L.; Brown, L.; Buchser, W. J.; Carreno, J. M.; Cohen-Lavi, L.; Darling, T. L.; Davis-Gardner, M. E.; Dearlove, B. L.; Di, H.; Dittmann, M.; Doria-Rose, N. A.; Douek, D. C.; Drosten, C.; Edara, V. V.; Ellebedy, A.; Fabrizio, T. P.; Ferrari, G.; Fischer, W. M.; Florence, W. C.; Fouchier, R. A. M.; Franks, J.; Garcia-Sastre, A.; Godzik, A.; Gonzalez-Reiche, A. S.; Gordon, A.; Haagmans, B. L.; Halfmann, P. J.; Ho, D. D.; Holbrook, M. R.; Huang, Y.; James, S. L.; Jaroszewski, L.; Jeevan, T.; Johnson, R. M.; Jones, T. C.; Joshi, A.; Kawaoka, Y.; Kercher, L.; Koopmans, M. P. G.; Korber, B.; Koren, E.; Koup, R. A.; LeGresley, E. B.; Lemieux, J. E.; Liebeskind, M. J.; Liu, Z.; Livingston, B.; Logue, J. P.; Luo, Y.; McDermott, A. B.; McElrath, M. J.; Meliopoulos, V. A.; Menachery, V. D.; Montefiori, D. C.; Muhlemann, B.; Munster, V. J.; Munt, J. E.; Nair, M. S.; Netzl, A.; Niewiadomska, A. M.; O'Dell, S.; Pekosz, A.; Perlman, S.; Pontelli, M. C.; Rockx, B.; Rolland, M.; Rothlauf, P. W.; Sacharen, S.; Scheuermann, R. H.; Schmidt, S. D.; Schotsaert, M.; Schultz-Cherry, S.; Seder, R. A.; Sedova, M.; Sette, A.; Shabman, R. S.; Shen, X.; Shi, P. Y.; Shukla, M.; Simon, V.; Stumpf, S.; Sullivan, N. J.; Thackray, L. B.; Theiler, J.; Thomas, P. G.; Trifkovic, S.; Tureli, S.; Turner, S. A.; Vakaki, M. A.; van Bakel, H.; VanBlargan, L. A.; Vincent, L. R.; Wallace, Z. S.; Wang, L.; Wang, M.; Wang, P.; Wang, W.; Weaver, S. C.; Webby, R. J.; Weiss, C. D.; Wentworth, D. E.; Weston, S. M.; Whelan, S. P. J.; Whitener, B. M.; Wilks, S. H.; Xie, X.; Ying, B.; Yoon, H.; Zhou, B.; Hertz, T.; Smith, D. J.; Diamond, M. S.; Post, D. J.; Suthar, M. S., Defining the risk of SARS-CoV-2 variants on immune protection. *Nature* **2022**, *605*, (7911), 640-652.
176. Li, N.; Rana, T. M., Regulation of antiviral innate immunity by chemical modification of viral RNA. *Wiley Interdiscip Rev RNA* **2022**, e1720.
177. Kudriavtsev, A. V.; Vakhrusheva, A. V.; Novosmalle, C. V. N.; Bozdaganyan, M. E.; Shaitan, K. V.; Kirpichnikov, M. P.; Sokolova, O. S., Immune Escape Associated with RBD Omicron Mutations and SARS-CoV-2 Evolution Dynamics. *Viruses* **2022**, *14*, (8).
178. Hammer, Q.; Dunst, J.; Christ, W.; Picarazzi, F.; Wendorff, M.; Momayyezi, P.; Huhn, O.; Netskar, H. K.; Maleki, K. T.; Garcia, M.; Sekine, T.; Sohlberg, E.; Azzimato, V.; Aouadi, M.; Karolinska, C.-S. G.; Severe, C.-G. G.; Degenhardt, F.; Franke, A.; Spallotta, F.; Mori, M.; Michaelsson, J.; Bjorkstrom, N. K.; Ruckert, T.; Romagnani, C.; Horowitz, A.; Klingstrom, J.; Ljunggren, H. G.; Malmberg, K. J., SARS-CoV-2 Nsp13 encodes for an HLA-E-stabilizing peptide that abrogates inhibition of NKG2A-expressing NK cells. *Cell Rep* **2022**, *38*, (10), 110503.
179. Heidecker, B.; Williams, S. H.; Jain, K.; Olynyk, A.; Patriki, D.; Kottwitz, J.; Berg, J.; Garcia, J. A.; Baltensperger, N.; Lovrinovic, M.; Baltensweiler, A.; Mishra, N.; Briese, T.; Hanson, P. J.; Lauten, A.; Poller, W.; Leistner, D. M.; Landmesser, U.; Enseleit, F.; McManus, B.; Luscher, T. F.; Lipkin, W. I., Virome Sequencing in Patients With Myocarditis. *Circ Heart Fail* **2020**, *13*, (7), e007103.
180. Veronese, G.; Ammirati, E.; Brambatti, M.; Merlo, M.; Cipriani, M.; Potena, L.; Sormani, P.; Aoki, T.; Sugimura, K.; Sawamura, A.; Okumura, T.; Pinney, S.; Hong, K.; Shah, P.; Braun, O. O.; Van de Heyning, C. M.; Montero, S.; Petrella, D.; Huang, F.; Schmidt, M.; Raineri, C.; Lala, A.; Varrenti, M.; Foa, A.; Leone, O.; Gentile, P.; Artico, J.; Agostini, V.; Patel, R.; Garascia, A.; Van Craenenbroeck, E. M.; Hirose, K.; Isotani, A.; Murohara, T.; Arita, Y.; Sionis, A.; Fabris, E.; Hashem, S.; Garcia-Hernando, V.; Oliva, F.; Greenberg, B.; Shimokawa, H.; Sinagra, G.; Adler, E. D.; Frigerio, M.; Camici, P. G., Viral genome search in myocardium of patients with fulminant myocarditis. *Eur J Heart Fail* **2020**, *22*, (7), 1277-1280.
181. The Global Virome in One Network (VIRION): an Atlas of Vertebrate-Virus Associations. <https://journals.asm.org/doi/10.1128/mbio.02985-21>
182. Carlson, C. J.; Gibb, R. J.; Albery, G. F.; Brierley, L.; Connor, R. P.; Dallas, T. A.; Eskew, E. A.; Fagre, A. C.; Farrell, M. J.; Frank, H. K.; Muylaert, R. L.; Poisot, T.; Rasmussen, A. L.; Ryan, S. J.; Seifert, S. N., The Global Virome in One Network (VIRION): an Atlas of Vertebrate-Virus Associations. *mBio* **2022**, *13*, (2), e0298521.
183. Why the ocean virome matters. <https://www.nature.com/articles/s41592-022-01567-3>
184. Morens, D. M.; Fauci, A. S., Emerging Pandemic Diseases: How We Got to COVID-19. *Cell* **2020**, *182*, (5), 1077-1092.
185. Zhou, P.; Yang, X. L.; Wang, X. G.; Hu, B.; Zhang, L.; Zhang, W.; Si, H. R.; Zhu, Y.; Li, B.; Huang, C. L.; Chen, H. D.; Chen, J.; Luo, Y.; Guo, H.; Jiang, R. D.; Liu, M. Q.; Chen, Y.; Shen, X. R.; Wang, X.; Zheng, X. S.; Zhao, K.; Chen, Q. J.; Deng, F.; Liu, L. L.; Yan, B.; Zhan, F. X.; Wang, Y. Y.; Xiao, G. F.; Shi, Z. L., A pneumonia outbreak associated with a new coronavirus of probable bat origin. *Nature* **2020**, *579*, (7798), 270-273.

186. Zhou, F.; Yu, T.; Du, R.; Fan, G.; Liu, Y.; Liu, Z.; Xiang, J.; Wang, Y.; Song, B.; Gu, X.; Guan, L.; Wei, Y.; Li, H.; Wu, X.; Xu, J.; Tu, S.; Zhang, Y.; Chen, H.; Cao, B., Clinical course and risk factors for mortality of adult inpatients with COVID-19 in Wuhan, China: a retrospective cohort study. *Lancet* **2020**, *395*, (10229), 1054-1062.
187. Latinne, A.; Hu, B.; Olival, K. J.; Zhu, G.; Zhang, L.; Li, H.; Chmura, A. A.; Field, H. E.; Zambrana-Torrel, C.; Epstein, J. H.; Li, B.; Zhang, W.; Wang, L. F.; Shi, Z. L.; Daszak, P., Origin and cross-species transmission of bat coronaviruses in China. *bioRxiv* **2020**.
188. Degenhardt, F.; Ellinghaus, D.; Juzenas, S.; Lerga-Jaso, J.; Wendorff, M.; Maya-Miles, D.; Uellendahl-Werth, F.; ElAbd, H.; Ruhlemann, M. C.; Arora, J.; Ozer, O.; Lenning, O. B.; Myhre, R.; Vadla, M. S.; Wacker, E. M.; Wienbrandt, L.; Ortiz, A. B.; Salazar, A.; Chercoles, A. G.; Palom, A.; Ruiz, A.; Garcia-Fernandez, A. E.; Blanco-Grau, A.; Mantovani, A.; Zanella, A.; Holten, A. R.; Mayer, A.; Bandera, A.; Cherubini, A.; Protti, A.; Aghemo, A.; Gerussi, A.; Ramirez, A.; Braun, A.; Nebel, A.; Barreira, A.; Lleo, A.; Teles, A.; Kildal, A. B.; Biondi, A.; Caballero-Garralda, A.; Ganna, A.; Gori, A.; Gluck, A.; Lind, A.; Tanck, A.; Hinney, A.; Nolla, A. C.; Fracanzani, A. L.; Peschuck, A.; Cavallero, A.; Dyrhol-Riise, A. M.; Ruello, A.; Julia, A.; Muscatello, A.; Pesenti, A.; Voza, A.; Rando-Segura, A.; Solier, A.; Schmidt, A.; Cortes, B.; Mateos, B.; Nafria-Jimenez, B.; Schaefer, B.; Jensen, B.; Bellinghausen, C.; Maj, C.; Ferrando, C.; Horra, C.; Quereda, C.; Skurk, C.; Thibeault, C.; Scollo, C.; Herr, C.; Spinner, C. D.; Gassner, C.; Lange, C.; Hu, C.; Paccapelo, C.; Lehmann, C.; Angelini, C.; Cappadona, C.; Azuure, C.; Covicat study group, A. S.; Bianco, C.; Cea, C.; Sancho, C.; Hoff, D. A. L.; Galimberti, D.; Prati, D.; Haschka, D.; Jimenez, D.; Pestana, D.; Toapanta, D.; Muniz-Diaz, E.; Azzolini, E.; Sandoval, E.; Binatti, E.; Scarpini, E.; Helbig, E. T.; Casalone, E.; Urrechaga, E.; Paraboschi, E. M.; Pontali, E.; Reverter, E.; Calderon, E. J.; Navas, E.; Solligard, E.; Contro, E.; Arana-Arri, E.; Aziz, F.; Garcia, F.; Sanchez, F. G.; Ceriotti, F.; Martinelli-Boneschi, F.; Peyvandi, F.; Kurth, F.; Blasi, F.; Malvestiti, F.; Medrano, F. J.; Mesonero, F.; Rodriguez-Frias, F.; Hanses, F.; Muller, F.; Hemmrich-Stanisak, G.; Bellani, G.; Grasselli, G.; Pezzoli, G.; Costantino, G.; Albano, G.; Cardamone, G.; Bellelli, G.; Citerio, G.; Foti, G.; Lamorte, G.; Matullo, G.; Baselli, G.; Kurihara, H.; Neb, H.; My, I.; Kurth, I.; Hernandez, I.; Pink, I.; Rojas, I.; Galvan-Femenia, I.; Holter, J. C.; Afset, J. E.; Heyckendorf, J.; Kassens, J.; Damas, J. K.; Rybniker, J.; Altmuller, J.; Ampuero, J.; Martin, J.; Erdmann, J.; Banales, J. M.; Badia, J. R.; Dopazo, J.; Schneider, J.; Bergan, J.; Barretina, J.; Walter, J.; Quero, J. H.; Goikoetxea, J.; Delgado, J.; Guerrero, J. M.; Fazaal, J.; Kraft, J.; Schroder, J.; Risnes, K.; Banasik, K.; Muller, K. E.; Gaede, K. I.; Garcia-Etxebarria, K.; Tonby, K.; Heggelund, L.; Izquierdo-Sanchez, L.; Bettini, L. R.; Sumoy, L.; Sander, L. E.; Lippert, L. J.; Terranova, L.; Nkam-bule, L.; Knopp, L.; Gustad, L. T.; Garbarino, L.; Santoro, L.; Tellez, L.; Roade, L.; Ostadrea, M.; Intxausti, M.; Kogevinas, M.; Riveiro-Barciela, M.; Berger, M. M.; Schaefer, M.; Niemi, M. E. K.; Gutierrez-Stampa, M. A.; Carrabba, M.; Figuera Basso, M. E.; Valsecchi, M. G.; Hernandez-Tejero, M.; Vehreschild, M.; Manunta, M.; Acosta-Herrera, M.; D'Angio, M.; Baldini, M.; Cazzaniga, M.; Grimsrud, M. M.; Cornberg, M.; Nothen, M. M.; Marquie, M.; Castoldi, M.; Cordioli, M.; Cecconi, M.; D'Amato, M.; Augustin, M.; Tomasi, M.; Boada, M.; Dreher, M.; Seilmaier, M. J.; Joannidis, M.; Wittig, M.; Mazzocco, M.; Ciccirelli, M.; Rodriguez-Gandia, M.; Boccione, M.; Miozzo, M.; Ayo, N. I.; Blay, N.; Chueca, N.; Montano, N.; Braun, N.; Ludwig, N.; Marx, N.; Martinez, N.; Norwegian, S.-C.-S. g.; Cornely, O. A.; Witzke, O.; Palmieri, O.; Pa Study, G.; Faverio, P.; Preatoni, P.; Bonfanti, P.; Omodei, P.; Tentorio, P.; Castro, P.; Rodrigues, P. M.; Espana, P. P.; Hoffmann, P.; Rosenstiel, P.; Schommers, P.; Suwalski, P.; Pablo, R.; Ferrer, R.; Bals, R.; Gualtierotti, R.; Gallego-Duran, R.; Nieto, R.; Carpani, R.; Morilla, R.; Badalamenti, S.; Haider, S.; Ciesek, S.; May, S.; Bombace, S.; Marsal, S.; Pigazzini, S.; Klein, S.; Pelusi, S.; Wilfling, S.; Bosari, S.; Volland, S.; Brunak, S.; Raychaudhuri, S.; Schreiber, S.; Heilmann-Heimbach, S.; Aliberti, S.; Ripke, S.; Dudman, S.; Wesse, T.; Zheng, T.; Storm Study group, T. H. T. F. T. H. G. T. F.; Bahmer, T.; Eggermann, T.; Illig, T.; Brenner, T.; Pumarola, T.; Feldt, T.; Folseraas, T.; Cejudo, T. G.; Landmesser, U.; Protzer, U.; Hehr, U.; Rimoldi, V.; Monzani, V.; Skogen, V.; Keitel, V.; Kopfnagel, V.; Friaiza, V.; Andrade, V.; Moreno, V.; Albrecht, W.; Peter, W.; Poller, W.; Farre, X.; Yi, X.; Wang, X.; Khodamoradi, Y.; Karadeniz, Z.; Latiano, A.; Goerg, S.; Bacher, P.; Koehler, P.; Tran, F.; Zoller, H.; Schulte, E. C.; Heidecker, B.; Ludwig, K. U.; Fernandez, J.; Romero-Gomez, M.; Albillos, A.; Invernizzi, P.; Buti, M.; Duga, S.; Bujanda, L.; Hov, J. R.; Lenz, T. L.; Asselta, R.; Cid, R.; Valenti, L.; Karlsen, T. H.; Caceres, M.; Franke, A., Detailed stratified GWAS analysis for severe COVID-19 in four European populations. *Hum Mol Genet* **2022**.
189. Weiner, J.; Suwalski, P.; Holtgrewe, M.; Rakitko, A.; Thibeault, C.; Muller, M.; Patriki, D.; Quedenau, C.; Kruger, U.; Ilinsky, V.; Popov, I.; Balnis, J.; Jaitovich, A.; Helbig, E. T.; Lippert, L. J.; Stubbemann, P.; Real, L. M.; Macias, J.; Pineda, J. A.; Fernandez-Fuertes, M.; Wang, X.; Karadeniz, Z.; Saccomanno, J.; Doehn, J. M.; Hubner, R. H.; Hinzmann, B.; Salvo, M.; Blueher, A.; Siemann, S.; Jurisic, S.; Beer, J. H.; Rutishauser, J.; Wiggli, B.; Schmid, H.; Danninger, K.; Binder, R.; Corman, V. M.; Muhlemann, B.; Arjun Arkal, R.; Fragiadakis, G. K.; Mick, E.; Comet, C.; Calfee, C. S.; Erle, D. J.; Hendrickson, C. M.; Kangelaris, K. N.; Krummel, M. F.; Woodruff, P. G.; Langelier, C. R.; Venkataramani, U.; Garcia, F.; Zyla, J.; Drosten, C.; Alice, B.; Jones, T. C.; Suttorp, N.; Witzernath, M.; Hippenstiel, S.; Zemojtel, T.; Skurk, C.; Wolfgang, P.; Borodina, T.; Pa-Covid, S. G.; Ripke, S.; Sander, L. E.; Beule, D.; Landmesser, U.; Guettouche, T.; Kurth, F.; Heidecker, B., Increased risk of severe clinical course of COVID-19 in carriers of HLA-C\*04:01. *EclinicalMedicine* **2021**, *40*, 101099.
190. Dannebaum, R.; Suwalski, P.; Asgharian, H.; Du Zhipei, G.; Lin, H.; Weiner, J.; Holtgrewe, M.; Thibeault, C.; Muller, M.; Wang, X.; Karadeniz, Z.; Saccomanno, J.; Doehn, J. M.; Hubner, R. H.; Hinzmann, B.; Bluher, A.; Siemann, S.; Telman, D.; Suttorp, N.; Witzernath, M.; Hippenstiel, S.; Skurk, C.; Poller, W.; Sander, L. E.; Beule, D.; Kurth, F.; Guettouche, T.; Landmesser, U.; Berka, J.; Luong, K.; Pa, C. S. G.; Rubelt, F.; Heidecker, B., Highly multiplexed immune repertoire sequencing links multiple lymphocyte classes with severity of response to COVID-19. *Eclinical Medicine* **2022**, *48*, 101438.
191. Initiative, C.-H. G., Mapping the human genetic architecture of COVID-19. *Nature* **2021**, *600*, (7889), 472-477.

192. Schultheiss, C.; Paschold, L.; Simnica, D.; Mohme, M.; Willscher, E.; von Wenserski, L.; Scholz, R.; Wieters, I.; Dahlke, C.; Tolosa, E.; Sedding, D. G.; Ciesek, S.; Addo, M.; Binder, M., Next-Generation Sequencing of T and B Cell Receptor Repertoires from COVID-19 Patients Showed Signatures Associated with Severity of Disease. *Immunity* **2020**, *53*, (2), 442-455 e4.
193. Wagner, J. U. G.; Bojkova, D.; Shumliakivska, M.; Luxan, G.; Nicin, L.; Aslan, G. S.; Milting, H.; Kandler, J. D.; Dendorfer, A.; Heumueller, A. W.; Fleming, I.; Bibli, S. I.; Jakobi, T.; Dieterich, C.; Zeiher, A. M.; Ciesek, S.; Cinatl, J.; Dimmeler, S., Increased susceptibility of human endothelial cells to infections by SARS-CoV-2 variants. *Basic Res Cardiol* **2021**, *116*, (1), 42.
194. Combes, A. J.; Courau, T.; Kuhn, N. F.; Hu, K. H.; Ray, A.; Chen, W. S.; Chew, N. W.; Cleary, S. J.; Kushnoor, D.; Reeder, G. C.; Shen, A.; Tsui, J.; Hiam-Galvez, K. J.; Munoz-Sandoval, P.; Zhu, W. S.; Lee, D. S.; Sun, Y.; You, R.; Magnen, M.; Rodriguez, L.; Im, K. W.; Serwas, N. K.; Leligdowicz, A.; Zamecnik, C. R.; Loudermilk, R. P.; Wilson, M. R.; Ye, C. J.; Fragiadakis, G. K.; Looney, M. R.; Chan, V.; Ward, A.; Carrillo, S.; Consortium, U. C.; Matthay, M.; Erle, D. J.; Woodruff, P. G.; Langelier, C.; Kangelaris, K.; Hendrickson, C. M.; Calfee, C.; Rao, A. A.; Krummel, M. F., Global absence and targeting of protective immune states in severe COVID-19. *Nature* **2021**, *591*, (7848), 124-130.
195. Hoffmann, H. H.; Sanchez-Rivera, F. J.; Schneider, W. M.; Luna, J. M.; Soto-Feliciano, Y. M.; Ashbrook, A. W.; Le Pen, J.; Leal, A. A.; Ricardo-Lax, I.; Michailidis, E.; Hao, Y.; Stenzel, A. F.; Peace, A.; Zuber, J.; Allis, C. D.; Lowe, S. W.; MacDonald, M. R.; Poirier, J. T.; Rice, C. M., Functional interrogation of a SARS-CoV-2 host protein interactome identifies unique and shared coronavirus host factors. *Cell Host Microbe* **2021**, *29*, (2), 267-280 e5.
196. van der Made, C. I.; Netea, M. G.; van der Veerdonk, F. L.; Hoischen, A., Clinical implications of host genetic variation and susceptibility to severe or critical COVID-19. *Genome Med* **2022**, *14*, (1), 96.
197. Roberts, G. H. L.; Partha, R.; Rhead, B.; Knight, S. C.; Park, D. S.; Coignet, M. V.; Zhang, M.; Berkowitz, N.; Turrisini, D. A.; Gaddis, M.; McCurdy, S. R.; Pavlovic, M.; Ruiz, L.; Sass, C.; Ancestry, D. N. A. S. T.; Haug Baltzell, A. K.; Guturu, H.; Girshick, A. R.; Ball, C. A.; Hong, E. L.; Rand, K. A., Expanded COVID-19 phenotype definitions reveal distinct patterns of genetic association and protective effects. *Nat Genet* **2022**, *54*, (4), 374-381.
198. Peloso, G. M.; Tcheandjieu, C.; McGeary, J. E.; Posner, D. C.; Ho, Y. L.; Zhou, J. J.; Hilliard, A. T.; Joseph, J.; O'Donnell, C. J.; Efir, J. T.; Crawford, D. C.; Wu, W. C.; Arjomandi, M.; Initiative, V. A. M. V. P. C.-S.; Sun, Y. V.; Assimes, T. L.; Huffman, J. E., Genetic Loci Associated With COVID-19 Positivity and Hospitalization in White, Black, and Hispanic Veterans of the VA Million Veteran Program. *Front Genet* **2021**, *12*, 777076.
199. Cruz, R.; Almeida, S. D.; Heredia, M. L.; Quintela, I.; Ceballos, F. C.; Pita, G.; Lorenzo-Salazar, J. M.; Gonzalez-Montelongo, R.; Gago-Dominguez, M.; Porras, M. S.; Castano, J. A. T.; Nevado, J.; Aguado, J. M.; Aguilar, C.; Aguilera-Albesa, S.; Almadana, V.; Almoguera, B.; Alvarez, N.; Andreu-Bernabeu, A.; Arana-Arri, E.; Arango, C.; Arranz, M. J.; Artiga, M. J.; Baptista-Rosas, R. C.; Barreda-Sanchez, M.; Belhassen-Garcia, M.; Bezerra, J. F.; Bezerra, M. A. C.; Boix-Palop, L.; Brion, M.; Brugada, R.; Bustos, M.; Calderon, E. J.; Carbonell, C.; Castano, L.; Castela, J. E.; Conde-Vicente, R.; Cordero-Lorenzana, M. L.; Cortes-Sanchez, J. L.; Corton, M.; Darnaude, M. T.; De Martino-Rodriguez, A.; Campo-Perez, V.; Bustamante, A. D.; Dominguez-Garrido, E.; Luchessi, A. D.; Eiros, R.; Sanabria, G. M. E.; Farinas, M. C.; Fernandez-Robelo, U.; Fernandez-Rodriguez, A.; Fernandez-Villa, T.; Gil-Fournier, B.; Gomez-Arrue, J.; Alvarez, B. G.; Quiros, F. G. B.; Gonzalez-Penas, J.; Gutierrez-Bautista, J. F.; Herrero, M. J.; Herrero-Gonzalez, A.; Jimenez-Sousa, M. A.; Lattig, M. C.; Borja, A. L.; Lopez-Rodriguez, R.; Mancebo, E.; Martin-Lopez, C.; Martin, V.; Martinez-Nieto, O.; Martinez-Lopez, I.; Martinez-Resendez, M. F.; Martinez-Perez, A.; Mazzeu, J. A.; Macias, E. M.; Minguez, P.; Cuerda, V. M.; Silbiger, V. N.; Oliveira, S. F.; Ortega-Paino, E.; Parellada, M.; Paz-Artal, E.; Santos, N. P. C.; Perez-Matute, P.; Perez, P.; Perez-Tomas, M. E.; Peruch, T.; Pinsach-Abuin, M. L.; Pompa-Mera, E. N.; Porras-Hurtado, G. L.; Pujol, A.; Leon, S. R.; Resino, S.; Fernandes, M. R.; Rodriguez-Ruiz, E.; Rodriguez-Artalejo, F.; Rodriguez-Garcia, J. A.; Ruiz-Cabello, F.; Ruiz-Hornillos, J.; Ryan, P.; Soria, J. M.; Souto, J. C.; Tamayo, E.; Tamayo-Velasco, A.; Taracido-Fernandez, J. C.; Teper, A.; Torres-Tobar, L.; Urioste, M.; Valencia-Ramos, J.; Yanez, Z.; Zarate, R.; Nakanishi, T.; Pigazzini, S.; Degenhardt, F.; Butler-Laporte, G.; Maya-Miles, D.; Bujanda, L.; Bouysran, Y.; Palom, A.; Ellinghaus, D.; Martinez-Bueno, M.; Rolker, S.; Amitrano, S.; Roade, L.; Fava, F.; Spinner, C. D.; Prati, D.; Bernardo, D.; Garcia, F.; Darcis, G.; Fernandez-Cadenas, I.; Holter, J. C.; Banales, J. M.; Frithiof, R.; Duga, S.; Asselta, R.; Pereira, A. C.; Romero-Gomez, M.; Nafria-Jimenez, B.; Hov, J. R.; Migeotte, I.; Renieri, A.; Planas, A. M.; Ludwig, K. U.; Buti, M.; Rahmouni, S.; Alarcon-Riquelme, M. E.; Schulte, E. C.; Franke, A.; Karlsen, T. H.; Valenti, L.; Zeberg, H.; Richards, B.; Ganna, A.; Boada, M.; Rojas, I.; Ruiz, A.; Sanchez, P.; Real, L. M.; Group, S. C.; Group, H. C.; Group, G. C. C.; Guillen-Navarro, E.; Ayuso, C.; Gonzalez-Neira, A.; Riancho, J. A.; Rojas-Martinez, A.; Flores, C.; Lapunzina, P.; Carracedo, A., Novel genes and sex differences in COVID-19 severity. *Hum Mol Genet* **2022**.
200. Nakanishi, T.; Pigazzini, S.; Degenhardt, F.; Cordioli, M.; Butler-Laporte, G.; Maya-Miles, D.; Bujanda, L.; Bouysran, Y.; Niemi, M. E.; Palom, A.; Ellinghaus, D.; Khan, A.; Martinez-Bueno, M.; Rolker, S.; Amitrano, S.; Roade Tato, L.; Fava, F.; FinnGen; Initiative, C.-H. G.; Spinner, C. D.; Prati, D.; Bernardo, D.; Garcia, F.; Darcis, G.; Fernandez-Cadenas, I.; Holter, J. C.; Banales, J. M.; Frithiof, R.; Kiryluk, K.; Duga, S.; Asselta, R.; Pereira, A. C.; Romero-Gomez, M.; Nafria-Jimenez, B.; Hov, J. R.; Migeotte, I.; Renieri, A.; Planas, A. M.; Ludwig, K. U.; Buti, M.; Rahmouni, S.; Alarcon-Riquelme, M. E.; Schulte, E. C.; Franke, A.; Karlsen, T. H.; Valenti, L.; Zeberg, H.; Richards, J. B.; Ganna, A., Age-dependent impact of the major common genetic risk factor for COVID-19 on severity and mortality. *J Clin Invest* **2021**, *131*, (23).
201. Severe Covid, G. G.; Ellinghaus, D.; Degenhardt, F.; Bujanda, L.; Buti, M.; Albillos, A.; Invernizzi, P.; Fernandez, J.; Prati, D.; Baselli, G.; Asselta, R.; Grimsrud, M. M.; Milani, C.; Aziz, F.; Kassens, J.; May, S.; Wendorff, M.; Wienbrandt, L.; Uellendahl-

- Werth, F.; Zheng, T.; Yi, X.; de Pablo, R.; Chercoles, A. G.; Palom, A.; Garcia-Fernandez, A. E.; Rodriguez-Frias, F.; Zanella, A.; Bandera, A.; Protti, A.; Aghemo, A.; Lleo, A.; Biondi, A.; Caballero-Garralda, A.; Gori, A.; Tanck, A.; Carreras Nolla, A.; Latiano, A.; Fracanzani, A. L.; Peschuck, A.; Julia, A.; Pesenti, A.; Voza, A.; Jimenez, D.; Mateos, B.; Nafria Jimenez, B.; Quereda, C.; Paccapelo, C.; Gassner, C.; Angelini, C.; Cea, C.; Solier, A.; Pestana, D.; Muniz-Diaz, E.; Sandoval, E.; Paraboschi, E. M.; Navas, E.; Garcia Sanchez, F.; Ceriotti, F.; Martinelli-Boneschi, F.; Peyvandi, F.; Blasi, F.; Tellez, L.; Blanco-Grau, A.; Hemmrich-Stanisak, G.; Grasselli, G.; Costantino, G.; Cardamone, G.; Foti, G.; Aneli, S.; Kurihara, H.; ElAbd, H.; My, I.; Galvan-Femenia, I.; Martin, J.; Erdmann, J.; Ferrusquia-Acosta, J.; Garcia-Etxebarria, K.; Izquierdo-Sanchez, L.; Bettini, L. R.; Sumoy, L.; Terranova, L.; Moreira, L.; Santoro, L.; Scudeller, L.; Mesonero, F.; Roade, L.; Ruhlemann, M. C.; Schaefer, M.; Carrabba, M.; Riveiro-Barciela, M.; Figuera Basso, M. E.; Valsecchi, M. G.; Hernandez-Tejero, M.; Acosta-Herrera, M.; D'Angio, M.; Baldini, M.; Cazzaniga, M.; Schulzky, M.; Cecconi, M.; Wittig, M.; Ciccarelli, M.; Rodriguez-Gandia, M.; Bociolone, M.; Miozzo, M.; Montano, N.; Braun, N.; Sacchi, N.; Martinez, N.; Ozer, O.; Palmieri, O.; Faverio, P.; Preatoni, P.; Bonfanti, P.; Omodei, P.; Tentorio, P.; Castro, P.; Rodrigues, P. M.; Blandino Ortiz, A.; de Cid, R.; Ferrer, R.; Gualtierotti, R.; Nieto, R.; Goerg, S.; Badalamenti, S.; Marsal, S.; Matullo, G.; Pelusi, S.; Juzenas, S.; Aliberti, S.; Monzani, V.; Moreno, V.; Wesse, T.; Lenz, T. L.; Pumarola, T.; Rimoldi, V.; Bosari, S.; Albrecht, W.; Peter, W.; Romero-Gomez, M.; D'Amato, M.; Duga, S.; Banales, J. M.; Hov, J. R.; Folseraas, T.; Valenti, L.; Franke, A.; Karlsen, T. H., Genomewide Association Study of Severe Covid-19 with Respiratory Failure. *N Engl J Med* **2020**, *383*, (16), 1522-1534.
202. Lee, Y.; Riskedal, E.; Kalleberg, K. T.; Istre, M.; Lind, A.; Lund-Johansen, F.; Reiakvam, O.; Soraas, A. V. L.; Harris, J. R.; Dahl, J. A.; Hadley, C. L.; Jugessur, A., EWAS of post-COVID-19 patients shows methylation differences in the immune-response associated gene, IFI44L, three months after COVID-19 infection. *Sci Rep* **2022**, *12*, (1), 11478.
203. The COVID-19 Host Genetics Initiative (COVID-19 HGI) <https://www.covid19hg.org/>
204. Roth, G. A.; Vaduganathan, M.; Mensah, G. A., Impact of the COVID-19 Pandemic on Cardiovascular Health in 2020: JACC State-of-the-Art Review. *J Am Coll Cardiol* **2022**, *80*, (6), 631-640.
205. Nadarajah, R.; Wu, J.; Hurdus, B.; Asma, S.; Bhatt, D. L.; Biondi-Zoccai, G.; Mehta, L. S.; Ram, C. V. S.; Ribeiro, A. L. P.; Van Spall, H. G. C.; Deanfield, J. E.; Luscher, T. F.; Mamas, M.; Gale, C. P., The collateral damage of COVID-19 to cardiovascular services: a meta-analysis. *Eur Heart J* **2022**, *43*, (33), 3164-3178.
206. Task Force for the management of, C.-o. t. E. S. o. C., European Society of Cardiology guidance for the diagnosis and management of cardiovascular disease during the COVID-19 pandemic: part 1-epidemiology, pathophysiology, and diagnosis. *Eur Heart J* **2022**, *43*, (11), 1033-1058.
207. Task Force for the management of, C.-o. t. E. S. o. C., ESC guidance for the diagnosis and management of cardiovascular disease during the COVID-19 pandemic: part 2-care pathways, treatment, and follow-up. *Eur Heart J* **2022**, *43*, (11), 1059-1103.
208. Matar, R. H.; Mansour, R.; Nakanishi, H.; Smayra, K.; El Haddad, J.; Vankayalapati, D. K.; Daniel, R. S.; Tosovic, D.; Than, C. A.; Yamani, M. H., Clinical Characteristics of Patients with Myocarditis following COVID-19 mRNA Vaccination: A Systematic Review and Meta-Analysis. *J Clin Med* **2022**, *11*, (15).
209. Liu, L.; Jing, H.; Wu, X.; Xiang, M.; Novakovic, V. A.; Wang, S.; Shi, J., The cross-talk of lung and heart complications in COVID-19: Endothelial cells dysfunction, thrombosis, and treatment. *Front Cardiovasc Med* **2022**, *9*, 957006.
210. Raman, B.; Bluemke, D. A.; Luscher, T. F.; Neubauer, S., Long COVID: post-acute sequelae of COVID-19 with a cardiovascular focus. *Eur Heart J* **2022**, *43*, (11), 1157-1172.
211. Morrow, A.; Gray, S. R.; Bayes, H. K.; Sykes, R.; McGarry, E.; Anderson, D.; Boiskin, D.; Burke, C.; Cleland, J. G. F.; Goodyear, C.; Ibbotson, T.; Lang, C. C.; McConnachie, Mair, F.; Mangion, K.; Patel, M.; Sattar, N.; Taggart, D.; Taylor, R.; Dawkes, S.; Berry, C., Prevention and early treatment of the long-term physical effects of COVID-19 in adults: design of a randomised controlled trial of resistance exercise-CISCO-21. *Trials* **2022**, *23*, (1), 660.
212. Gang, J.; Wang, H.; Xue, X.; Zhang, S., Microbiota and COVID-19: Long-term and complex influencing factors. *Front Microbiol* **2022**, *13*, 963488.
213. Joseph, M.; Wu, Y.; Dannebaum, R.; Rubelt, F.; Zlatareva, I.; Lorenc, A.; Du, Z. G.; Davies, D.; Kyle-Cezar, F.; Das, A.; Gee, S.; Seow, J.; Graham, C.; Telman, D.; Bermejo, C.; Lin, H.; Asgharian, H.; Laing, A. G.; Del Molino Del Barrio, I.; Monin, L.; Munoz-Ruiz, M.; McKenzie, D. R.; Hayday, T. S.; Francos-Quijorna, I.; Kamdar, S.; Davis, R.; Sofra, V.; Cano, F.; Theodoridis, E.; Martinez, L.; Merrick, B.; Bisnauthsing, K.; Brooks, K.; Edgeworth, J.; Cason, J.; Mant, C.; Doores, K. J.; Vantourout, P.; Luong, K.; Berka, J.; Hayday, A. C., Global patterns of antigen receptor repertoire disruption across adaptive immune compartments in COVID-19. *Proc Natl Acad Sci U S A* **2022**, *119*, (34), e2201541119.
214. Viswanathan, K.; Dhabhar, F. S., Stress-induced enhancement of leukocyte trafficking into sites of surgery or immune activation. *Proc Natl Acad Sci U S A* **2005**, *102*, (16), 5808-13.
215. Dhabhar, F. S.; Malarkey, W. B.; Neri, E.; McEwen, B. S., Stress-induced redistribution of immune cells--from barracks to boulevards to battlefields: a tale of three hormones--Curt Richter Award winner. *Psychoneuroendocrinology* **2012**, *37*, (9), 1345-68.
216. Glaser, R.; Kiecolt-Glaser, J. K., Stress-induced immune dysfunction: implications for health. *Nat Rev Immunol* **2005**, *5*, (3), 243-51.

217. Papaioannou, S.; Medini, P., Advantages, Pitfalls, and Developments of All Optical Interrogation Strategies of Microcircuits in vivo. *Front Neurosci* **2022**, *16*, 859803.
218. Teratani, T.; Mikami, Y.; Kanai, T., Neuroimmune crosstalk in the gut and liver. *Int Immunol* **2022**.
219. Madrid, M. K.; Brennan, J. A.; Yin, R. T.; Knight, H. S.; Efimov, I. R., Advances in Implantable Optogenetic Technology for Cardiovascular Research and Medicine. *Front Physiol* **2021**, *12*, 720190.
220. Arenkiel, B. R.; Peca, J.; Davison, I. G.; Feliciano, C.; Deisseroth, K.; Augustine, G. J.; Ehlers, M. D.; Feng, G., In vivo light-induced activation of neural circuitry in transgenic mice expressing channelrhodopsin-2. *Neuron* **2007**, *54*, (2), 205-18.
221. Ayling, O. G.; Harrison, T. C.; Boyd, J. D.; Goroshkov, A.; Murphy, T. H., Automated light-based mapping of motor cortex by photoactivation of channelrhodopsin-2 transgenic mice. *Nat Methods* **2009**, *6*, (3), 219-24.
222. Erben, L.; Welday, J. P.; Murphy, R.; Buonanno, A., Toxic and Phenotypic Effects of AAV\_Cre Used to Transduce Mesencephalic Dopaminergic Neurons. *Int J Mol Sci* **2022**, *23*, (16).
223. Patel, D. D.; Marsic, D.; Periasamy, R.; Zolotukhin, S.; Lipinski, D. M., Identification of Novel Retinal Pericyte-Targeting rAAV Vectors Through Directed Evolution. *Transl Vis Sci Technol* **2022**, *11*, (8), 28.
224. Van Hove, H.; Martens, L.; Scheyltjens, I.; De Vlaminck, K.; Pombo Antunes, A. R.; De Prijck, S.; Vandamme, N.; De Schepper, S.; Van Isterdael, G.; Scott, C. L.; Aerts, J.; Berx, G.; Boeckxstaens, G. E.; Vandenbroucke, R. E.; Vereecke, L.; Moechars, D.; Guillems, M.; Van Ginderachter, J. A.; Saeys, Y.; Movahedi, K., A single-cell atlas of mouse brain macrophages reveals unique transcriptional identities shaped by ontogeny and tissue environment. *Nat Neurosci* **2019**, *22*, (6), 1021-1035.
225. Mrdjen, D.; Pavlovic, A.; Hartmann, F. J.; Schreiner, B.; Utz, S. G.; Leung, B. P.; Lelios, I.; Heppner, F. L.; Kipnis, J.; Merkler, D.; Greter, M.; Becher, B., High-Dimensional Single-Cell Mapping of Central Nervous System Immune Cells Reveals Distinct Myeloid Subsets in Health, Aging, and Disease. *Immunity* **2018**, *48*, (2), 380-395 e6.
226. Golomb, S. M.; Guldner, I. H.; Zhao, A.; Wang, Q.; Palakurthi, B.; Aleksandrovic, E. A.; Lopez, J. A.; Lee, S. W.; Yang, K.; Zhang, S., Multi-modal Single-Cell Analysis Reveals Brain Immune Landscape Plasticity during Aging and Gut Microbiota Dysbiosis. *Cell Rep* **2020**, *33*, (9), 108438.
227. Gut microbiome dysbiosis is associated with increased mortality after solid organ transplantation. <https://www.science.org/doi/epdf/10.1126/scitranslmed.abn7566>
228. West, P. T.; Chanin, R. B.; Bhatt, A. S., From genome structure to function: insights into structural variation in microbiology. *Curr Opin Microbiol* **2022**, *69*, 102192.
229. Schulz, F.; Abergel, C.; Woyke, T., Giant virus biology and diversity in the era of genome-resolved metagenomics. *Nat Rev Microbiol* **2022**.
230. Mostafa-Hedeab, G.; Allayeh, A. K.; Elhady, H. A.; Eledrery, A. Y.; Mraheil, M. A.; Mostafa, A., Viral Eco-Genomic Tools: Development and Implementation for Aquatic Biomonitoring. *Int J Environ Res Public Health* **2022**, *19*, (13).
231. Privitera, G. F.; Alaimo, S.; Ferro, A.; Pulvirenti, A., Virus finding tools: current solutions and limitations. *Brief Bioinform* **2022**, *23*, (4).
232. Stenglein, M. D., The Case for Studying New Viruses of New Hosts. *Annu Rev Virol* **2022**.
233. Zimmermann, F.; Roessler, J.; Schmidt, D.; Jasina, A.; Schumann, P.; Gast, M.; Poller, W.; Leistner, D.; Giral, H.; Krankel, N.; Kratzer, A.; Schuchardt, S.; Heimesaat, M. M.; Landmesser, U.; Haghikia, A., Impact of the Gut Microbiota on Atorvastatin Mediated Effects on Blood Lipids. *J Clin Med* **2020**, *9*, (5).
234. Haghikia, A.; Zimmermann, F.; Schumann, P.; Jasina, A.; Roessler, J.; Schmidt, D.; Heinze, P.; Kaisler, J.; Nageswaran, V.; Aigner, A.; Ceglarek, U.; Cineus, R.; Hegazy, A. N.; van der Vorst, E. P. C.; Doring, Y.; Strauch, C. M.; Nemet, I.; Tremaroli, V.; Dwibedi, C.; Krankel, N.; Leistner, D. M.; Heimesaat, M. M.; Bereswill, S.; Rauch, G.; Seeland, U.; Soehnlein, O.; Muller, D. N.; Gold, R.; Backhed, F.; Hazen, S. L.; Haghikia, A.; Landmesser, U., Propionate attenuates atherosclerosis by immune-dependent regulation of intestinal cholesterol metabolism. *Eur Heart J* **2022**, *43*, (6), 518-533.
235. Quigley, E. M. M., Microbiota-Brain-Gut Axis and Neurodegenerative Diseases. *Curr Neurol Neurosci Rep* **2017**, *17*, (12), 94.
236. Agirman, G.; Yu, K. B.; Hsiao, E. Y., Signaling inflammation across the gut-brain axis. *Science* **2021**, *374*, (6571), 1087-1092.
237. Jensterle, M.; Herman, R.; Janez, A.; Mahmeed, W. A.; Al-Rasadi, K.; Al-Alawi, K.; Banach, M.; Banerjee, Y.; Ceriello, A.; Cesur, M.; Cosentino, F.; Galia, M.; Goh, S. Y.; Kalra, S.; Kempler, P.; Lessan, N.; Lotufo, P.; Papanas, N.; Rizvi, A. A.; Santos, R. D.; Stoian, A. P.; Toth, P. P.; Viswanathan, V.; Rizzo, M., The Relationship between COVID-19 and Hypothalamic-Pituitary-Adrenal Axis: A Large Spectrum from Glucocorticoid Insufficiency to Excess-The CAPISCO International Expert Panel. *Int J Mol Sci* **2022**, *23*, (13).
238. Lechner, K.; von Schacky, C.; McKenzie, A. L.; Worm, N.; Nixdorff, U.; Lechner, B.; Krankel, N.; Halle, M.; Krauss, R. M.; Scherr, J., Lifestyle factors and high-risk atherosclerosis: Pathways and mechanisms beyond traditional risk factors. *Eur J Prev Cardiol* **2020**, *27*, (4), 394-406.
239. Piepoli, M. F.; Hoes, A. W.; Agewall, S.; Albus, C.; Brotons, C.; Catapano, A. L.; Cooney, M. T.; Corra, U.; Cosyns, B.; Deaton, C.; Graham, I.; Hall, M. S.; Hobbs, F. D. R.; Locher, M. L.; Lollgen, H.; Marques-Vidal, P.; Perk, J.; Prescott, E.; Redon, J.; Richter, D.

- J.; Sattar, N.; Smulders, Y.; Tiberi, M.; van der Worp, H. B.; van Dis, I.; Verschuren, W. M. M.; Binno, S.; Group, E. S. C. S. D., 2016 European Guidelines on cardiovascular disease prevention in clinical practice: The Sixth Joint Task Force of the European Society of Cardiology and Other Societies on Cardiovascular Disease Prevention in Clinical Practice (constituted by representatives of 10 societies and by invited experts) Developed with the special contribution of the European Association for Cardiovascular Prevention & Rehabilitation (EACPR). *Eur Heart J* **2016**, *37*, (29), 2315-2381.
240. Travers, G.; Kippelen, P.; Trangmar, S. J.; Gonzalez-Alonso, J., Physiological Function during Exercise and Environmental Stress in Humans-An Integrative View of Body Systems and Homeostasis. *Cells* **2022**, *11*, (3).
241. Dragano, N.; Siegrist, J.; Nyberg, S. T.; Lunau, T.; Fransson, E. I.; Alfredsson, L.; Bjorner, J. B.; Borritz, M.; Burr, H.; Erbel, R.; Fahlen, G.; Goldberg, M.; Hamer, M.; Heikkila, K.; Jockel, K. H.; Knutsson, A.; Madsen, I. E. H.; Nielsen, M. L.; Nordin, M.; Oksanen, T.; Pejtersen, J. H.; Pentti, J.; Rugulies, R.; Salo, P.; Schupp, J.; Singh-Manoux, A.; Steptoe, A.; Theorell, T.; Vahtera, J.; Westerholm, P. J. M.; Westerlund, H.; Virtanen, M.; Zins, M.; Batty, G. D.; consortium, I. P.-W., Effort-Reward Imbalance at Work and Incident Coronary Heart Disease: A Multicohort Study of 90,164 Individuals. *Epidemiology* **2017**, *28*, (4), 619-626.
242. Czura, C. J.; Bikson, M.; Charvet, L.; Chen, J. D. Z.; Franke, M.; Fudim, M.; Grigsby, E.; Hamner, S.; Huston, J. M.; Khodaparast, N.; Krames, E.; Simon, B. J.; Staats, P.; Vonck, K., Neuromodulation Strategies to Reduce Inflammation and Improve Lung Complications in COVID-19 Patients. *Front Neurol* **2022**, *13*, 897124.
243. O'Donnell, C. J.; Schwartz Longacre, L.; Cohen, B. E.; Fayad, Z. A.; Gillespie, C. F.; Liberzon, I.; Pathak, G. A.; Polimanti, R.; Risbrough, V.; Ursano, R. J.; Vander Heide, R. S.; Yancy, C. W.; Vaccarino, V.; Sopko, G.; Stein, M. B., Posttraumatic Stress Disorder and Cardiovascular Disease: State of the Science, Knowledge Gaps, and Research Opportunities. *JAMA Cardiol* **2021**, *6*, (10), 1207-1216.
244. Zhang, X.; Lei, B.; Yuan, Y.; Zhang, L.; Hu, L.; Jin, S.; Kang, B.; Liao, X.; Sun, W.; Xu, F.; Zhong, Y.; Hu, J.; Qi, H., Brain control of humoral immune responses amenable to behavioural modulation. *Nature* **2020**, *581*, (7807), 204-208.
245. Xu, C.; Lee, S. K.; Zhang, D.; Frenette, P. S., The Gut Microbiome Regulates Psychological-Stress-Induced Inflammation. *Immunity* **2020**, *53*, (2), 417-428 e4.
246. Abe, C.; Inoue, T.; Inglis, M. A.; Viar, K. E.; Huang, L.; Ye, H.; Rosin, D. L.; Stornetta, R. L.; Okusa, M. D.; Guyenet, P. G., C1 neurons mediate a stress-induced anti-inflammatory reflex in mice. *Nat Neurosci* **2017**, *20*, (5), 700-707.
247. Schiller, M.; Ben-Shaanan, T. L.; Rolls, A., Neuronal regulation of immunity: why, how and where? *Nat Rev Immunol* **2021**, *21*, (1), 20-36.
248. Poller, W. C.; Downey, J.; Mooslechner, A. A.; Khan, N.; Li, L.; Chan, C. T.; McAlpine, C. S.; Xu, C.; Kahles, F.; He, S.; Janssen, H.; Mindur, J. E.; Singh, S.; Kiss, M. G.; Alonso-Herranz, L.; Iwamoto, Y.; Kohler, R. H.; Wong, L. P.; Chetal, K.; Russo, S. J.; Sadreyev, R. I.; Weissleder, R.; Nahrendorf, M.; Frenette, P. S.; Divangahi, M.; Swirski, F. K., Brain motor and fear circuits regulate leukocytes during acute stress. *Nature* **2022**, *607*, (7919), 578-584.
249. McAlpine, C. S.; Kiss, M. G.; Rattik, S.; He, S.; Vassalli, A.; Valet, C.; Anzai, A.; Chan, C. T.; Mindur, J. E.; Kahles, F.; Poller, W. C.; Frodermann, V.; Fenn, A. M.; Gregory, A. F.; Halle, L.; Iwamoto, Y.; Hoyer, F. F.; Binder, C. J.; Libby, P.; Tafti, M.; Scammell, T. E.; Nahrendorf, M.; Swirski, F. K., Sleep modulates haematopoiesis and protects against atherosclerosis. *Nature* **2019**, *566*, (7744), 383-387.
250. Poller, W. C.; Nahrendorf, M.; Swirski, F. K., Hematopoiesis and Cardiovascular Disease. *Circ Res* **2020**, *126*, (8), 1061-1085.
251. McAlpine, C. S.; Kiss, M. G.; Zuraiat, F. M.; Cheek, D.; Schioli, G.; Amatullah, H.; Huynh, P.; Bhatti, M. Z.; Wong, L. P.; Yates, A. G.; Poller, W. C.; Mindur, J. E.; Chan, C. T.; Janssen, H.; Downey, J.; Singh, S.; Sadreyev, R. I.; Nahrendorf, M.; Jeffrey, K. L.; Scadden, D. T.; Naxerova, K.; St-Onge, M. P.; Swirski, F. K., Sleep exerts lasting effects on hematopoietic stem cell function and diversity. *J Exp Med* **2022**, *219*, (11).
252. Cryan, J. F.; O'Riordan, K. J.; Cowan, C. S. M.; Sandhu, K. V.; Bastiaanssen, T. F. S.; Boehme, M.; Codagnone, M. G.; Cussotto, S.; Fulling, C.; Golubeva, A. V.; Guzzetta, K. E.; Jaggar, M.; Long-Smith, C. M.; Lyte, J. M.; Martin, J. A.; Molinero-Perez, A.; Moloney, G.; Morelli, E.; Morillas, E.; O'Connor, R.; Cruz-Pereira, J. S.; Peterson, V. L.; Rea, K.; Ritz, N. L.; Sherwin, E.; Spichak, S.; Teichman, E. M.; van de Wouw, M.; Ventura-Silva, A. P.; Wallace-Fitzsimons, S. E.; Hyland, N.; Clarke, G.; Dinan, T. G., The Microbiota-Gut-Brain Axis. *Physiol Rev* **2019**, *99*, (4), 1877-2013.
253. Mayer, E. A.; Nance, K.; Chen, S., The Gut-Brain Axis. *Annu Rev Med* **2022**, *73*, 439-453.
254. Yu, L. W.; Agirman, G.; Hsiao, E. Y., The Gut Microbiome as a Regulator of the Neuroimmune Landscape. *Annu Rev Immunol* **2022**, *40*, 143-167.
255. Bosi, A.; Banfi, D.; Bistoletti, M.; Moretto, P.; Moro, E.; Crema, F.; Maggi, F.; Karousou, E.; Viola, M.; Passi, A.; Vigetti, D.; Giaroni, C.; Baj, A., Hyaluronan: A Neuroimmune Modulator in the Microbiota-Gut Axis. *Cells* **2021**, *11*, (1).
256. Klein Wolterink, R. G. J.; Wu, G. S.; Chiu, I. M.; Veiga-Fernandes, H., Neuroimmune Interactions in Peripheral Organs. *Annu Rev Neurosci* **2022**, *45*, 339-360.
257. Howard, E. J.; Lam, T. K. T.; Duca, F. A., The Gut Microbiome: Connecting Diet, Glucose Homeostasis, and Disease. *Annu Rev Med* **2022**, *73*, 469-481.

258. Agirman, G.; Hsiao, E. Y., SnapShot: The microbiota-gut-brain axis. *Cell* **2021**, *184*, (9), 2524-2524 e1.
259. Mowat, A. M.; Agace, W. W., Regional specialization within the intestinal immune system. *Nat Rev Immunol* **2014**, *14*, (10), 667-85.
260. Jacobson, A.; Yang, D.; Vella, M.; Chiu, I. M., The intestinal neuro-immune axis: crosstalk between neurons, immune cells, and microbes. *Mucosal Immunol* **2021**, *14*, (3), 555-565.
261. Spadoni, I.; Zagato, E.; Bertocchi, A.; Paolinelli, R.; Hot, E.; Di Sabatino, A.; Caprioli, F.; Bottiglieri, L.; Oldani, A.; Viale, G.; Penna, G.; Dejana, E.; Rescigno, M., A gut-vascular barrier controls the systemic dissemination of bacteria. *Science* **2015**, *350*, (6262), 830-4.
262. Rojas, O. L.; Probstel, A. K.; Porfilio, E. A.; Wang, A. A.; Charabati, M.; Sun, T.; Lee, D. S. W.; Galicia, G.; Ramaglia, V.; Ward, L. A.; Leung, L. Y. T.; Najafi, G.; Khaleghi, K.; Garcillan, B.; Li, A.; Besla, R.; Naouar, I.; Cao, E. Y.; Chiaranunt, P.; Burrows, K.; Robinson, H. G.; Allanach, J. R.; Yam, J.; Luck, H.; Campbell, D. J.; Allman, D.; Brooks, D. G.; Tomura, M.; Baumann, R.; Zamvil, S. S.; Bar-Or, A.; Horwitz, M. S.; Winer, D. A.; Mortha, A.; Mackay, F.; Prat, A.; Osborne, L. C.; Robbins, C.; Baranzini, S. E.; Gommerman, J. L., Recirculating Intestinal IgA-Producing Cells Regulate Neuroinflammation via IL-10. *Cell* **2019**, *176*, (3), 610-624 e18.
263. Huh, J. R.; Veiga-Fernandes, H., Neuroimmune circuits in inter-organ communication. *Nat Rev Immunol* **2020**, *20*, (4), 217-228.
264. Zhao, J.; Bi, W.; Xiao, S.; Lan, X.; Cheng, X.; Zhang, J.; Lu, D.; Wei, W.; Wang, Y.; Li, H.; Fu, Y.; Zhu, L., Neuroinflammation induced by lipopolysaccharide causes cognitive impairment in mice. *Sci Rep* **2019**, *9*, (1), 5790.
265. Heiss, C. N.; Manneras-Holm, L.; Lee, Y. S.; Serrano-Lobo, J.; Hakansson Gladh, A.; Seeley, R. J.; Drucker, D. J.; Backhed, F.; Olofsson, L. E., The gut microbiota regulates hypothalamic inflammation and leptin sensitivity in Western diet-fed mice via a GLP-1R-dependent mechanism. *Cell Rep* **2021**, *35*, (8), 109163.
266. Benakis, C.; Martin-Gallausiaux, C.; Trezzi, J. P.; Melton, P.; Liesz, A.; Wilmes, P., The microbiome-gut-brain axis in acute and chronic brain diseases. *Curr Opin Neurobiol* **2020**, *61*, 1-9.
267. Rao, S.; Schieber, A. M. P.; O'Connor, C. P.; Leblanc, M.; Michel, D.; Ayres, J. S., Pathogen-Mediated Inhibition of Anorexia Promotes Host Survival and Transmission. *Cell* **2017**, *168*, (3), 503-516 e12.
268. Kadowaki, A.; Quintana, F. J., The Gut-CNS Axis in Multiple Sclerosis. *Trends Neurosci* **2020**, *43*, (8), 622-634.
269. Fathi, M.; Vakili, K.; Yaghoobpoor, S.; Qadirifard, M. S.; Kosari, M.; Naghsh, N.; Asgari Taei, A.; Klegeris, A.; Dehghani, M.; Bahrami, A.; Taheri, H.; Mohamadkhani, A.; Hajibeygi, R.; Rezaei Tavirani, M.; Sayehmiri, F., Pre-clinical Studies Identifying Molecular Pathways of Neuroinflammation in Parkinson's Disease: A Systematic Review. *Front Aging Neurosci* **2022**, *14*, 855776.
270. Haase, S.; Wilck, N.; Haghikia, A.; Gold, R.; Mueller, D. N.; Linker, R. A., The role of the gut microbiota and microbial metabolites in neuroinflammation. *Eur J Immunol* **2020**, *50*, (12), 1863-1870.
271. Wiendl, H.; Gold, R.; Berger, T.; Derfuss, T.; Linker, R.; Maurer, M.; Aktas, O.; Baum, K.; Berghoff, M.; Bittner, S.; Chan, A.; Czaplinski, A.; Deisenhammer, F.; Di Pauli, F.; Du Pasquier, R.; Enzinger, C.; Fertl, E.; Gass, A.; Gehring, K.; Gobbi, C.; Goebels, N.; Guger, M.; Haghikia, A.; Hartung, H. P.; Heidenreich, F.; Hoffmann, O.; Kallmann, B.; Kleinschnitz, C.; Klotz, L.; Leussink, V. I.; Leutmezer, F.; Limmroth, V.; Lunemann, J. D.; Lutterotti, A.; Meuth, S. G.; Meyding-Lamade, U.; Platten, M.; Rieckmann, P.; Schmidt, S.; Tumani, H.; Weber, F.; Weber, M. S.; Zettl, U. K.; Ziemssen, T.; Zipp, F.; Multiple Sclerosis Therapy Consensus Group, Multiple Sclerosis Therapy Consensus Group (MSTCG): position statement on disease-modifying therapies for multiple sclerosis (white paper). *Ther Adv Neurol Disord* **2021**, *14*, 17562864211039648.
272. Cardoso, F.; Klein Wolterink, R. G. J.; Godinho-Silva, C.; Domingues, R. G.; Ribeiro, H.; da Silva, J. A.; Mahu, I.; Domingos, A. I.; Veiga-Fernandes, H., Neuro-mesenchymal units control ILC2 and obesity via a brain-adipose circuit. *Nature* **2021**, *597*, (7876), 410-414.
273. Bruce-Keller, A. J.; Salbaum, J. M.; Luo, M.; Blanchard, E. t.; Taylor, C. M.; Welsh, D. A.; Berthoud, H. R., Obese-type gut microbiota induce neurobehavioral changes in the absence of obesity. *Biol Psychiatry* **2015**, *77*, (7), 607-15.
274. Margolis, K. G.; Cryan, J. F.; Mayer, E. A., The Microbiota-Gut-Brain Axis: From Motility to Mood. *Gastroenterology* **2021**, *160*, (5), 1486-1501.
275. Socala, K.; Doboszewska, U.; Szopa, A.; Serefko, A.; Wlodarczyk, M.; Zielinska, A.; Poleszak, E.; Fichna, J.; Wlaz, P., The role of microbiota-gut-brain axis in neuropsychiatric and neurological disorders. *Pharmacol Res* **2021**, *172*, 105840.
276. Arya, A. K.; Hu, B., Brain-gut axis after stroke. *Brain Circ* **2018**, *4*, (4), 165-173.
277. Jabczyk, M.; Nowak, J.; Hudzik, B.; Zubelewicz-Szkodzinska, B., Microbiota and Its Impact on the Immune System in COVID-19-A Narrative Review. *J Clin Med* **2021**, *10*, (19).
278. Haghikia, A.; van Mens, T. E.; Pontarollo, G.; Reinhardt, C., Editorial: Impact of the gut microbiota on cardiovascular medicine. *Front Med (Lausanne)* **2022**, *9*, 939890.
279. He, S.; Kahles, F.; Rattik, S.; Nairz, M.; McAlpine, C. S.; Anzai, A.; Selgrade, D.; Fenn, A. M.; Chan, C. T.; Mindur, J. E.; Valet, C.; Poller, W. C.; Halle, L.; Rotllan, N.; Iwamoto, Y.; Wojtkiewicz, G. R.; Weissleder, R.; Libby, P.; Fernandez-Hernando, C.; Drucker,

- D. J.; Nahrendorf, M.; Swirski, F. K., Gut intraepithelial T cells calibrate metabolism and accelerate cardiovascular disease. *Nature* **2019**, 566, (7742), 115-119.
280. Rosshart, S. P.; Herz, J.; Vassallo, B. G.; Hunter, A.; Wall, M. K.; Badger, J. H.; McCulloch, J. A.; Anastasakis, D. G.; Sarshad, A. A.; Leonardi, I.; Collins, N.; Blatter, J. A.; Han, S. J.; Tamoutounour, S.; Potapova, S.; Foster St Claire, M. B.; Yuan, W.; Sen, S. K.; Dreier, M. S.; Hild, B.; Hafner, M.; Wang, D.; Iliev, I. D.; Belkaid, Y.; Trinchieri, G.; Rehermann, B., Laboratory mice born to wild mice have natural microbiota and model human immune responses. *Science* **2019**, 365, (6452).
281. Cugurra, A.; Mamuladze, T.; Rustenhoven, J.; Dykstra, T.; Beroshvili, G.; Greenberg, Z. J.; Baker, W.; Papadopoulos, Z.; Drieu, A.; Blackburn, S.; Kanamori, M.; Brioschi, S.; Herz, J.; Schuettel, L. G.; Colonna, M.; Smirnov, I.; Kipnis, J., Skull and vertebral bone marrow are myeloid cell reservoirs for the meninges and CNS parenchyma. *Science* **2021**, 373, (6553).
282. Brioschi, S.; Wang, W. L.; Peng, V.; Wang, M.; Shchukina, I.; Greenberg, Z. J.; Bando, J. K.; Jaeger, N.; Czepielewski, R. S.; Swain, A.; Mogilenko, D. A.; Beatty, W. L.; Bayguinov, P.; Fitzpatrick, J. A. J.; Schuettel, L. G.; Fronick, C. C.; Smirnov, I.; Kipnis, J.; Shapiro, V. S.; Wu, G. F.; Gilfillan, S.; Cella, M.; Artyomov, M. N.; Kleinstein, S. H.; Colonna, M., Heterogeneity of meningeal B cells reveals a lymphopoietic niche at the CNS borders. *Science* **2021**, 373, (6553).
283. Fitzpatrick, Z.; Frazer, G.; Ferro, A.; Clare, S.; Bouladoux, N.; Ferdinand, J.; Tuong, Z. K.; Negro-Demontel, M. L.; Kumar, N.; Suchanek, O.; Tajsic, T.; Harcourt, K.; Scott, K.; Bashford-Rogers, R.; Helmy, A.; Reich, D. S.; Belkaid, Y.; Lawley, T. D.; McGavern, D. B.; Clatworthy, M. R., Gut-educated IgA plasma cells defend the meningeal venous sinuses. *Nature* **2020**, 587, (7834), 472-476.
284. Sanmarco, L. M.; Wheeler, M. A.; Gutierrez-Vazquez, C.; Polonio, C. M.; Linnerbauer, M.; Pinho-Ribeiro, F. A.; Li, Z.; Giovannoni, F.; Batterman, K. V.; Scalisi, G.; Zandee, S. E. J.; Heck, E. S.; Alsuwailm, M.; Rosene, D. L.; Becher, B.; Chiu, I. M.; Prat, A.; Quintana, F. J., Gut-licensed IFN $\gamma$ (+) NK cells drive LAMP1(+)TRAIL(+) anti-inflammatory astrocytes. *Nature* **2021**, 590, (7846), 473-479.
285. Erny, D.; Hrabé de Angelis, A. L.; Jaitin, D.; Wieghofer, P.; Staszewski, O.; David, E.; Keren-Shaul, H.; Mahlakoiv, T.; Jakobshagen, K.; Buch, T.; Schwierzeck, V.; Utermohlen, O.; Chun, E.; Garrett, W. S.; McCoy, K. D.; Diefenbach, A.; Staeheli, P.; Stecher, B.; Amit, I.; Prinz, M., Host microbiota constantly control maturation and function of microglia in the CNS. *Nat Neurosci* **2015**, 18, (7), 965-77.
286. Thion, M. S.; Low, D.; Silvin, A.; Chen, J.; Grisel, P.; Schulte-Schrepping, J.; Blecher, R.; Ulas, T.; Squarzoni, P.; Hoeffel, G.; Couplier, F.; Siopi, E.; David, F. S.; Scholz, C.; Shihui, F.; Lum, J.; Amoyo, A. A.; Larbi, A.; Poidinger, M.; Buttgerit, A.; Lledo, P. M.; Greter, M.; Chan, J. K. Y.; Amit, I.; Beyer, M.; Schultze, J. L.; Schlitzer, A.; Pettersson, S.; Ginhoux, F.; Garel, S., Microbiome Influences Prenatal and Adult Microglia in a Sex-Specific Manner. *Cell* **2018**, 172, (3), 500-516 e16.
287. Deczkowska, A.; Amit, I.; Schwartz, M., Microglial immune checkpoint mechanisms. *Nat Neurosci* **2018**, 21, (6), 779-786.
288. Alves de Lima, K.; Rustenhoven, J.; Kipnis, J., Meningeal Immunity and Its Function in Maintenance of the Central Nervous System in Health and Disease. *Annu Rev Immunol* **2020**, 38, 597-620.
289. Valdearcos, M.; Robblee, M. M.; Benjamin, D. I.; Nomura, D. K.; Xu, A. W.; Koliwad, S. K., Microglia dictate the impact of saturated fat consumption on hypothalamic inflammation and neuronal function. *Cell Rep* **2014**, 9, (6), 2124-38.
290. Kim, S.; Kim, H.; Yim, Y. S.; Ha, S.; Atarashi, K.; Tan, T. G.; Longman, R. S.; Honda, K.; Littman, D. R.; Choi, G. B.; Huh, J. R., Maternal gut bacteria promote neurodevelopmental abnormalities in mouse offspring. *Nature* **2017**, 549, (7673), 528-532.
291. Buffington, S. A.; Di Prisco, G. V.; Auchtung, T. A.; Ajami, N. J.; Petrosino, J. F.; Costa-Mattioli, M., Microbial Reconstitution Reverses Maternal Diet-Induced Social and Synaptic Deficits in Offspring. *Cell* **2016**, 165, (7), 1762-1775.
292. Hsiao, E. Y.; McBride, S. W.; Hsien, S.; Sharon, G.; Hyde, E. R.; McCue, T.; Codelli, J. A.; Chow, J.; Reisman, S. E.; Petrosino, J. F.; Patterson, P. H.; Mazmanian, S. K., Microbiota modulate behavioral and physiological abnormalities associated with neurodevelopmental disorders. *Cell* **2013**, 155, (7), 1451-63.
293. Zhu, N.; Zhang, D.; Wang, W.; Li, X.; Yang, B.; Song, J.; Zhao, X.; Huang, B.; Shi, W.; Lu, R.; Niu, P.; Zhan, F.; Ma, X.; Wang, D.; Xu, W.; Wu, G.; Gao, G. F.; Tan, W.; China Novel Coronavirus, I.; Research, T., A Novel Coronavirus from Patients with Pneumonia in China, 2019. *N Engl J Med* **2020**, 382, (8), 727-733.
294. Kondratova, M.; Czerwinska, U.; Sompairac, N.; Amigorena, S. D.; Soumelis, V.; Barillot, E.; Zinovyev, A.; Kuperstein, I., A multiscale signalling network map of innate immune response in cancer reveals cell heterogeneity signatures. *Nat Commun* **2019**, 10, (1), 4808.
295. Ridker, P. M.; Rane, M., Interleukin-6 Signaling and Anti-Interleukin-6 Therapeutics in Cardiovascular Disease. *Circ Res* **2021**, 128, (11), 1728-1746.
296. Cable, J.; Heard, E.; Hirose, T.; Prasanth, K. V.; Chen, L. L.; Henninger, J. E.; Quinodoz, S. A.; Spector, D. L.; Diermeier, S. D.; Porman, A. M.; Kumar, D.; Feinberg, M. W.; Shen, X.; Unfried, J. P.; Johnson, R.; Chen, C. K.; Wilusz, J. E.; Lempradl, A.; McGeary, S. E.; Wahba, L.; Pyle, A. M.; Hargrove, A. E.; Simon, M. D.; Marcia, M.; Przanowska, R. K.; Chang, H. Y.; Jaffrey, S. R.; Contreras, L. M.; Chen, Q.; Shi, J.; Mendell, J. T.; He, L.; Song, E.; Rinn, J. L.; Lalwani, M. K.; Kalem, M. C.; Chuong, E. B.; Maquat, L. E.; Liu, X., Noncoding RNAs: biology and applications-a Keystone Symposia report. *Ann N Y Acad Sci* **2021**, 1506, (1), 118-141.

297. Roberts, L. B.; Kapoor, P.; Howard, J. K.; Shah, A. M.; Lord, G. M., An update on the roles of immune system-derived microRNAs in cardiovascular diseases. *Cardiovasc Res* **2021**, *117*, (12), 2434-2449.
298. Uchida, S.; Dimmeler, S., Long noncoding RNAs in cardiovascular diseases. *Circ Res* **2015**, *116*, (4), 737-50.
299. Lehmann, L. H.; Jebessa, Z. H.; Kreusser, M. M.; Horsch, A.; He, T.; Kronlage, M.; Dewenter, M.; Sramek, V.; Oehl, U.; Krebs-Haupenthal, J.; von der Lieth, A. H.; Schmidt, A.; Sun, Q.; Ritterhoff, J.; Finke, D.; Volkers, M.; Jungmann, A.; Sauer, S. W.; Thiel, C.; Nickel, A.; Kohlhaas, M.; Schafer, M.; Sticht, C.; Maack, C.; Gretz, N.; Wagner, M.; El-Armouche, A.; Maier, L. S.; Londono, J. E. C.; Meder, B.; Freichel, M.; Grone, H. J.; Most, P.; Muller, O. J.; Herzig, S.; Furlong, E. E. M.; Katus, H. A.; Backs, J., A proteolytic fragment of histone deacetylase 4 protects the heart from failure by regulating the hexosamine biosynthetic pathway. *Nat Med* **2018**, *24*, (1), 62-72.

Figure 1 (high resolution)

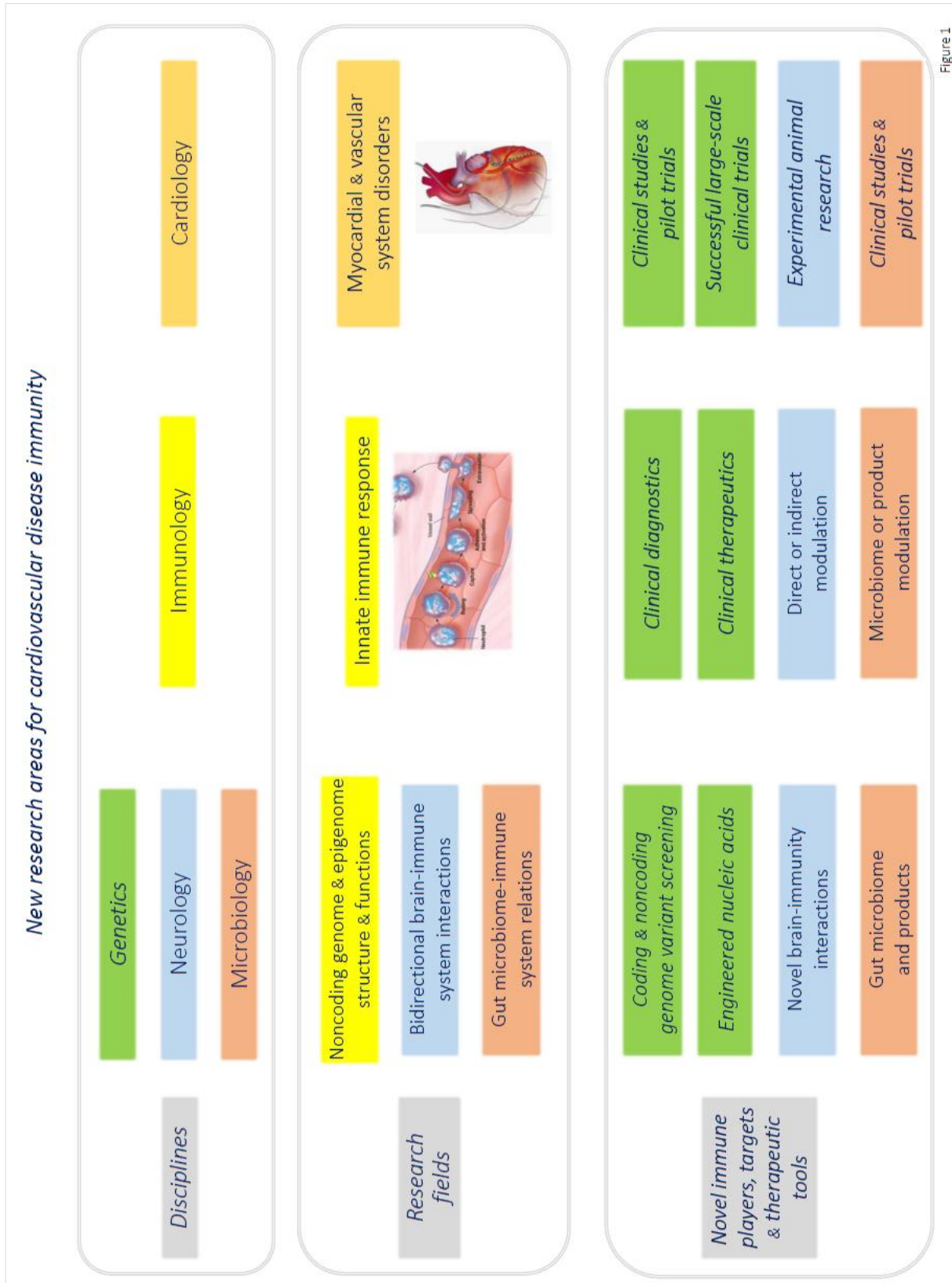

Figure 1

Figure 2 (high resolution)

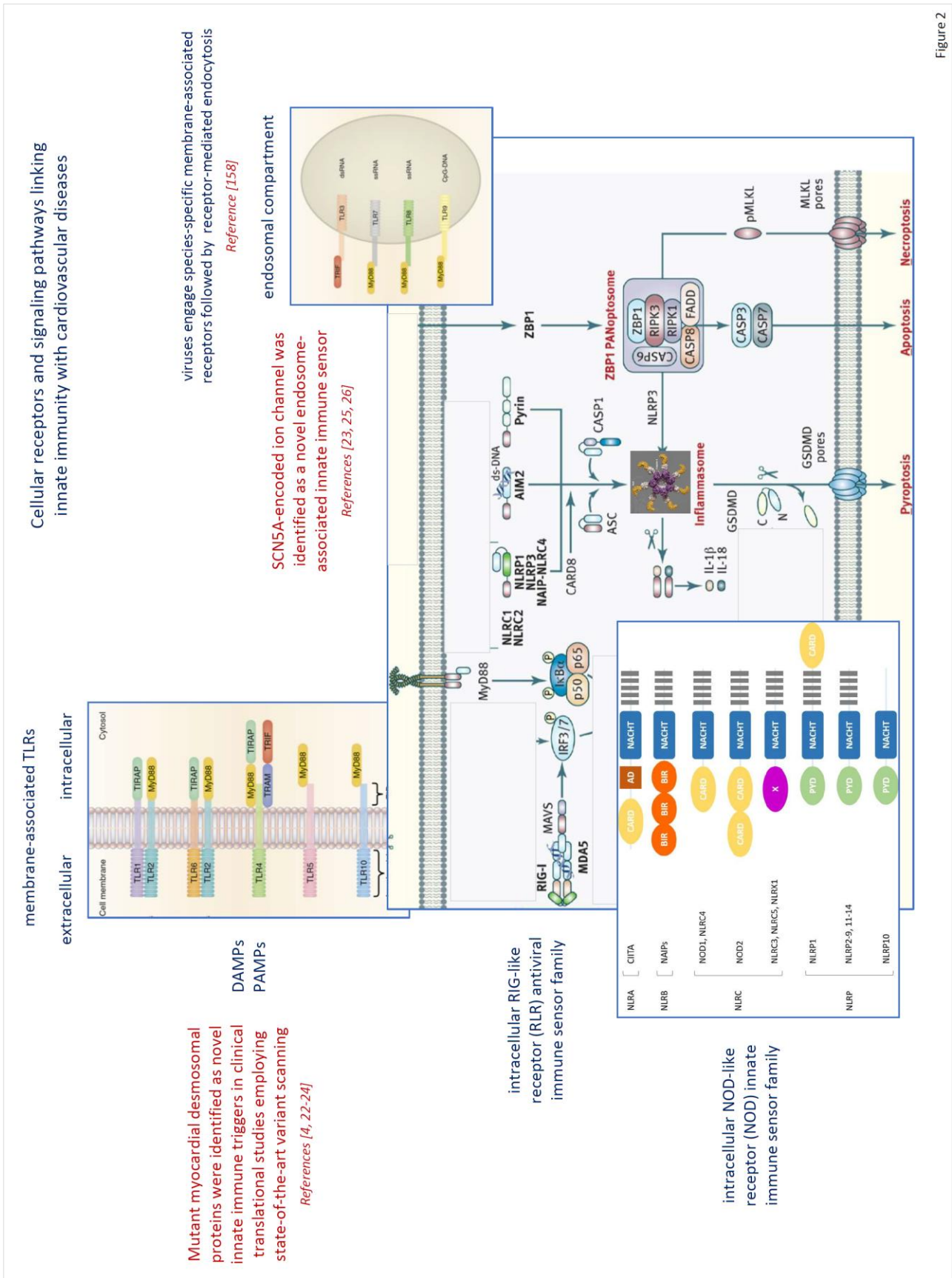

Figure 2



Figure 4 (high resolution)

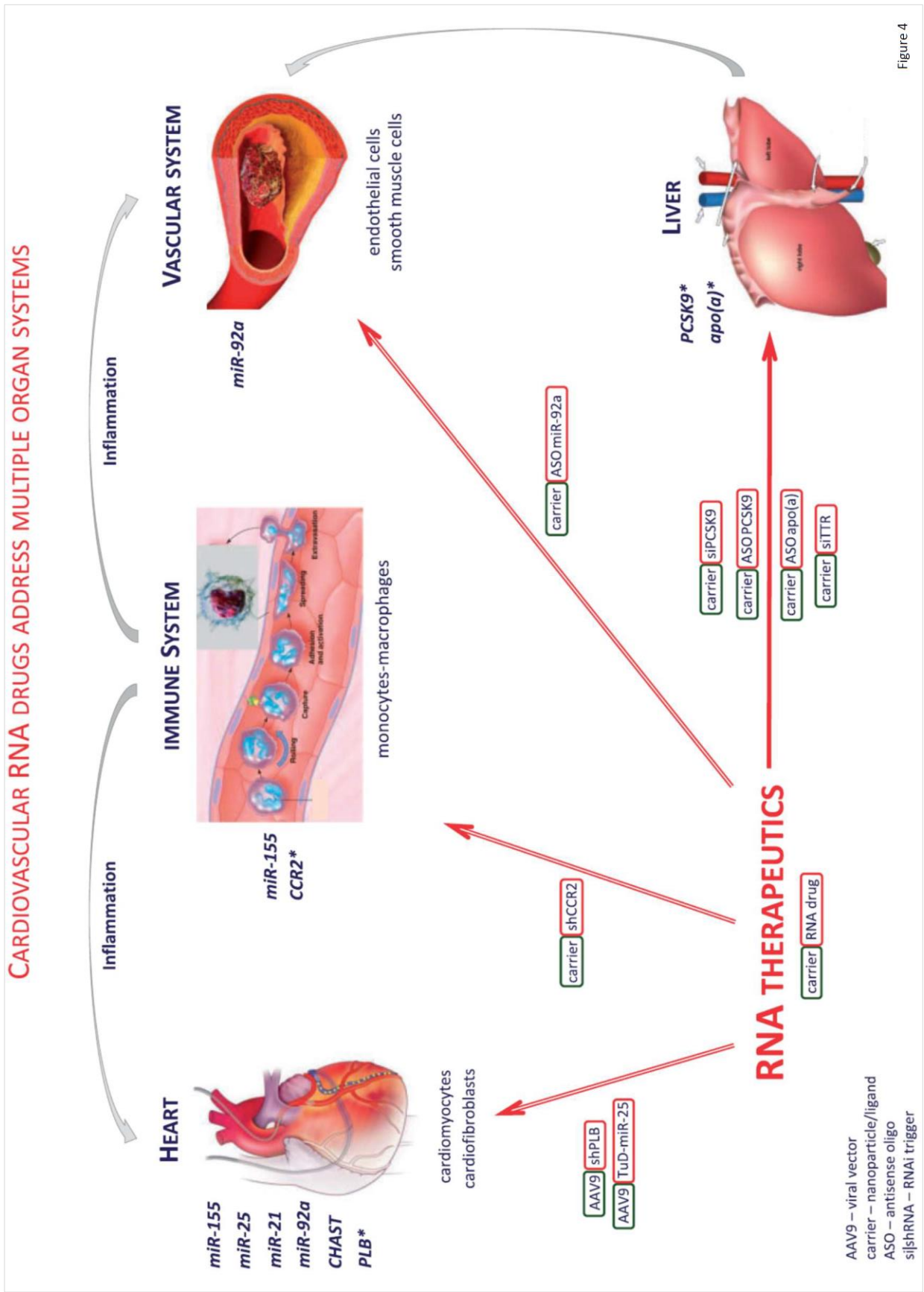

Figure 5 (high resolution)

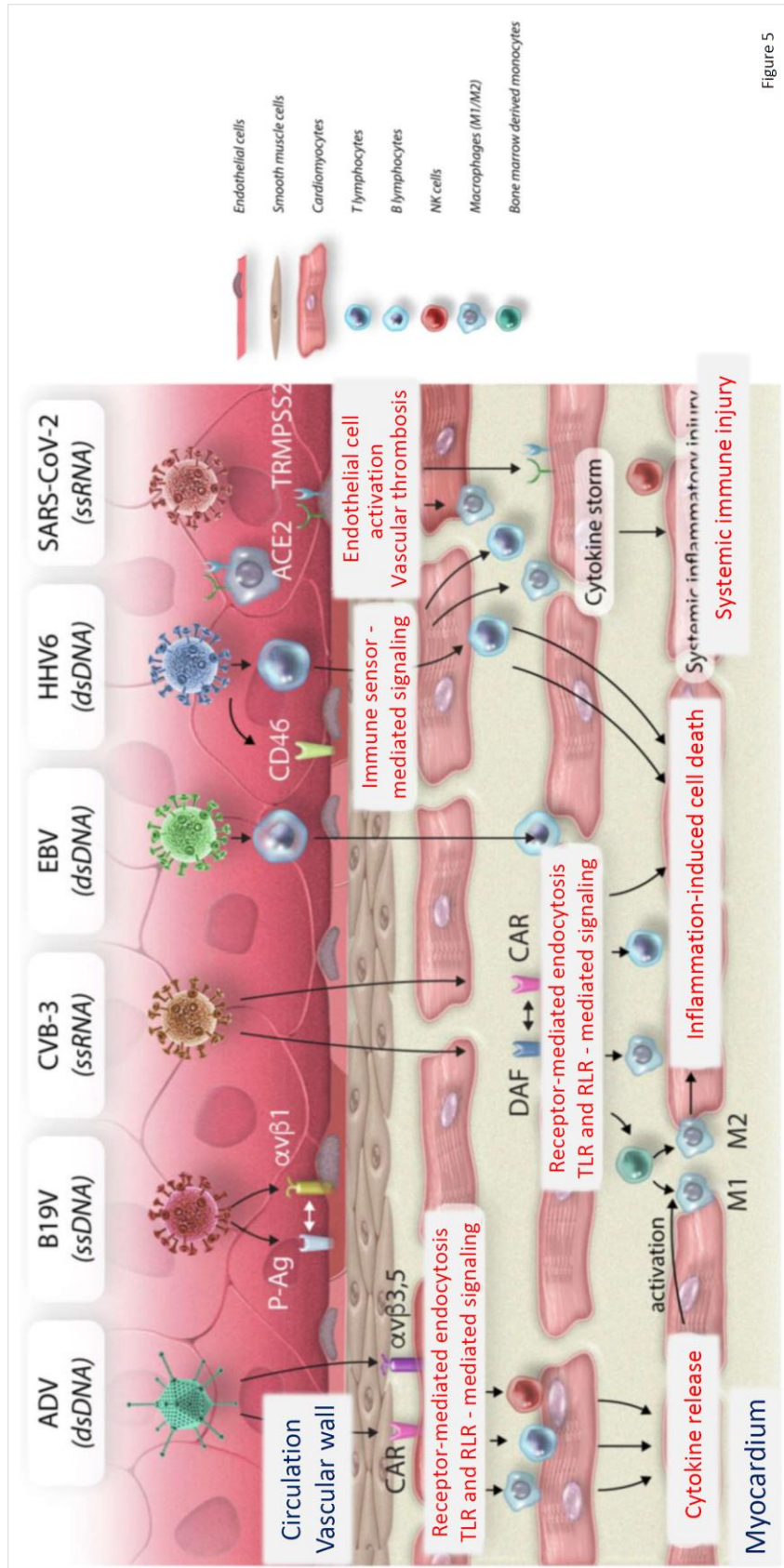

Figure 5

Figure 6 (high resolution)

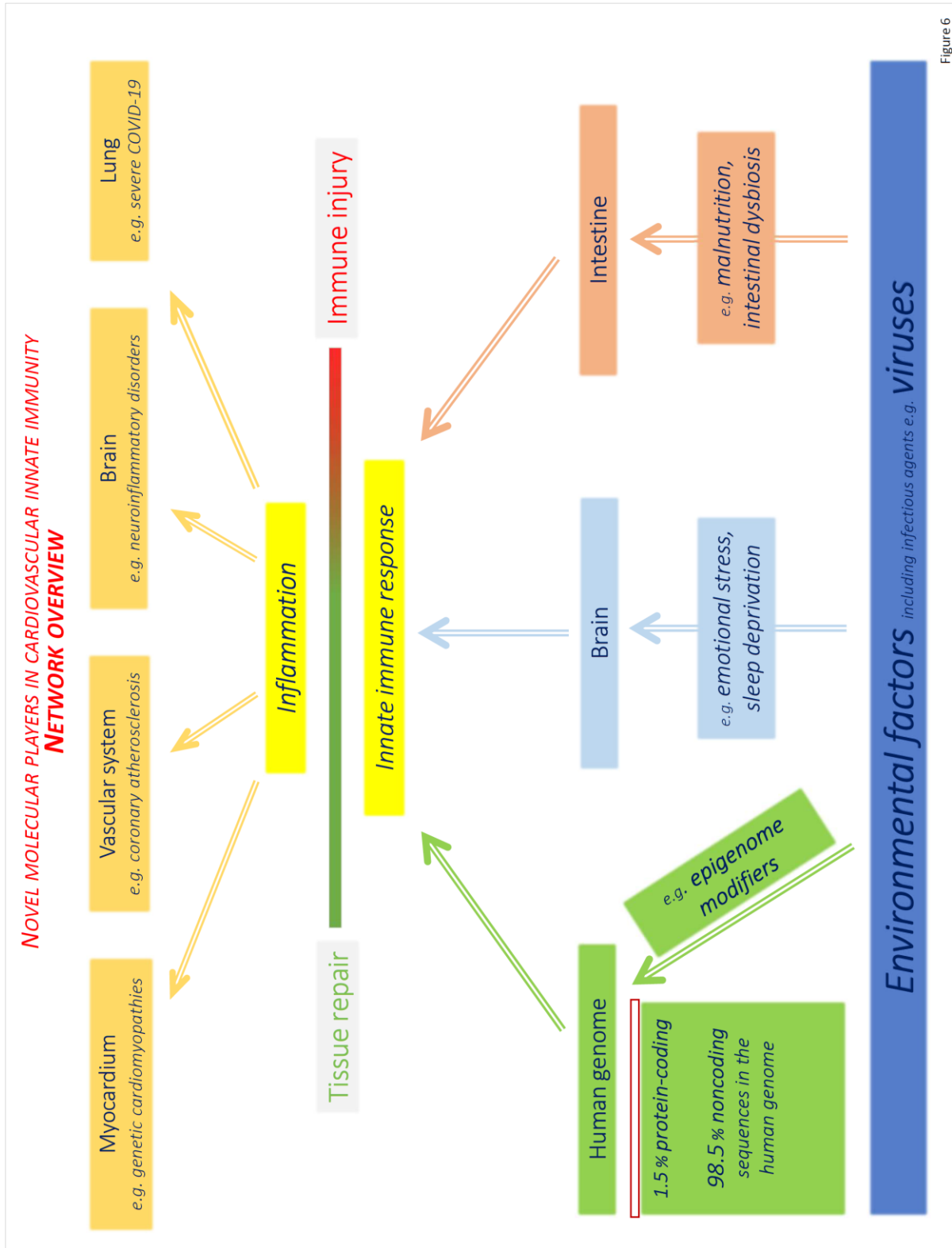

Figure 6

Figure 7 (high resolution)

